

DRIVER _____
 TRACK _____
 RACE _____ DATE _____
 TEMP _____ BEST LAP _____ BEST RESULT _____

TRACK SIZE TIGHT MEDIUM OPEN
 SURFACE DUSTY BLUE GROOVE LOW GRIP MEDIUM GRIP HIGH GRIP
 CONDITION SMOOTH BUMPY 50/50 CLAY GROOVE WITH DUST EGY
 QUALIFYING POS. _____ FINAL POS. _____

ENGINE _____	CLUTCH _____	FRONT DIFF OIL _____	OIL QUANTITY (gr) _____	DIFF GEAR _____
PLUG _____	CLUTCH SHOES _____	CENTER DIFF OIL _____	OIL QUANTITY (gr) _____	DIFF PINION _____
PIPE _____	CLUTCH SPRINGS _____	REAR DIFF OIL _____	OIL QUANTITY (gr) _____	SPUR GEAR _____
FUEL _____	RUNTIME _____			CLUTCH BELL _____

SHOCKS

	FRONT	REAR
OIL _____		
PISTON _____		
SPRING _____		
LENGTH _____		
VISIBLE SHAFT LENGTH _____		
REBOUND _____		
FRONT SHOCK END <input type="checkbox"/> LONG <input type="checkbox"/> SHORT		SHOCKS <input type="checkbox"/> EMULSION TYPE <input type="checkbox"/> BLADDER
NOTES		

FRONT END

SHOCK TOWER ALUMINIUM CARBON

HEX WIDTH 4 mm 5 mm 6 mm

KNUCKLE PLATE 1 LONG 2 SHORT

FRONT ARM POSITION FRONT MIDDLE REAR

ARM INSERT NO PLASTIC CARBON

KNUCKLE POSITION UP MIDDLE DOWN

KPI OPTION KPI 0 (ROUND MARK) KPI 1 (LONG MARK)

C BLOCK CASTER CASTER 1 (1 MARK) CASTER 2 (2 MARKS)

SERVO SAVER YES NO

BUMP STEER ON ACKERMAN UP DOWN SHIM _____ mm

BUMP STEER ON KNUCKLE UP DOWN SHIM _____ mm

KICK UP 1 0,5 0 0,5 1

A PLATE +2mm SHIM (NO upper gearbox shim) +2

B PLATE +1mm SHIM (1mm upper gearbox shim) +1

TOWER NO SHIM (2mm upper gearbox shim) 0

CHASSIS

	FRONT	REAR
CAMBER _____		
RIDE HEIGHT _____		
DOWNTRAVEL (WITH TYRES) _____		
DOWNTRAVEL (on 36mm blocks) _____		
ANTI ROLL BARS _____		
BRAKE BALANCE _____		
ENGINE MOUNT <input type="checkbox"/> FORWARD (+2mm) <input type="checkbox"/> SHORT <input type="checkbox"/> BACKWARD (-2mm) <input type="checkbox"/> LONG		
THROTTLE <input type="checkbox"/> SHORT <input type="checkbox"/> LONG		WEIGHT _____

TYRES

	FRONT	REAR
BRAND _____		
TREAD _____		
COMPOUND _____		
WHEELS _____		
INSERTS _____		
GLUED TO WHEEL <input type="checkbox"/> YES <input type="checkbox"/> NO		<input type="checkbox"/> YES <input type="checkbox"/> NO

REAR END

ARM INSERT NO PLASTIC CARBON

SHOCK TOWER ALUMINIUM CARBON

OPTIONAL REAR HUB 1,0 1,5 2,0 2,5 3,0 4,0 5,0 6,0

REAR HUB PLASTIC ALUMINIUM

HEX WIDTH 4 mm 5 mm 6 mm

SPACER IN FRONT OF HUB _____ mm

REAR AXLE CVD UNIVERSAL 91 94

ANTI-SQUAT 1 0,5 0 0,5 1

C PLATE +2mm SHIM +2

D PLATE +1mm SHIM +1

TOWER NO SHIM 0

TOE 3° 1,5° 0,5°

RADIO SETTINGS

	THROTTLE	STEERING
DUAL RATE _____		
SPEED _____		
EXPO _____		
SERVO MODEL _____		
THROTTLE _____		BRAKE _____
ELECTRIC EPA _____		

BODY & WING

BODYSHELL _____

WING BRAND _____

WING MODEL _____

WING POSITION 1 2 3 4
1 IS FRONT HOLE (WING BACK)

WING FLAPS BIG SMALL BOTH

GURNEY NO SMALL BIG

NOTES

FRONT END - UPPER ARMS

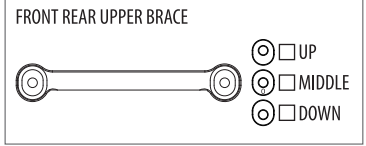
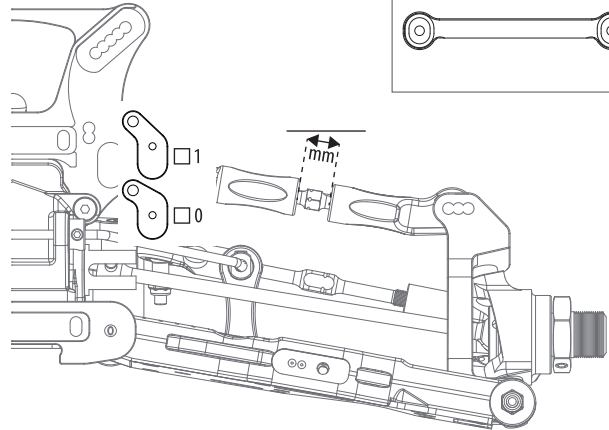
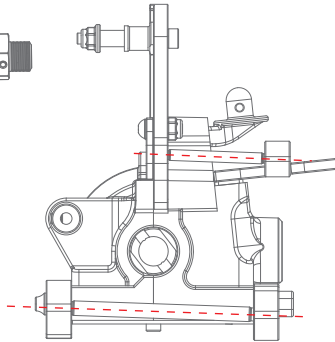
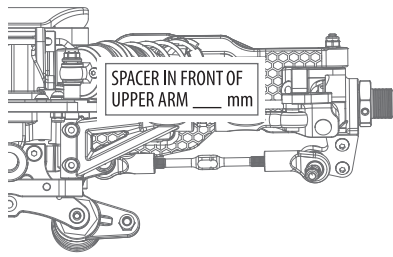

REAR END - UPPER ARMS

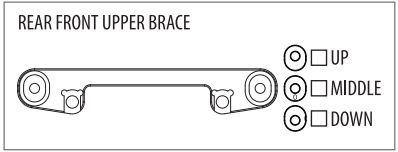
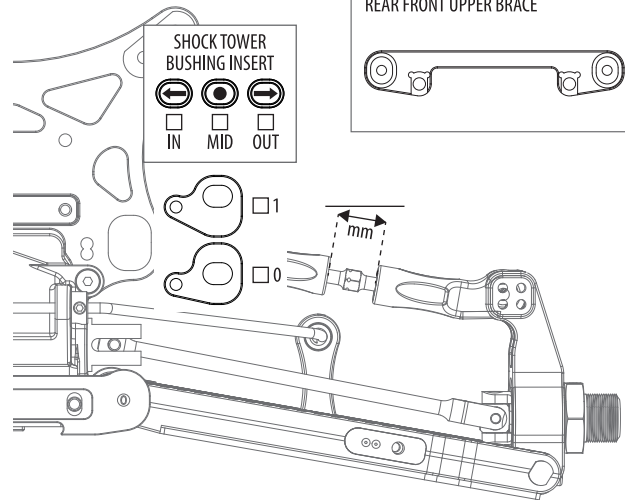
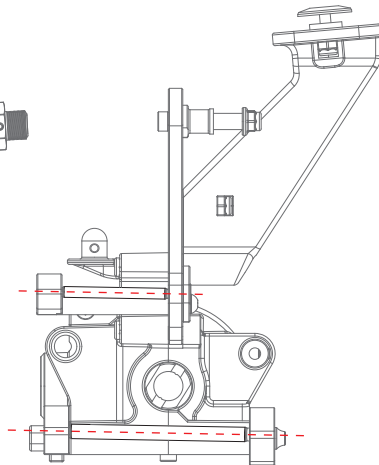
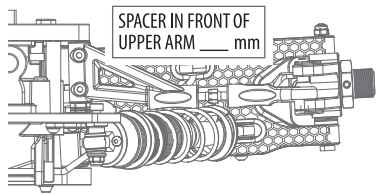

ADJUSTING UPPER ARMS

The upper arm angle is to be matched to the lower arm angle. There is a compromise for the upper arm, as a .5 change for the upper arm is so small.

The way to understand how to adjust the upper arm is as follows

1. When you have the same inserts, in the same direction in the front and rear blocks (A-B, or C-D), you should use the 0 insert for the upper arm.

Example:

When you run 0-0, .5 down - .5 down, or 1 up - 1 up in the A-B, or C-D blocks, those are all examples of running the same inserts and direction in both blocks. This means you should run the 0 (middle) insert for the upper arm.

2. When you have a 1mm difference between the inserts in the front and rear blocks (A-B, or C-D), you need to use the 1 (end) insert for the upper arm, in the same direction as the lower arm is angled, either larger or smaller angle.

Example:

When you run 0-1 down, 1 up - 0, or .5 up - .5 down, those are all examples of a 1mm difference and a larger angle.

You would need to run the 1 insert (end) down for the upper arm, making it a larger angle to match.

The opposite is true when you reduce the lower arm angle by a 1mm difference.

3. When you have a .5 difference between the inserts in the front and rear blocks (A-B, or C-D), you can chose to run either the 0 insert, or the 1 insert for the upper arm, matching the direction of the angle change of the lower arm.

Example:

When you run 0 - .5 up, .5 down - 0 or 1 down - .5 down, those are all examples of a .5mm difference and a smaller angle.

You would need to run the 0 insert, or 1 insert up for the upper arm. The opposite is true when you increase the lower arm angle by a .5mm difference.

The way to understand how to adjust the upper arm related to TOE IN is as follows

1.5° toe in: arrow inwards

3.0° toe in: arrow outwards