

SETUP SHEET
v. 1.0 - UPPER ARMS

DRIVER _____
 TRACK _____
 RACE _____ DATE _____
 TEMP _____ BEST LAP _____ BEST RESULT _____

TRACK SIZE TIGHT MEDIUM OPEN
 SURFACE DUSTY BLUE GROOVE LOW GRIP MEDIUM GRIP HIGH GRIP
 CONDITION SMOOTH BUMPY 50/50 CLAY GROOVE WITH DUST EGY
 QUALIFYING POS. _____ FINAL POS. _____

ENGINE _____ CLUTCH _____ FRONT DIFF OIL _____ OIL QUANTITY (gr) _____ DIFF GEAR _____
 PLUG _____ CLUTCH SHOES _____ CENTER DIFF OIL _____ OIL QUANTITY (gr) _____ DIFF PINION _____
 PIPE _____ CLUTCH SPRINGS _____ REAR DIFF OIL _____ OIL QUANTITY (gr) _____ SPUR GEAR _____
 FUEL _____ RUNTIME _____ CLUTCH BELL _____

SHOCKS

	FRONT	REAR
OIL	_____	_____
PISTON	_____	_____
SPRING	_____	_____
LENGTH	_____	_____
VISIBLE SHAFT LENGTH	_____	_____
REBOUND	_____	_____
FRONT SHOCK END <input type="checkbox"/> LONG <input type="checkbox"/> SHORT		SHOCKS <input type="checkbox"/> EMULSION TYPE <input type="checkbox"/> BLADDER
NOTES	_____	

FRONT END

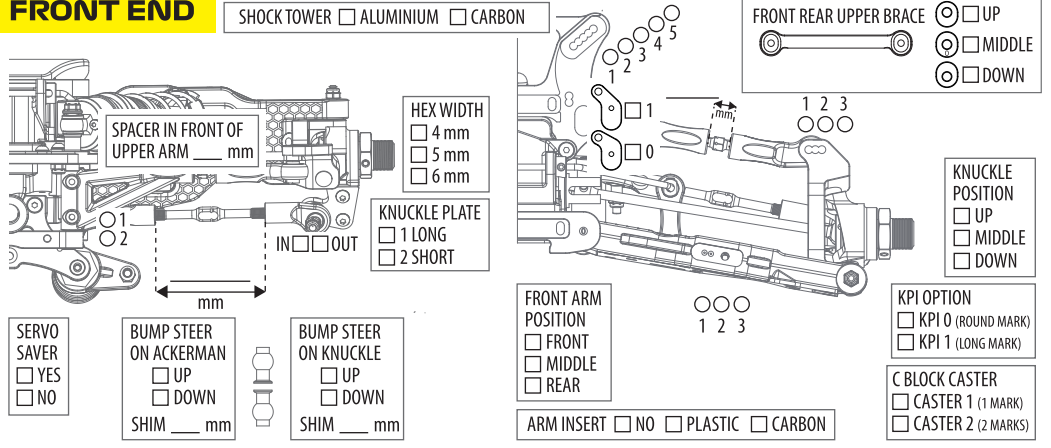

KICK UP

	A PLATE	B PLATE	TOWER
1	<input type="checkbox"/>	<input type="checkbox"/>	<input type="checkbox"/>
0,5	<input type="checkbox"/>	<input type="checkbox"/>	<input type="checkbox"/>
0	<input type="checkbox"/>	<input type="checkbox"/>	<input type="checkbox"/>
0,5	<input type="checkbox"/>	<input type="checkbox"/>	<input type="checkbox"/>
1	<input type="checkbox"/>	<input type="checkbox"/>	<input type="checkbox"/>

+2mm SHIM (NO upper gearbox shim)

+1mm SHIM (1mm upper gearbox shim)

NO SHIM (2mm upper gearbox shim)

CHASSIS

	FRONT	REAR
CAMBER	_____	_____
RIDE HEIGHT	_____	_____
DOWNTRAVEL (WITH TYRES)	_____	_____
DOWNTRAVEL (on 36mm blocks)	_____	_____
ANTI ROLL BARS	_____	_____
BRAKE BALANCE	_____	_____
ENGINE MOUNT <input type="checkbox"/> FORWARD (+2mm) <input type="checkbox"/> SHORT <input type="checkbox"/> BACKWARD (-2mm) <input type="checkbox"/> LONG		
THROTTLE <input type="checkbox"/> SHORT <input type="checkbox"/> LONG		
SERVO MOUNT <input type="checkbox"/> LONG		WEIGHT _____

REAR END

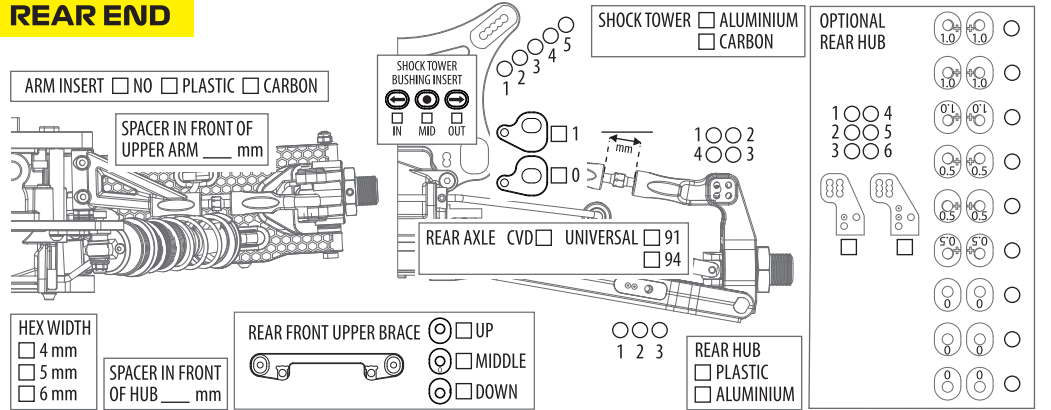

ANTI-SQUAT

	C PLATE	D PLATE	TOWER
1	<input type="checkbox"/>	<input type="checkbox"/>	<input type="checkbox"/>
0,5	<input type="checkbox"/>	<input type="checkbox"/>	<input type="checkbox"/>
0	<input type="checkbox"/>	<input type="checkbox"/>	<input type="checkbox"/>
0,5	<input type="checkbox"/>	<input type="checkbox"/>	<input type="checkbox"/>
1	<input type="checkbox"/>	<input type="checkbox"/>	<input type="checkbox"/>

+2mm SHIM

+1mm SHIM

NO SHIM

TYRES

	FRONT	REAR
BRAND	_____	_____
TREAD	_____	_____
COMPOUND	_____	_____
WHEELS	_____	_____
INSERTS	_____	_____
GLUED TO WHEEL <input type="checkbox"/> YES <input type="checkbox"/> NO		<input type="checkbox"/> YES <input type="checkbox"/> NO

RADIO SETTINGS

	THROTTLE	STEERING
DUAL RATE	_____	_____
SPEED	_____	_____
EXPO	_____	_____
SERVO MODEL	_____	_____
	THROTTLE	BRAKE
ELECTRIC EPA	_____	_____

BODY & WING

BODYSHELL _____

WING BRAND _____

WING MODEL _____

WING POSITION 1 2 3 4
1 IS FRONT HOLE (WING BACK)

WING FLAPS BIG SMALL BOTH

GURNEY NO SMALL BIG

NOTES
