

Name: _____	Date: _____ Event: _____
City: _____ State: _____	Track: _____

Track Conditions	<input type="checkbox"/> Indoor	<input type="checkbox"/> Tight	<input type="checkbox"/> Smooth	<input type="checkbox"/> Hard Packed	<input type="checkbox"/> Blue Groove	<input type="checkbox"/> Wet	<input type="checkbox"/> Grass	<input type="checkbox"/> Low Bite	<input type="checkbox"/> High Bite
	<input type="checkbox"/> Outdoor	<input type="checkbox"/> Open	<input type="checkbox"/> Rough	<input type="checkbox"/> Loose/Loamy	<input type="checkbox"/> Dry	<input type="checkbox"/> Dusty	<input type="checkbox"/> Astro Turf	<input type="checkbox"/> Med Bite	<input type="checkbox"/> Other _____

Front Suspension

Toe: _____

Ride Height: _____

Camber: _____

Caster: 10° 15° 20°

Sway Bar: _____

Oil: _____

Piston: _____

Spring: Standard Low Freq. Color: _____

Shock Limiters: _____

Shock Location: _____

Bump Steer Ball Stud: Standard Low Mount

Bumper Steer Spacers: _____

Camber Link: _____

Ackermann: _____

Notes: _____

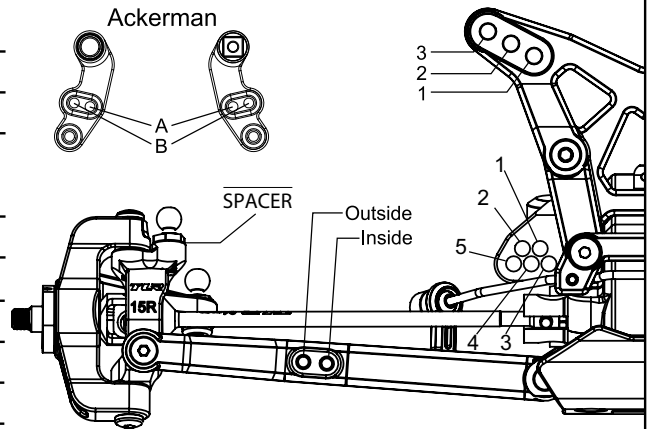

- TLR331012 Aluminum Servo Mount
- TLR334007 Aluminum Front Spindle
- TLR334009 Aluminum Steering Bellcrank

Rear Suspension

Toe: _____

Anti-Squat: _____

Roll Center: Low Roll Center (LRC) High Roll Center (HRC)

Ride Height: _____

Camber: _____

Rear Hub Spacing: _____

Hex Width: _____

Sway Bar: _____

Oil: _____

Piston: _____

Spring: Standard Low Freq. Color: _____

Shock Limiters: _____

Camber Link: _____

Shock Locations: _____

Wing/Wickerbill: _____

Battery Position: _____

Notes: _____

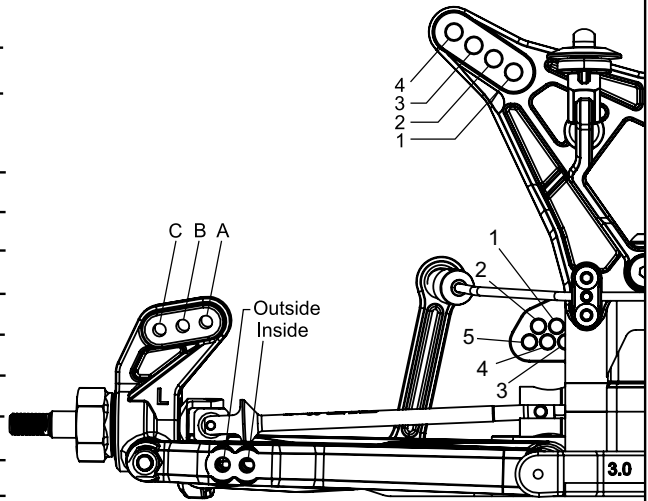

- TLR334008 Aluminum Rear Hub

Electronics

Radio: _____	Timing Advance: _____
Servo: _____	Throttle/Brake Expo: _____
ESC: _____	Servo Expo: _____
Initial Brake: _____	Throttle/Brake EPA: _____
Drag Brake: _____	Motor: _____
Throttle Profile: _____	Pinion: _____ Spur: _____
	Battery: _____

Tires

	Compound	Insert	Additive
Front: _____	_____	_____	_____
Rear: _____	_____	_____	_____
Notes: _____			