

# TENLOS SETUP SHEET XXX-CR

Name: Tomas Gonzalez

Date: 11/20/2006

Event: Ashtabula Indoor

City: \_\_\_\_\_ State: \_\_\_\_\_

Track: \_\_\_\_\_

Track  Indoor  Tight  Smooth  Hard Packed  Blue Groove  Wet  Low Bite  High Bite  
 Conditions  Outdoor  Open  Rough  Loose/Loamy  Dry  Dusty  Med Bite  Other \_\_\_\_\_

## Front Suspension

Toe: 0.5° Toe-In  
 Ride Height: Leveld Drive shafts  
 Camber: -1°  
 Caster: 30° (stock)  
 Sway Bar: no  
 Oil: 35  
 Piston: 543 (drilled)  
 Spring: silver  
 Limiters: .060  
 Spindle Height: bottom  
 Axle Spacer: narrow  
 Steering Type: \_\_\_\_\_  
 Bump Steer: 0  
 Camber Link: 2A/1  
 Shock Location: 2-middle  
 VLA: short  
 Front Wing: none

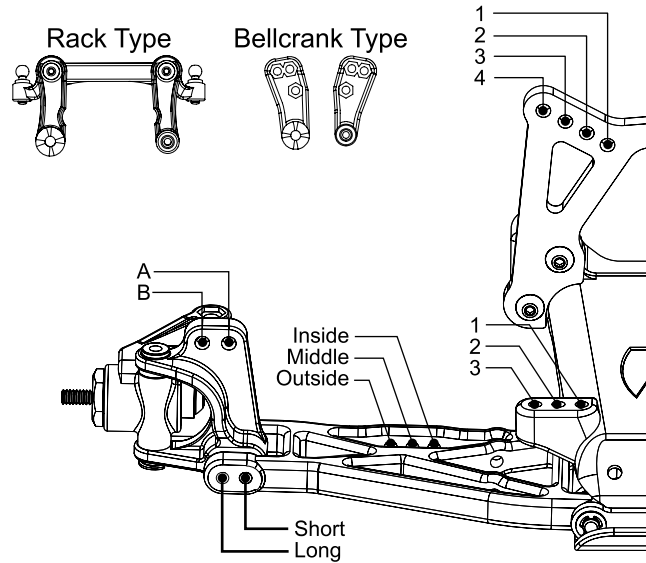

Notes: \_\_\_\_\_  
 \_\_\_\_\_  
 \_\_\_\_\_

## Rear Suspension

Toe: 3° Block, 0.5° Hubs  
 Pivot Support: 0° Pivot, 1 Shims (1° total)  
 Ride Height: Leveled Drive shafts  
 Camber: -1°  
 Rear Hub Spacing: middle  
 Drive Shafts/Outdrives: aluminum CVD's/steel outdrives  
 Sway Bar: no  
 Oil: 37.5  
 Piston: 553 (drilled)  
 Spring: red  
 Limiters: .090  
 Camber Link: 2B/3  
 Shock Location: 2-middle  
 VLA: short  
 Wing Position/Mount: Forward/Bottom  
 Body & Wing Type: XXX-CR/XXX-CR (Single Wing)  
 Battery Position: Forward

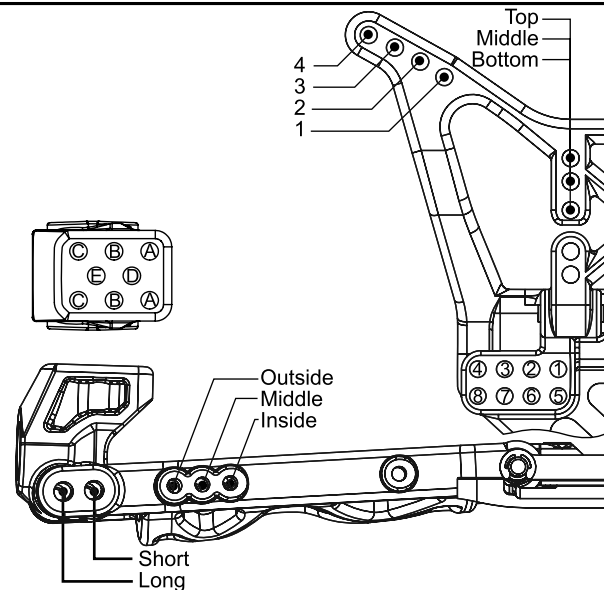

Notes: \_\_\_\_\_  
 \_\_\_\_\_  
 \_\_\_\_\_

Weight Placement  
(Mark with "X")

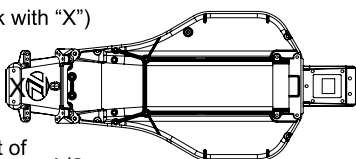

Weight of each piece 1/2 oz.

Tires: Type \_\_\_\_\_ Compound \_\_\_\_\_ Insert \_\_\_\_\_ Additive \_\_\_\_\_ Motor: \_\_\_\_\_  
 Front: Directional Soft \_\_\_\_\_ Pink \_\_\_\_\_ Simple green Spur: 78  
 Rear: X-2000 Pink \_\_\_\_\_ PINK \_\_\_\_\_ \_\_\_\_\_ Pinon: 22

Notes: \_\_\_\_\_  
 \_\_\_\_\_