



# Setup Sheet

Driver: Brian Kinwald

Date: \_\_\_\_\_

Track: 2003 IFMAR Worlds

<input type="checkbox"/> Indoor	<input checked="" type="checkbox"/> Smooth	<input checked="" type="checkbox"/> Slippery
<input checked="" type="checkbox"/> Outdoor	<input type="checkbox"/> Rough	<input type="checkbox"/> High-Bite
<input type="checkbox"/> Tight / <input checked="" type="checkbox"/> Open		<input type="checkbox"/> Blue-Groove

## FRONT SUSPENSION *(Circle or Check the Appropriate Settings)*

Toe  In 1 °  
 Out \_\_\_\_\_ °

Ride Height Arms Level

Camber  - 1/2 °  
 + \_\_\_\_\_ °

Caster  Stock \_\_\_\_\_ °  
 Other \_\_\_\_\_ °

Sway Bar  No  
 Yes size: \_\_\_\_\_

# of washers under steering/tie-rod ball studs  
Spindle ball stud: 0  
Bellcrank ball stud: 0

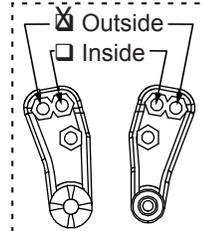

# of washers under ball stud: 1

Spindle Location

A  
 B  
 Middle  
 Bottom

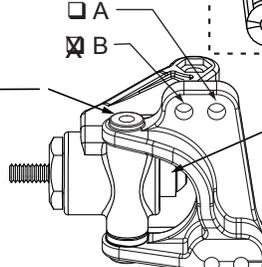

Axle Spacer

Narrow - inside  
 Wide - outside

Inside  
 Middle  
 Outside

1  
 2  
 3

Long  
 Short

Long  
 Short

### Front Shocks

Oil: 27

Piston:  56  Standard /  Drilled

Spring: Silver Internal:  Yes /  No

Limiters:  Inside-.060  Outside-0

## REAR SUSPENSION

Toe-In  Inside 3 °  
 Outside 1 °

Pivot Support  No Shim  
 Shim Under Front — # of shims: \_\_\_\_\_

Ride Height Bones below level - chassis level with front

Camber  - 1/2 °  
 + \_\_\_\_\_ °

Rear Hub Spacing  Forward  
 Center  
 Rear

Sway Bar  No  
 Yes size: \_\_\_\_\_

Body: Stock

Wing: Stock

Front Wing:  Yes /  No

Wing Position

Forward  
 Back

Wing Mount

Top  
 Bottom

4  
 3  
 2  
 1

Drive Shafts  Dogbones  Aluminum  
 CVDs  Steel

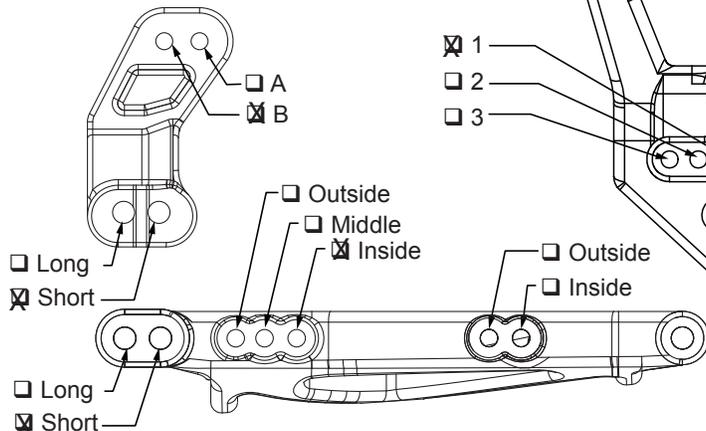

### Rear Shocks

Oil: 27

Piston:  56  Standard /  Drilled

Spring: Red Internal:  Yes /  No

Limiters:  Inside-.090  Outside-\_\_\_\_\_

## Tires

Front: BK 3 Rib

Rear: \_\_\_\_\_

Compound Red

Foam Losi Firm

Motor: 13x2 Pinion/Spur:  22/78

Battery Position: Forward

Weather Conditions/Notes: \_\_\_\_\_