

| | | | | | |
|------------------|----------------------------------|-------------------------------------|-----------------------------------|--------------------------------------|--------------------------------------|
| Name: _____ | | Date: _____ | | Event: _____ | |
| City: _____ | | State: _____ | | Track: _____ | |
| Track Conditions | <input type="checkbox"/> Indoor | <input type="checkbox"/> Tight | <input type="checkbox"/> Smooth | <input type="checkbox"/> Hard Packed | <input type="checkbox"/> Blue Groove |
| | <input type="checkbox"/> Outdoor | <input type="checkbox"/> Open | <input type="checkbox"/> Rough | <input type="checkbox"/> Loose/Loamy | <input type="checkbox"/> Dry |
| | <input type="checkbox"/> Wet | <input type="checkbox"/> Grass | <input type="checkbox"/> Low Bite | <input type="checkbox"/> High Bite | |
| | <input type="checkbox"/> Dusty | <input type="checkbox"/> Astro Turf | <input type="checkbox"/> Med Bite | <input type="checkbox"/> Other _____ | |

Front Suspension

Toe: _____

Ride Height: _____

Camber: _____

Steering Ackerman: _____

Sway Bar: _____

Shock Type: Bladder Emulsion Oil: _____

Piston: _____

Spring: _____

Limiters/Droop: _____

Overall Shock Length: _____

Shock Location: _____

Bump Steer: _____

Camber Link: _____

Front Diff Fluid: _____

Center Diff Fluid: _____

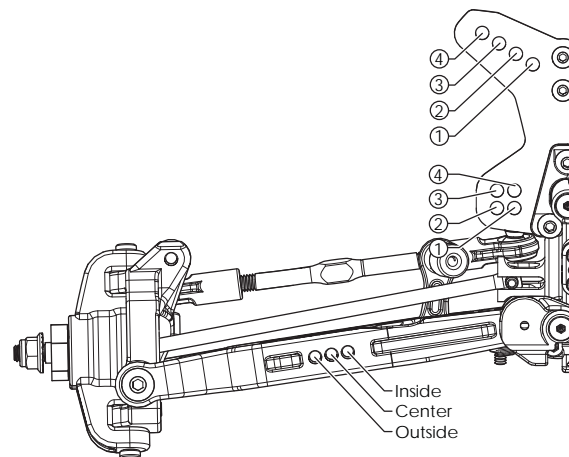

Notes: _____

Rear Suspension

Toe: _____

Anti-Squat: _____

Ride Height: _____

Camber: _____

Rear Hub Spacing: _____

Sway Bar: _____

Shock Type: Bladder Emulsion Oil: _____

Piston: _____

Spring: _____

Limiters/Droop: _____

Camber Link: _____

Shock Locations: _____

Overall Shock Length: _____

Rear Diff Fluid: _____

Battery Position: _____

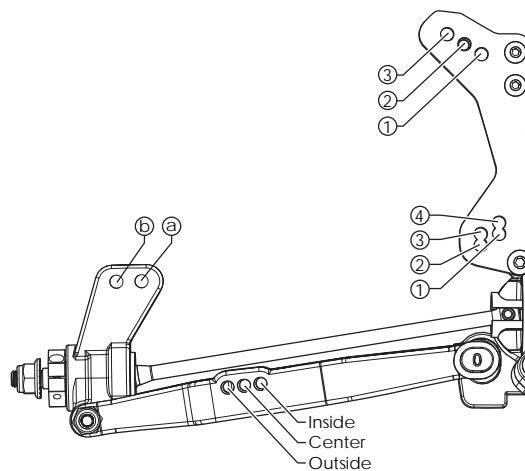

Electronics

| | |
|-------------------------|----------------------------|
| Radio: _____ | Timing Advance: _____ |
| Servo: _____ | Throttle/Brake Expo: _____ |
| ESC: _____ | Servo Expo: _____ |
| Initial Brake: _____ | Throttle/Brake EPA: _____ |
| Drag Brake: _____ | Motor: _____ |
| Throttle Profile: _____ | Pinion: _____ Spur: _____ |
| | Battery: _____ |

Weight Placement
(Mark with "X")

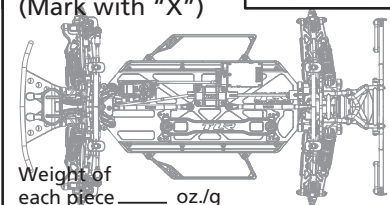

Weight of each piece _____ oz./g

| | Compound | Insert | Additive |
|--------------------|----------|--------|----------|
| Tires Front: _____ | _____ | _____ | _____ |
| Tires Rear: _____ | _____ | _____ | _____ |
| Notes: _____ | _____ | | |