

Name: Musso Thomas		Date: _____	Event: GP ARCF42
City: _____		State: France	
Track		Track: ARCF42	
Conditions: <input type="checkbox"/> Indoor <input type="checkbox"/> Tight <input type="checkbox"/> Smooth <input type="checkbox"/> Hard Packed <input checked="" type="checkbox"/> Blue Groove <input type="checkbox"/> Wet <input checked="" type="checkbox"/> Low Bite <input type="checkbox"/> High Bite <input checked="" type="checkbox"/> Outdoor <input type="checkbox"/> Open <input type="checkbox"/> Rough <input type="checkbox"/> Loose/Loamy <input type="checkbox"/> Dry <input type="checkbox"/> Dusty <input type="checkbox"/> Med Bite <input checked="" type="checkbox"/> Other _____			

**Front Suspension**

Toe: -2 degrees \_\_\_\_\_  
 Ride Height: 24mm \_\_\_\_\_  
 Camber: 2 degrees \_\_\_\_\_  
 Caster: Stock \_\_\_\_\_  
 Spindle Height:  High  Low \_\_\_\_\_  
 Wheel Hex: Stock \_\_\_\_\_  
 Sway Bar: 2.3mm \_\_\_\_\_  
 Piston/Oil: 5x1.5 37Wt \_\_\_\_\_  
 Shock Type:  Bladder  Emulsion \_\_\_\_\_  
 Spring: Green \_\_\_\_\_  
 Limiter/Droop: Max \_\_\_\_\_  
 Overall Shock Length: \_\_\_\_\_  
 Steering Ackerman: Short \_\_\_\_\_  
 Bump Steer: Down \_\_\_\_\_  
 Camber Link: 2 \_\_\_\_\_  
 Shock Location: 3-Inside \_\_\_\_\_  
 Battery Location:  Forward  Aft \_\_\_\_\_

**Differentials**

Front:  Standard  Smart \_\_\_\_\_  
 Spring Wire Dia.: \_\_\_\_\_  
 Qty of Springs: \_\_\_\_\_  
 Ramp Plate: \_\_\_\_\_  
 Grease: \_\_\_\_\_  
 Diff Fluid: 5 000 \_\_\_\_\_  
 Center:  Standard  Smart \_\_\_\_\_  
 Location: \_\_\_\_\_  
 0-Degree  4.4-Degree \_\_\_\_\_  
 Spring Wire Dia.: \_\_\_\_\_  
 Qty of Springs: \_\_\_\_\_  
 Ramp Plate: \_\_\_\_\_  
 Grease: \_\_\_\_\_  
 Diff Fluid: 5 000 \_\_\_\_\_

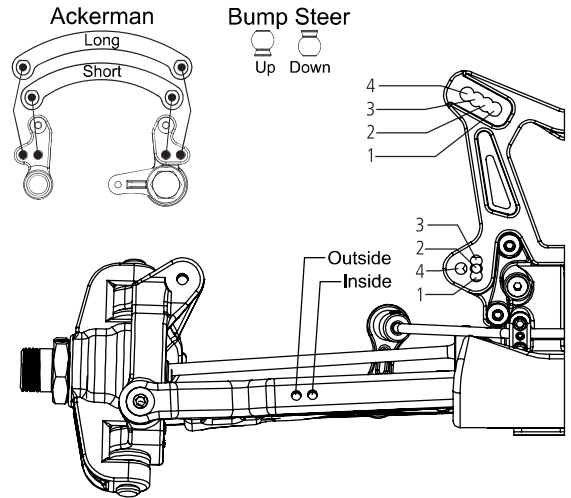

Notes: inserts 0 on both toe blocks  
 \_\_\_\_\_  
 \_\_\_\_\_

**Rear Suspension**

Roll Center:  HRC  LRC \_\_\_\_\_  
 Toe: 2.5 degrees \_\_\_\_\_  
 Anti-Squat: 1 degrees (bushing 1 down) \_\_\_\_\_  
 Ride Height: 26mm \_\_\_\_\_  
 Camber: -2 degrees \_\_\_\_\_  
 Rear Hub Spacing: \_\_\_\_\_  
 Wheel Hex: +1 stock \_\_\_\_\_  
 Sway Bar: 2.3mm \_\_\_\_\_  
 Piston/Oil: 5x1.6 37Wt \_\_\_\_\_  
 Shock Type:  Bladder  Emulsion \_\_\_\_\_  
 Spring: Silver \_\_\_\_\_  
 Limiter/Droop: Max \_\_\_\_\_  
 Overall Shock Length: \_\_\_\_\_  
 Camber Link: B-2 \_\_\_\_\_  
 Shock Position: 3-Inside \_\_\_\_\_  
 Rear Diff Fluid: 3 000 \_\_\_\_\_

**Wing Setup**

Wing Type:  2.0  3.0 \_\_\_\_\_  
 Wing Spacer:  .250  .500 \_\_\_\_\_  
 Wicker Bill:  .250  .350 \_\_\_\_\_

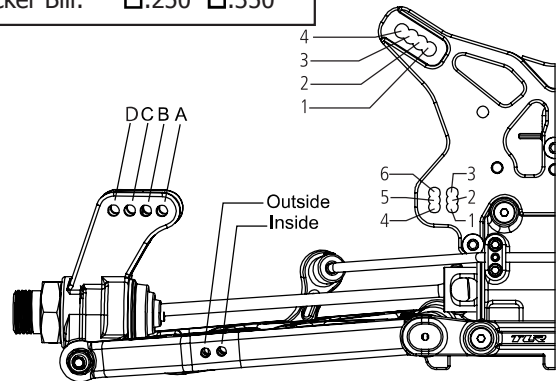

Notes: advance the plastic wing more 9mm in front  
 Option weight rear  
 \_\_\_\_\_  
 \_\_\_\_\_

**Electronics**

Radio: Spektrum DX4R \_\_\_\_\_  
 Servo: Spektrum s6260 \_\_\_\_\_  
 ESC: Reds \_\_\_\_\_  
 Initial Brake: \_\_\_\_\_  
 Drag Brake: \_\_\_\_\_  
 Throttle Profile: Linear \_\_\_\_\_  
 Timing Advance: 4 \_\_\_\_\_  
 Throttle/Brake Expo: \_\_\_\_\_  
 Throttle/Brake EPA: 100% \_\_\_\_\_  
 Servo Expo: \_\_\_\_\_  
 Motor: Reds v8 2100Kv \_\_\_\_\_  
 Pinion: 14 \_\_\_\_\_  
 Spur: 45 \_\_\_\_\_  
 Battery: On power Lipo 6500 \_\_\_\_\_

**Clutch**

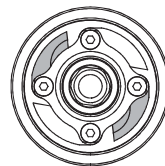

**Clutch Shoes and Springs Info**

No clutch  
 \_\_\_\_\_  
 \_\_\_\_\_

**Tires**

	Type	Compound	Insert
Front:	Rapid	CS	6mik
Rear:	Rapid	CS	6mik
Notes:	_____		
	_____		