

NAME: _____ DATE: _____ EVENT: _____ TRACK: _____

TRACK CONDITIONS

Indoor Clay Carpet Tight Smooth Hard Packed Blue Groove Wet Bite: Low Med High
 Outdoor Dirt Astro Open Rough Loose/Loamy Dry Dusty Tread: Pin Ghost Slick

FRONT SUSPENSION

Ride Height	mm
Camber	°
Toe	°
Sway Bar	mm
Notes	

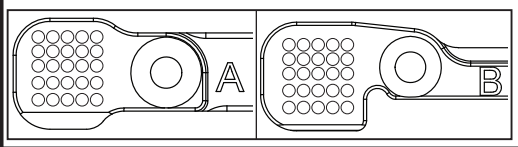
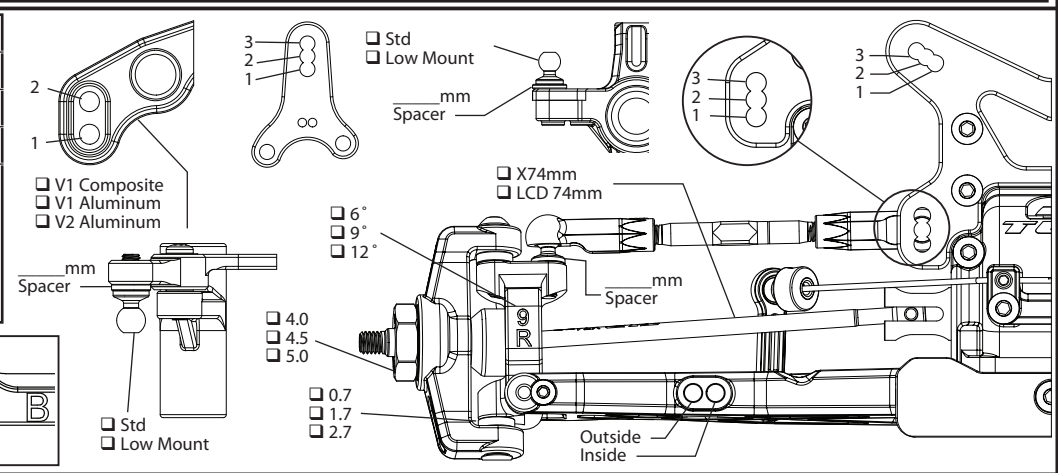

REAR SUSPENSION

Ride Height	mm
Camber	°
Sway Bar	mm
Notes	

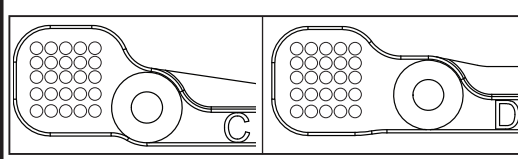
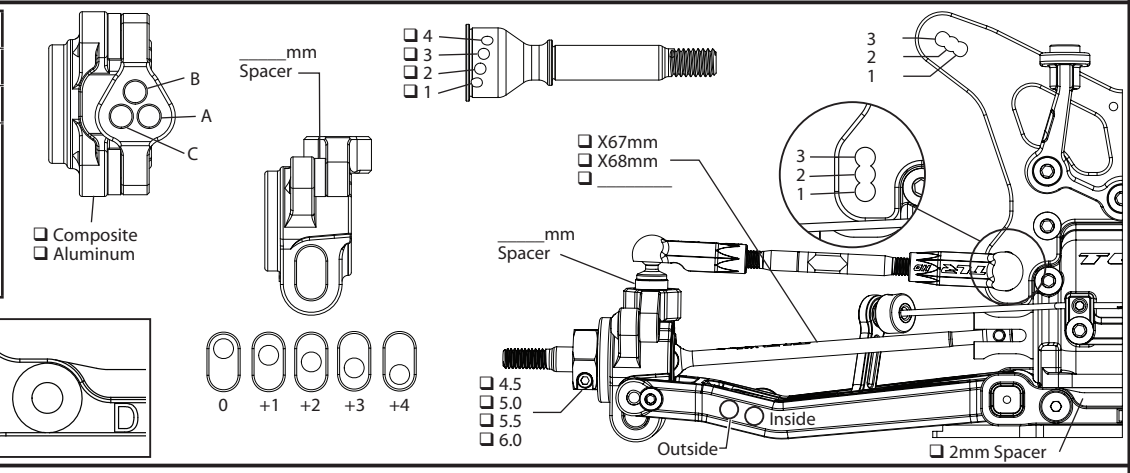

CHASSIS

	Front	Center	Rear
Fluid			
Int Gears	<input type="checkbox"/> Stl <input type="checkbox"/> Comp	<input type="checkbox"/> Stl <input type="checkbox"/> Comp	<input type="checkbox"/> Stl <input type="checkbox"/> Comp
Weight	g	g	g
Ring/Pin	<input type="checkbox"/> Stl <input type="checkbox"/> Comp	<input type="checkbox"/> Stl <input type="checkbox"/> Comp	<input type="checkbox"/> Stl <input type="checkbox"/> Comp
Center Diff Cover	<input type="checkbox"/> Composite	<input type="checkbox"/> Aluminum	
Slipper Pads	<input type="checkbox"/> Torque/Yellow		<input type="checkbox"/> Drive/Orange

AERODYNAMICS

Body	
Fr Scoop	
Rr Wing	
Wicker	
Angle	°
Notes	

TIRES

	Front	Rear
Tyre		
Compound		
Insert		
Sauce		
Wheel		
Notes		

SHOCKS

	Front	Rear
Shock Caps		
Oil		
Piston	<input type="checkbox"/> Thin	<input type="checkbox"/> Thin
Limiters, Int	mm	mm
Shaft Dia	<input type="checkbox"/> 3.0mm <input type="checkbox"/> 3.5mm	<input type="checkbox"/> 3.0mm <input type="checkbox"/> 3.5mm
Limiters, Ext	mm	mm
Stroke	mm	mm
Eyelet	<input type="checkbox"/> Std <input type="checkbox"/> +2mm	<input type="checkbox"/> Std <input type="checkbox"/> +2mm
Spring		
Spring Cup	<input type="checkbox"/> Low <input type="checkbox"/> Mid <input type="checkbox"/> High	<input type="checkbox"/> Low <input type="checkbox"/> Mid <input type="checkbox"/> High

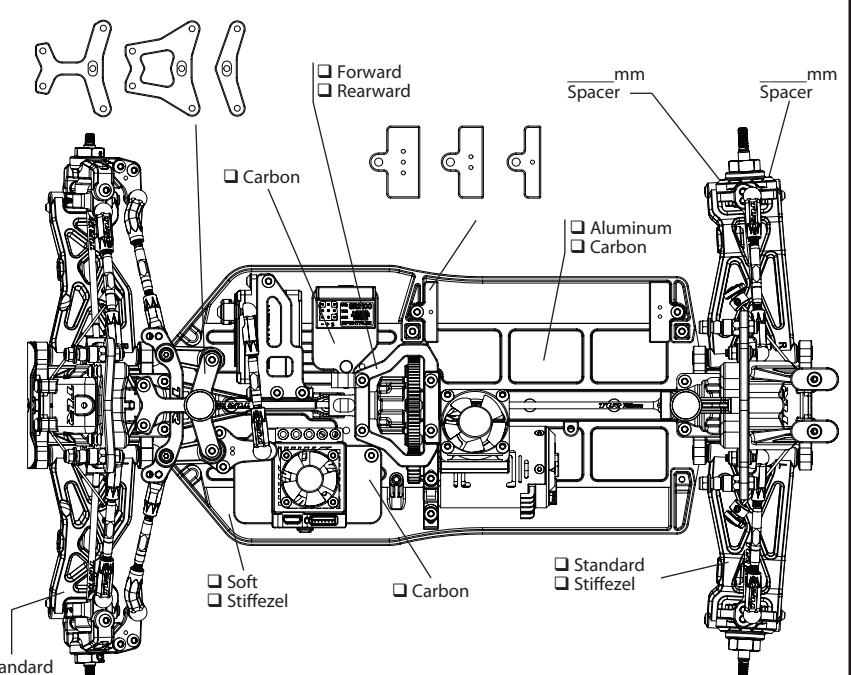

ELECTRONICS

Radio	ESC
Servo	Th Profile
Battery	Timing Adv
Battery Wt	g Initial Brake
Motor	Drag Brake
Gearing	Thr/Bra EPA

Total Weight: _____ g Fr/Rr _____ % / _____ %