

**TRACK CONDITIONS**

- Indoor  Clay  Carpet  Tight  Smooth  Hard Packed  Blue Groove  Wet Bite:  Low  Med  High  
 Outdoor  Dirt  Astro  Open  Rough  Loose/Loamy  Dry  Dusty Tread:  Pin  Ghost  Slick

Ride Height	<b>16</b>	mm
Camber	<b>-2</b>	°
Toe		°
Sway Bar	<b>1.1</b>	mm

**A and B Block Middle Hole**

Notes

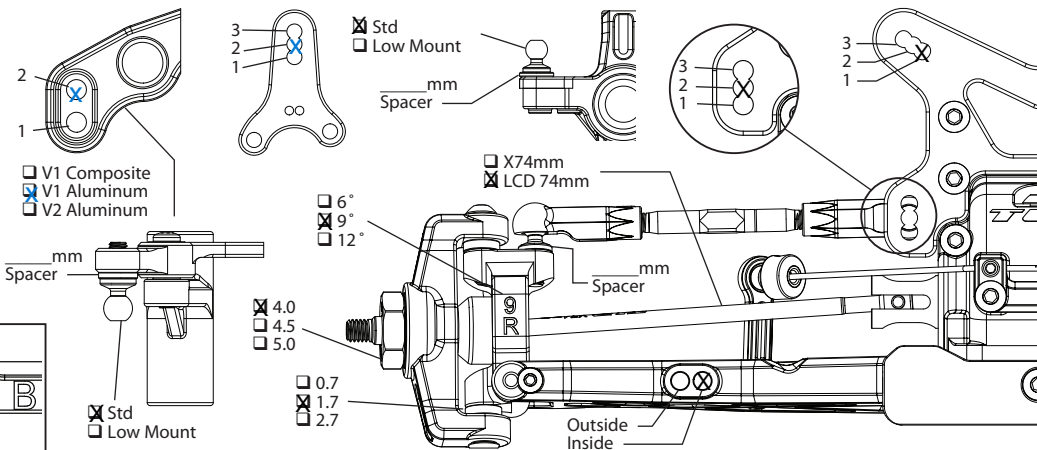

**REAR SUSPENSION**

Ride Height	<b>16</b>	mm
Camber	<b>-2</b>	°
Sway Bar		mm

**Middle Inside C and D Block**

Notes

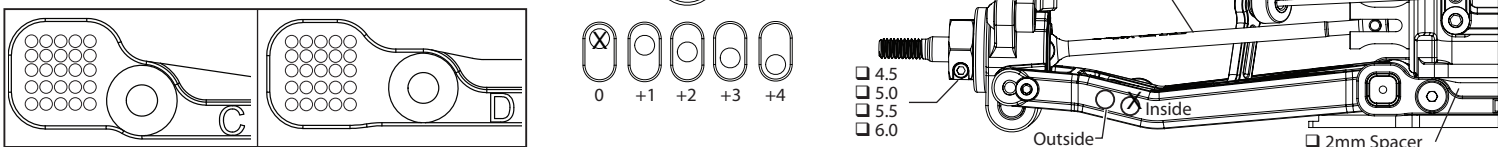

**CHASSIS**

DIFFERENTIALS			
	Front	Center	Rear
Fluid	<b>5</b>	<b>500</b>	<b>3</b>
Int Gears	<input type="checkbox"/> Stl <input type="checkbox"/> Comp	<input type="checkbox"/> Stl <input type="checkbox"/> Comp	<input type="checkbox"/> Stl <input type="checkbox"/> Comp
Weight	g	g	g
Ring/Pin	<input type="checkbox"/> Stl <input type="checkbox"/> Comp	<input type="checkbox"/> Stl <input type="checkbox"/> Comp	<input type="checkbox"/> Stl <input type="checkbox"/> Comp
Center Diff Cover	<input type="checkbox"/> Composite	<input type="checkbox"/> Aluminum	
Slipper Pads	<input type="checkbox"/> Torque/Yellow	<input type="checkbox"/> Drive/Orange	

AERODYNAMICS	
Body	<b>TLR</b>
Fr Scoop	<b>TLR</b>
Rr Wing	<b>J Concepts</b>
Wicker	<b>None</b>
Angle	<b>4</b> °
Notes	

TIRES	Front	Rear
Tyre	<b>Honeycomb</b>	<b>Honeycomb</b>
Compound	<b>Yellow</b>	<b>Yellow</b>
Insert	<b>Cragg Med</b>	<b>Cragg Med</b>
Sauce		
Wheel	<b>Schumacher</b>	<b>Schumacher</b>
Notes		

**SHOCKS**

	Front	Rear
Shock Caps	<b>G3</b>	<b>G3</b>
Oil	<b>350</b>	<b>300</b>
Piston	<b>1.5 Thin</b> <input type="checkbox"/> Thin	<b>1.6</b> <input type="checkbox"/> Thin
Limiters, Int	mm	mm
Shaft Dia	<input checked="" type="checkbox"/> 3.0mm <input type="checkbox"/> 3.5mm	<input checked="" type="checkbox"/> 3.0mm <input type="checkbox"/> 3.5mm
Limiters, Ext	mm	mm
Stroke	mm	mm
Eyelet	<input checked="" type="checkbox"/> Std <input type="checkbox"/> +2mm	<input checked="" type="checkbox"/> Std <input type="checkbox"/> +2mm
Spring	<b>Yellow</b>	<b>Pink</b>
Spring Cup	<input type="checkbox"/> Low <input checked="" type="checkbox"/> Mid <input type="checkbox"/> High	<input checked="" type="checkbox"/> Low <input type="checkbox"/> Mid <input type="checkbox"/> High

**ELECTRONICS**

Radio	ESC
Servo	Th Profile
Battery	Timing Adv
Battery Wt	g Initial Brake
Motor	Drag Brake
Gearing	Thr/Bra EPA

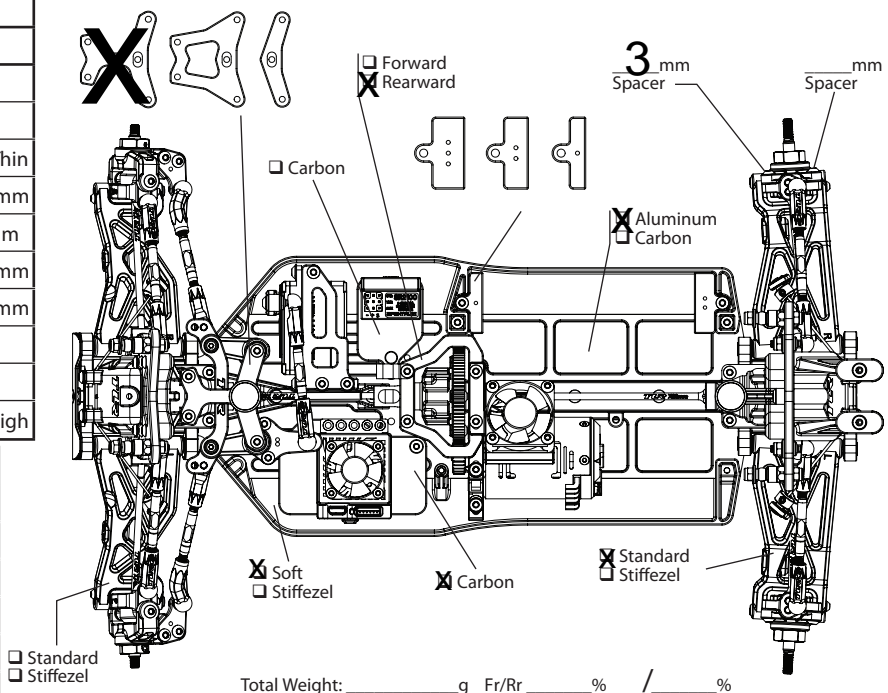

Total Weight: \_\_\_\_\_ g Fr/Rr \_\_\_\_\_ % / \_\_\_\_\_ %