

Name: _____ Date: _____ Event: _____ Track: _____

TRACK CONDITIONS

Indoor Clay Carpet Tight Smooth Hard Packed Blue Groove Wet **Bite:** Low Med High **Other:** _____
 Outdoor Dirt Astro Open Rough Loose/Loamy Dry Dusty **Tread:** Pin Ghost Slicks

FRONT SUSPENSION

Ride Height	mm
Camber	°
Toe	°
Sway Bar/Insert	/
Notes:	_____

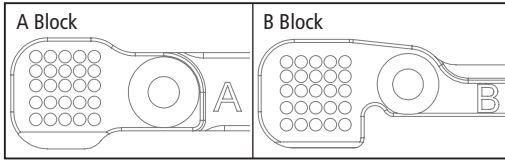
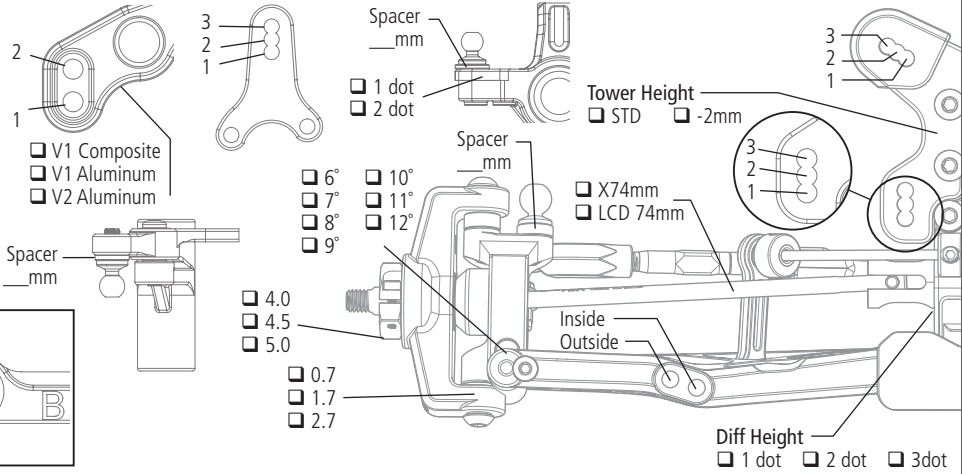

REAR SUSPENSION

Ride Height	mm
Camber	°
Sway Bar/Insert	/
Notes:	_____

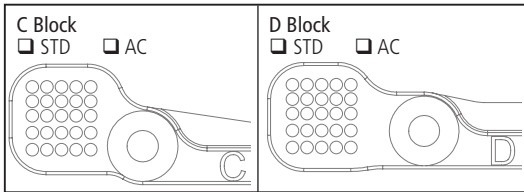
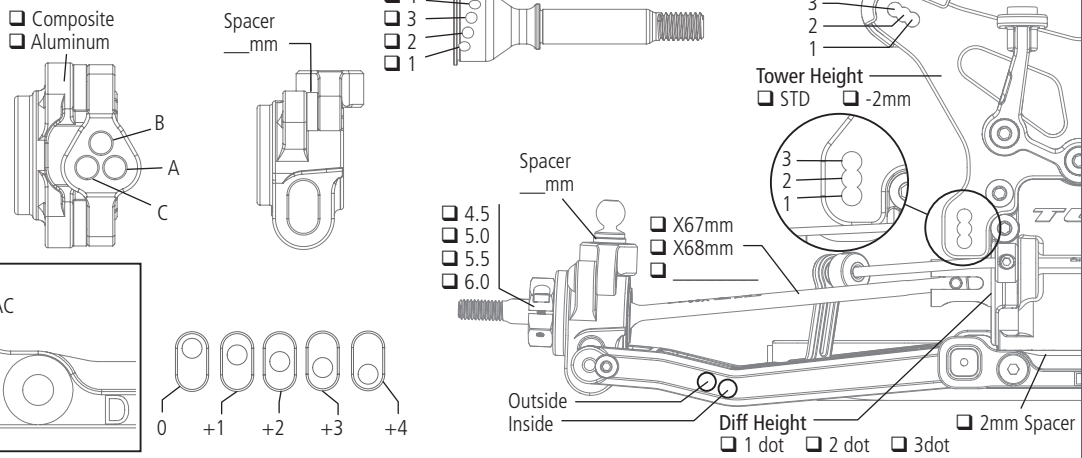

DIFFERENTIALS			
	Front	Center	Rear
Fluid/Setting			
Int Gears	<input type="checkbox"/> Stl <input type="checkbox"/> Comp	<input type="checkbox"/> Stl <input type="checkbox"/> Comp	<input type="checkbox"/> Stl <input type="checkbox"/> Comp
Weight	g	g	g
Ring/Pin	<input type="checkbox"/> Stl <input type="checkbox"/> Comp		<input type="checkbox"/> Stl <input type="checkbox"/> Comp
Center Diff Cover		<input type="checkbox"/> Composite <input type="checkbox"/> Aluminum	
Center Drive		<input type="checkbox"/> Dec Slip <input type="checkbox"/> Slip <input type="checkbox"/> Diff	

AERODYNAMICS	
Body	
Fr Scoop	
Rr Wing	
Wicker	
Angle	°
Notes	

TIRES		
	Front	Rear
Brand		
Tread		
Compound		
Insert		
Sauce		
Wheel		
Notes		

CHASSIS

SHOCKS			
	Front	Rear	
Oil	wt	wt	
Piston Holes	mm	mm	
Piston	<input type="checkbox"/> 2mm <input type="checkbox"/> 2.5mm	<input type="checkbox"/> 2mm <input type="checkbox"/> 2.5mm	
Limiters, Int			
Shaft Dia	<input type="checkbox"/> 3.0mm <input type="checkbox"/> 3.5mm	<input type="checkbox"/> 3.0mm <input type="checkbox"/> 3.5mm	
Limiters, Ext			
Stroke	mm	mm	
Eyelet	<input type="checkbox"/> Std <input type="checkbox"/> +2mm	<input type="checkbox"/> Std <input type="checkbox"/> +2mm	
Spring			
Spring Cup	<input type="checkbox"/> Low <input type="checkbox"/> Mid <input type="checkbox"/> High	<input type="checkbox"/> Low <input type="checkbox"/> Mid <input type="checkbox"/> High	

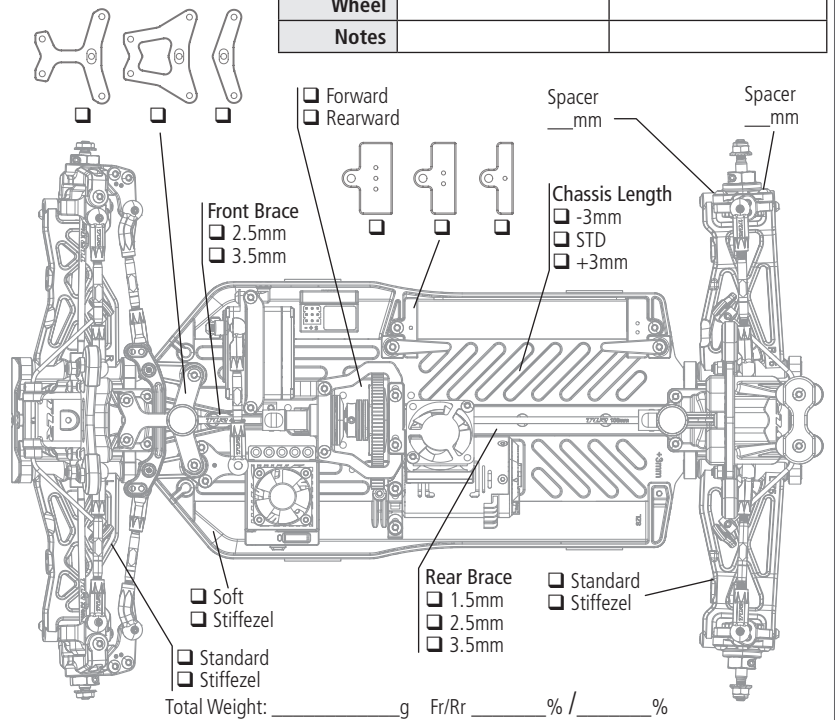

ELECTRONICS			
Radio		ESC	
Servo		Thro Prof	
Battery		Timing Adv	
Battery Wt	g	Initial Brake	
Motor		Drag Brake	
Gearing	/	Thr/Bra EPA	/