

NAME: _____		DATE: _____	EVENT: _____
CITY: _____	STATE: _____	TRACK: _____	



TRACK CONDITIONS	<input type="checkbox"/> Indoor	<input type="checkbox"/> Tight	<input type="checkbox"/> Smooth	<input type="checkbox"/> Hard Packed	<input type="checkbox"/> Blue Groove	<input type="checkbox"/> Wet	<input type="checkbox"/> Grass	<input type="checkbox"/> Low Bite	<input type="checkbox"/> High Bite
	<input type="checkbox"/> Outdoor	<input type="checkbox"/> Open	<input type="checkbox"/> Rough	<input type="checkbox"/> Loose/Loamy	<input type="checkbox"/> Dry	<input type="checkbox"/> Dusty	<input type="checkbox"/> Astroturf	<input type="checkbox"/> Med Bite	<input type="checkbox"/> Other _____

FRONT SUSPENSION

Toe: _____
 Ride Height: _____ Camber: _____
 Caster: 0° 5°
 Kick Angle: 20° 25° 30°
 VLA Setting: Short Arm Long Arm
 Front Pivot: Aluminum Plastic HRC HRC Aluminum
 Kick Shim: Brass Plastic
 Oil: _____ Piston: _____
 Spring: Standard Low Freq. Color: _____
 Sway Bar: 0.8mm 1.0mm 1.2mm _____
 Shock Limiters: _____ Stroke: _____
 Shock Locations: _____
 Spindle Ball Stud: Standard Low Mount
 Bump Steer Spacers: _____
 Ackerman Ball Stud: Standard Low Mount
 Ackerman Spacers: _____
 Ackerman Arm: #1 #2 #3 _____
 Trail: 2mm 3mm 4mm
 Camber Link: _____

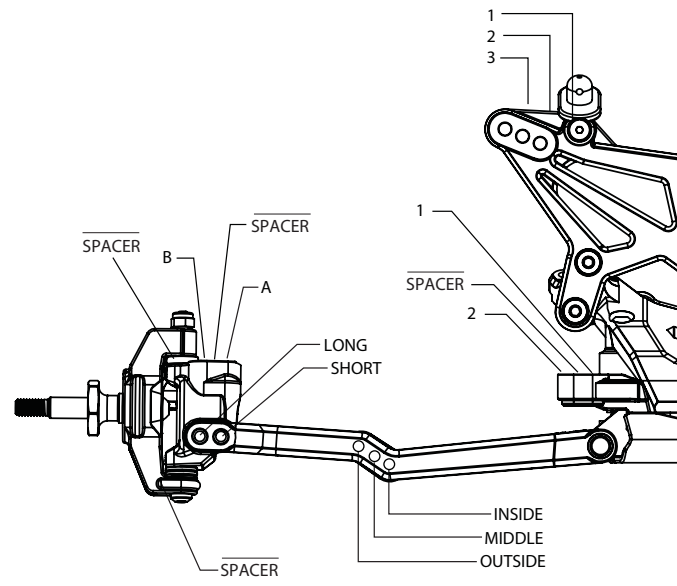

NOTES

REAR SUSPENSION

Configuration: Laydown Stand-Up
 LD Diff. Height: Standard +3.5mm
 Transmission Type: 3-Gear 4-Gear
 Toe Inserts: 0.5° 1° 1.5° 2° 2.5° 3° 3.5° 4°
 Anti-Squat Inserts: 0° 0.5° 1° 1.5° 2° 2.5° 3°
 Inner Roll Center: LRC HRC
 Ride Height: _____ Camber: _____
 Rear Hub Spacing: _____
 Rear Axle Height: Standard +3mm
 Hex Width: _____
 Sway Bar: 1.0mm 1.2mm 1.4mm _____
 Oil: _____ Piston: _____
 Spring: Standard Low Freq. Color: _____
 Shock Limiters: _____ Stroke: _____
 Shock Locations: _____
 Shock Mounting: Front Rear
 Inner Link Spacer: -1mm 0mm +1mm
 Camber Link: _____
 Battery Position: _____
 Diff Type: Ball Gear Setting: _____
 Driveshaft Length: CVA Universal Length: _____

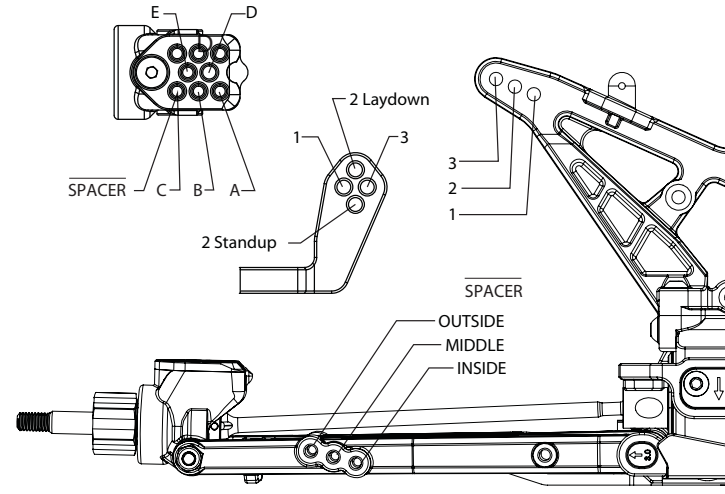

ELECTRONICS

Timing Advance: _____
 Radio: _____ Throttle/Brake Expo: _____
 Servo: _____ Servo Expo: _____
 ESC: _____ Throttle/Brake EPA: _____
 Initial Brake: _____ Motor: _____
 Drag Brake: _____ Pinion: _____ Spur: _____
 Throttle Profile: _____ Battery: _____

CHASSIS

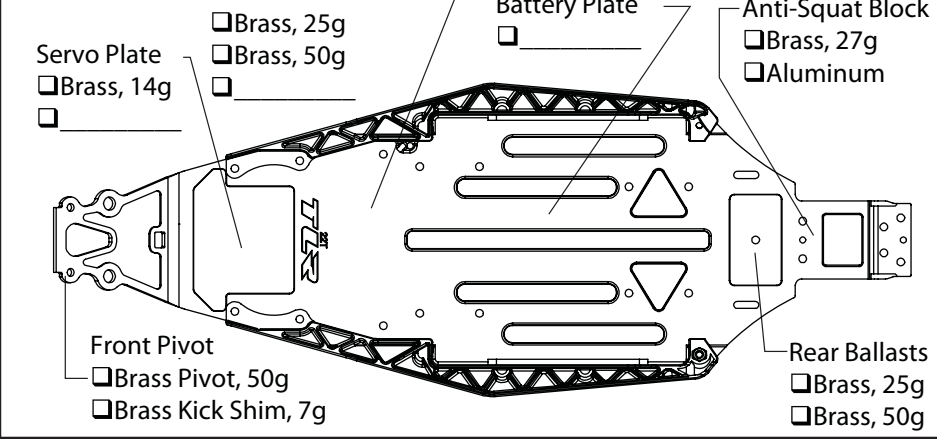

TIRES

	FRONT	REAR
Tire: _____	_____	_____
Compound: _____	_____	_____
Insert: _____	_____	_____
Additive: _____	_____	_____

NOTES

Arn0 at PetitRC.com