

Name _____ Date _____ Track / City _____ Event _____

Front Suspension

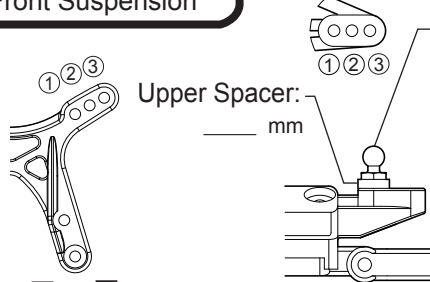

Upper Spacer: _____ mm

4.8mm Ball Stud: UM128 (Std) UMW508 (+2mm High Mount)

Camber: _____ °

Axle Spacer: Out _____ mm In _____ mm

4.8mm Ball Stud Spacer: _____ mm

Wheel Hub: _____ mm

Ackerman Steer Spacer: _____ mm

Bump Steer Spacer: _____ mm

Toe: In Out _____ °

Tie Rod: _____

Front Bulkhead Weight Placement: None Bulkhead Inside _____ oz _____ g On the skid plate _____ oz _____ g

Caster: 25° 30° 0.5 1.0 None 0° 2° 4° IN (wide/Std) OUT (Narrow)

25 08

Spacer: A (UM502) B (UM721/Std) C (UM567)

*1oz=28g

Front Axle: UM569 (RB6) UM506 (RB5)

Caster Block position: _____

Axle Height Spacer: _____ mm _____ mm

Wheelbase: F: _____ mm R: _____ mm

Comments: _____

Rear Suspension

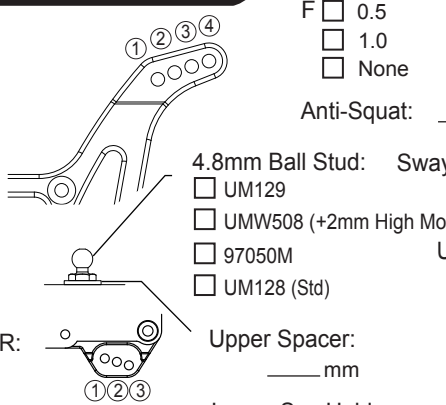

Sus Holder Spacer: F 0.5 1.0 None R 0.5 1.0 None

Anti-Squat: _____ °

4.8mm Ball Stud: UM129 UMW508 (+2mm High Mount) 97050M UM128 (Std)

Sway Bar: None _____ mm

Camber: _____ °

Upper Spacer: _____ mm

Wheelbase: F: _____ mm R: _____ mm

RR: _____

Mid: _____

Lower Sus Holder: Normal RF RF2 Aluminum(Opt) UMW511+UMW512 UMW514+UMW515

Universal Swing Shaft: _____

Axle Spacer: Out _____ mm In _____ mm

Arm: UM713 UM521 UM566 UM521-1 UM503

Rear Hub Toe: 0° 0.5° 1° UM519 UM519-2 Alu (UMW516) Alu (UMW704)

Motor Position: Rear Motor Midship Motor

Diff.: Gear Diff. # _____ Ball Diff.

Comments: _____

Shock

	Front			Rear		
Shock Piston:	_____	_____	_____	_____	_____	_____
Shock Oil:	# _____	_____	_____	# _____	_____	_____
Shock Spring:	_____	_____	_____	_____	_____	_____
Limiters:	in _____ mm	out _____ mm	_____ mm	in _____ mm	out _____ mm	_____ mm
Shock Length(A):	_____ mm	_____ mm	_____ mm	_____ mm	_____ mm	_____ mm
Shock Length(B):	_____ mm	_____ mm	_____ mm	_____ mm	_____ mm	_____ mm
O-ring:	_____	_____	_____	_____	_____	_____
Ball End type:	Front: S <input type="checkbox"/> M <input type="checkbox"/> L <input type="checkbox"/>	_____	_____	Rear: S <input type="checkbox"/> M <input type="checkbox"/> L <input type="checkbox"/>	_____	_____

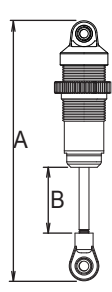

Battery Placement:

Comment: _____

○ None ● Screw

Front Rear

Foam: Front Rear None

Chassis

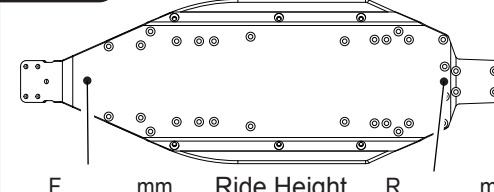

F _____ mm Ride Height R _____ mm

Battery Type

Straight Separate Short

Type: _____

Other

Motor: _____

ESC: _____

Pinion/Spur: _____

Tire

	Tire	Compound	Insert	Wheel
Front:	_____	_____	_____	_____
Rear:	_____	_____	_____	_____
Comment:	_____			

Comment

Track Condition

<input type="checkbox"/> Smooth	<input type="checkbox"/> Sandy
<input type="checkbox"/> Bumpy	<input type="checkbox"/> Soft Dirt
<input type="checkbox"/> Low Traction	<input type="checkbox"/> Grass
<input type="checkbox"/> Med.Traction	<input type="checkbox"/> BlueGroove
<input type="checkbox"/> High Traction	<input type="checkbox"/> Clay
<input type="checkbox"/> Wet	<input type="checkbox"/> Dusty
<input type="checkbox"/> Dry	<input type="checkbox"/> _____

Wing

Wing Mount : Narrow Wide

Wing Angle : 4° 7° 10°

Lip : _____