

Name \_\_\_\_\_ Date \_\_\_\_\_ Track / City \_\_\_\_\_ Event \_\_\_\_\_

### Front Suspension

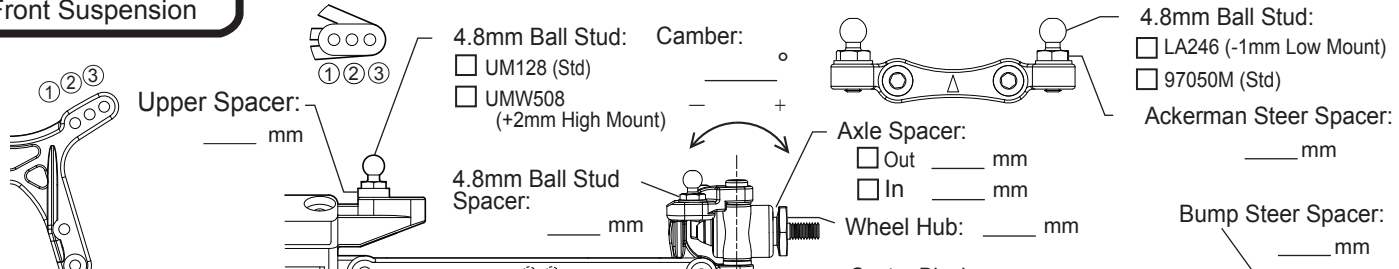

Upper Spacer: \_\_\_\_\_ mm

4.8mm Ball Stud:  UM128 (Std)  UMW508 (+2mm High Mount)

Camber: \_\_\_\_\_ °

Axle Spacer:  Out \_\_\_\_\_ mm  In \_\_\_\_\_ mm

4.8mm Ball Stud Spacer: \_\_\_\_\_ mm

Wheel Hub: \_\_\_\_\_ mm

Ackerman Steer Spacer: \_\_\_\_\_ mm

Bump Steer Spacer: \_\_\_\_\_ mm

Toe:  In  Out \_\_\_\_\_ °

Tie Rod: \_\_\_\_\_

Front Bulkhead Weight Placement:  None  Bulkhead Inside \_\_\_\_\_ oz \_\_\_\_\_ g  On the skid plate \_\_\_\_\_ oz \_\_\_\_\_ g

Caster:  25°  30°  0.5  1.0  None  0°  2°  4°  IN (wide/Std)  OUT (Narrow)

Caster Block position:  IN (wide/Std)  OUT (Narrow)

Axle Height Spacer:  \_\_\_\_\_ mm  \_\_\_\_\_ mm

Front Axle:  UM569 (RB6)  UM506 (RB5)

Comments: \_\_\_\_\_

Wheelbase: F: \_\_\_\_\_ mm R: \_\_\_\_\_ mm

### Rear Suspension

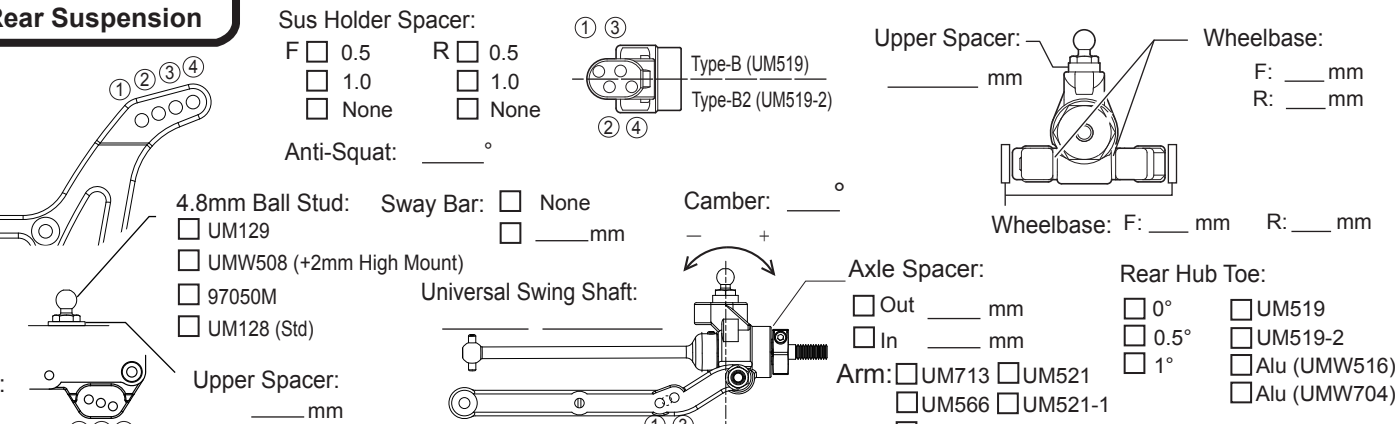

Sus Holder Spacer: F  0.5  1.0  None R  0.5  1.0  None

Anti-Squat: \_\_\_\_\_ °

4.8mm Ball Stud:  UM129  UMW508 (+2mm High Mount)  97050M  UM128 (Std)

Sway Bar:  None  \_\_\_\_\_ mm

Camber: \_\_\_\_\_ °

Upper Spacer: \_\_\_\_\_ mm

Wheelbase: F: \_\_\_\_\_ mm R: \_\_\_\_\_ mm

RR: \_\_\_\_\_

Mid: \_\_\_\_\_

Lower Sus Holder: Normal  RF  UMW511+UMW512  RM UMW705+UMW706: \_\_\_\_\_  RF2  UMW514+UMW515  MM UMW705+UMW707: \_\_\_\_\_ Aluminum(Opt)

Universal Swing Shaft: \_\_\_\_\_

Axle Spacer:  Out \_\_\_\_\_ mm  In \_\_\_\_\_ mm

Arm:  UM713  UM521  UM566  UM521-1  UM503

Rear Hub Toe:  0°  UM519  0.5°  UM519-2  1°  Alu (UMW516)  Alu (UMW704)

Comments: \_\_\_\_\_

### Motor Position

Rear Motor  Midship Motor

### Diff.

Gear Diff. # \_\_\_\_\_  Ball Diff.

### Shock

	Front			Rear		
Shock Piston:	_____	_____	_____	_____	_____	_____
Shock Oil:	# _____	_____	_____	# _____	_____	_____
Shock Spring:	_____	_____	_____	_____	_____	_____
Limiters:	in _____ mm	out _____ mm	_____	in _____ mm	out _____ mm	_____
Shock Length(A):	_____ mm	_____ mm	_____ mm	_____ mm	_____ mm	_____ mm
Shock Length(B):	_____ mm	_____ mm	_____ mm	_____ mm	_____ mm	_____ mm
O-ring:	_____	_____	_____	_____	_____	_____
Ball End type:	Front: S <input type="checkbox"/> M <input type="checkbox"/> L <input type="checkbox"/>			Rear: S <input type="checkbox"/> M <input type="checkbox"/> L <input type="checkbox"/>		

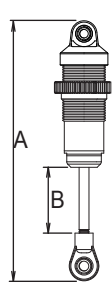

### Battery Placement:

Comment: \_\_\_\_\_

None  Screw

Front \_\_\_\_\_ Rear \_\_\_\_\_

Foam:  Front  Rear  None

### Battery Type

Straight  Separate  Short

Type: \_\_\_\_\_

### Chassis

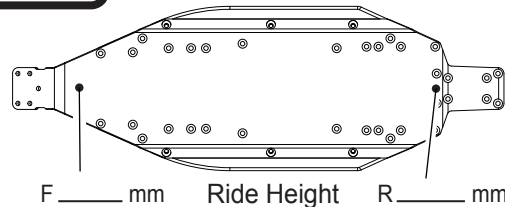

F \_\_\_\_\_ mm Ride Height R \_\_\_\_\_ mm

### Other

Motor: \_\_\_\_\_

ESC: \_\_\_\_\_

Pinion/Spur: \_\_\_\_\_

### Tire

	Tire	Compound	Insert	Wheel
Front:	_____	_____	_____	_____
Rear:	_____	_____	_____	_____
Comment:	_____			

### Comment

\_\_\_\_\_

\_\_\_\_\_

\_\_\_\_\_

### Track Condition

Smooth  Sandy  Bumpy  Soft Dirt  Low Traction  Grass  Med.Traction  BlueGroove  High Traction  Clay  Wet  Dusty  Dry

### Wing

Wing Mount:  Narrow  Wide

Wing Angle:  4°  7°  10°

Lip: \_\_\_\_\_