

Name _____	Date _____	Track / City _____	Event _____
------------	------------	--------------------	-------------

Front Suspension

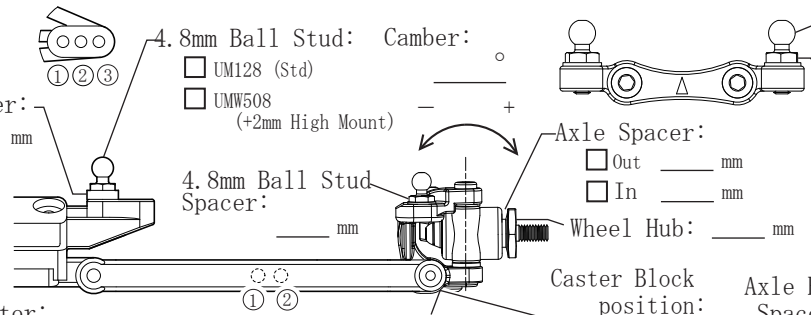

Upper Spacer: _____ mm



4.8mm Ball Stud: Camber: _____ °

UM128 (Std) UMW508 (+2mm High Mount)

4.8mm Ball Stud Spacer: _____ mm

Axle Spacer: Out _____ mm In _____ mm

Wheel Hub: _____ mm

Caster Block position: IN (wide/Std) OUT (Narrow)

Caster: 25° 30° 0.5 1.0 None 0° 2° 4°

Front Axle: UM569 (RB6) UM506 (RB5)

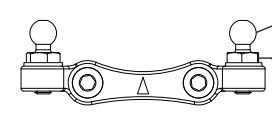

Ackerman Steer Spacer: _____ mm

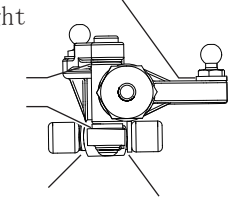

Bump Steer Spacer: _____ mm

Toe: In Out _____ °

Tie Rod: _____

Front Bulkhead Weight Placement: None Bulkhead Inside _____ oz _____ g On the skid plate _____ oz _____ g

A: (UM502) *1oz=28g B: (UM721/Std) C: (UM567)

Comments: _____

Wheelbase: F: _____ mm R: _____ mm

Rear Suspension

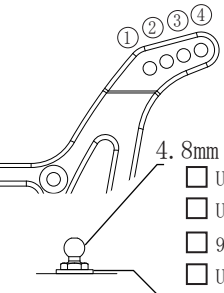

RR: _____

Mid: _____

Sus Holder Spacer: F 0.5 1.0 None R 0.5 1.0 None

Anti-Squat: _____ °

4.8mm Ball Stud: UM129 UMW508 (+2mm High Mount) 97050M UM128 (Std)

Sway Bar: None _____ mm

Camber: _____ °

Universal Swing Shaft: _____

Arm: UM713 UM521 UM566 UM521-1 UM503

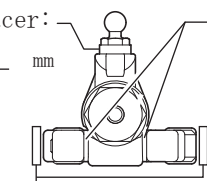

Upper Spacer: _____ mm



Wheelbase: F: _____ mm R: _____ mm

Upper Spacer: _____ mm

Lower Sus Holder: Normal RF RF2 Aluminum (Opt) UMW511+UMW512 UMW514+UMW515

Comments: _____

Shock

	Front		Rear	
Shock Piston:	_____	_____	_____	_____
Shock Oil:	# _____	# _____	# _____	# _____
Shock Spring:	_____	_____	_____	_____
Limiters:	in _____ mm	out _____ mm	in _____ mm	out _____ mm
Shock Length(A):	_____ mm	_____ mm	_____ mm	_____ mm
Shock Length(B):	_____ mm	_____ mm	_____ mm	_____ mm
0-ring:	_____	_____	_____	_____
Ball End type Front:	S <input type="checkbox"/> M <input type="checkbox"/> L <input type="checkbox"/>		S <input type="checkbox"/> M <input type="checkbox"/> L <input type="checkbox"/>	
Rear:	S <input type="checkbox"/> M <input type="checkbox"/> L <input type="checkbox"/>		S <input type="checkbox"/> M <input type="checkbox"/> L <input type="checkbox"/>	

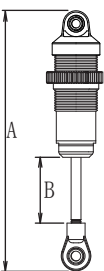

Battery Placement

Comment: _____

Front Rear

Foam: Front Rear None

Chassis

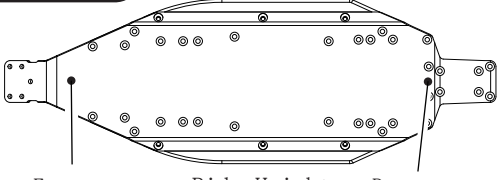

F: _____ mm Ride Height R: _____ mm

Battery Type

Straight Separate Short

Type: _____

Other

Motor: _____

ESC: _____

Pinion/Spur: _____

Track Condition

<input type="checkbox"/> Smooth	<input type="checkbox"/> Sandy
<input type="checkbox"/> Bumpy	<input type="checkbox"/> Soft Dirt
<input type="checkbox"/> Low Traction	<input type="checkbox"/> Grass
<input type="checkbox"/> Med. Traction	<input type="checkbox"/> BlueGroove
<input type="checkbox"/> High Traction	<input type="checkbox"/> Clay
<input type="checkbox"/> Wet	<input type="checkbox"/> Dusty
<input type="checkbox"/> Dry	<input type="checkbox"/> _____

Wing

Wing Mount: Narrow Wide

Wing Angle: 4° 7° 10°

Lip: _____

Tire	Tire	Compound	Insert	Wheel
Front: _____	_____	_____	_____	_____
Rear: _____	_____	_____	_____	_____
Comment: _____	_____	_____	_____	_____
Comment: _____	_____	_____	_____	_____