

BJ4 WORLDS EDITION SET-UP SHEET:

DRIVER Jared Tebo

DATE March 17-19, 2006

TRACK/CITY SRS Raceway

EVENT 2006 Cactus Classic

NOTES:

Used optional rear std. thickness .055" sway bar.



TRACK CONDITIONS:

SOFT SURFACES: HARD SURFACES:

SAND / SOIL	WET <u>X</u> (Morning)
LOAMY	HARD SLICK
RUTS	ABRASIVE <u>X</u>
WET	BLUE GROOVE
DRY	BLACK GROOVE <u>X</u>
	BROKEN <u>X</u>

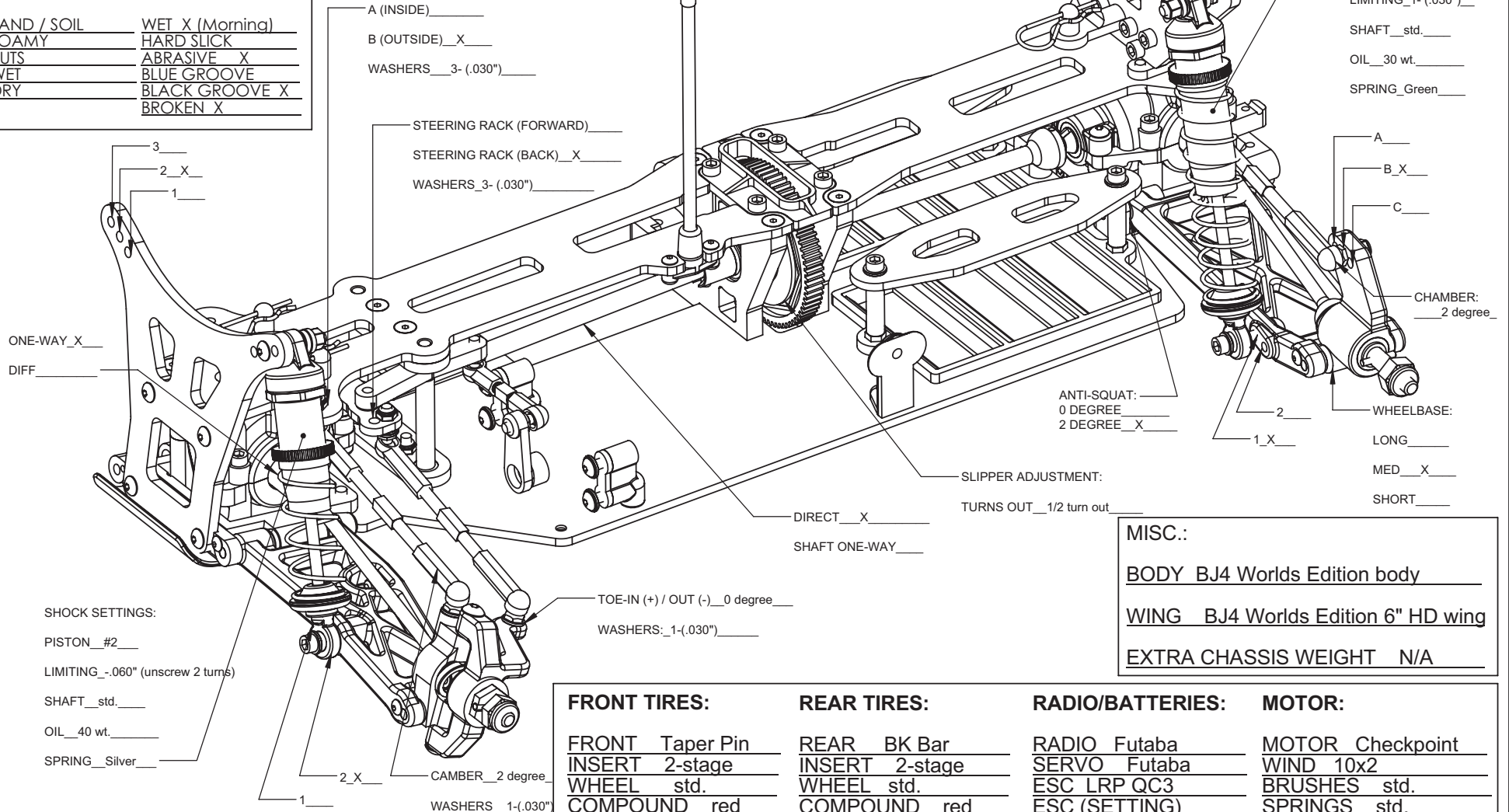

MISC.:
 BODY BJ4 Worlds Edition body
 WING BJ4 Worlds Edition 6" HD wing
 EXTRA CHASSIS WEIGHT N/A

FRONT TIRES:	REAR TIRES:	RADIO/BATTERIES:	MOTOR:
FRONT <u>Taper Pin</u>	REAR <u>BK Bar</u>	RADIO <u>Futaba</u>	MOTOR <u>Checkpoint</u>
INSERT <u>2-stage</u>	INSERT <u>2-stage</u>	SERVO <u>Futaba</u>	WIND <u>10x2</u>
WHEEL <u>std.</u>	WHEEL <u>std.</u>	ESC <u>LRP QC3</u>	BRUSHES <u>std.</u>
COMPOUND <u>red</u>	COMPOUND <u>red</u>	ESC (SETTING) <u> </u>	SPRINGS <u>std.</u>
ADDITIVE <u>N/A</u>	ADDITIVE <u>N/A</u>	BATTERIES <u>Checkpoint</u>	PINON/SPUR <u>18x78</u>