

NAME NOM David Poulter

DATE DATUM DATE 10th December 2011

SETUP BLATT FICHE DE RÉGLAGE V1.0 E

EVENT VERANSTALTUNG EVENT Winter Ireland Race 2011

TRACK STRECKE PISTE The Naul - Dublin - Ireland

AIR TEMP UMGEBUNGSTEMP. TEMPÉRATURE DE L'AIR 6°C

TRACK SIZE STRECKENGRÖSSE TAILLE DE LA PISTE Medium

SURFACE STRECKENBELAG TYPE DE SURFACE Astro

TRACTION LEVEL GRIFF ADHÉRENCE Very High

CONDITIONS WETTER NIVEAU D'HYDROMÉTRIE Dry/Cold

RIDE HEIGHT BODENFREIHEIT GARDE AU SOL
mm

CAMBER ANGLE STURZ ANGLE DE CARROSSAGE
-1 °

TOE IN/OUT VONSPUR/NACHSPUR ANGLE DE PINCEMENT
+/- 0 °

SWAY BAR STABILISATOR BARRE ANTI-ROULIS
None mm

SWAY BAR LINK STABILISATOR HEBELANGE LIEN DE LA BARRE ANTI-ROULIS
mm

WISHBONE DROOP AUSFEDERWEG/ACHSE DROOP DES TRIANGLES ARRIÈRES
Max mm

NOTES NOTIZEN REMARQUES

FRONT VORN AVANT

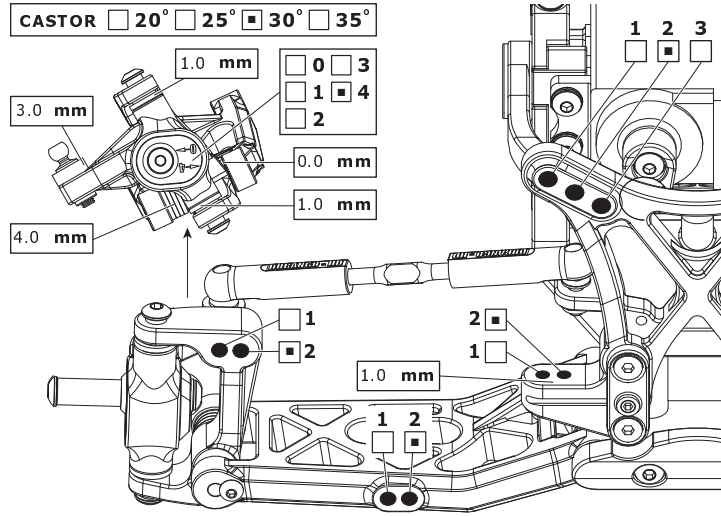

RIDE HEIGHT BODENFREIHEIT GARDE AU SOL
mm

CAMBER ANGLE STURZ ANGLE DE CARROSSAGE
-1 °

SWAY BAR STABILISATOR BARRE ANTI-ROULIS
None mm

SWAY BAR LINK STABILISATOR HEBELANGE LIEN DE LA BARRE ANTI-ROULIS
mm

WISHBONE DROOP AUSFEDERWEG/ACHSE DROOP DES TRIANGLES ARRIÈRES
Max mm

NOTES NOTIZEN REMARQUES

REAR HINTEN ARRIÈRE

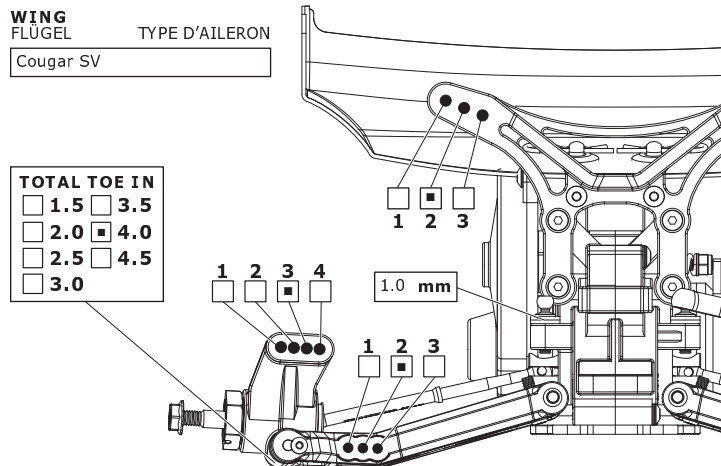

MOTOR MOTOR MOTEUR
Orion 7.5T

SPUR GEAR HAUPTZAHNRAD COURONNE
Kit 87T

PINION GEAR RITZEL PIGNON
25T

BATTERY AKKU ACCUMULATEUR
Orion 6500 90C

ESC SETTINGS REGLER PROGRAMM RÉGLAGE DU VARIATEUR

DIFF. TYPE DIFF. TYP TYPE DE DIFF.
 BALL

DIFF. OIL DIFF. ÖL HUILE DE DIFF.
cst

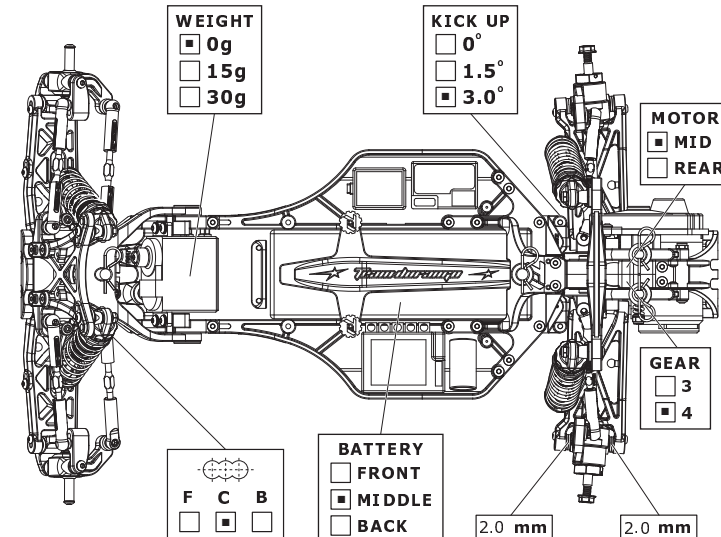

FRONT SHOCKS VORNE DÄMPFER AMORTISSEURS AVANTS



SPRINGS FEDERN RESSORTS
Dark Red

REBOUND REBOUND REBOND
10 %

PRELOAD FEDERVORSpannung PRÉCONTRAINTÉ
4 mm

OIL WT. ÖLVISKOSITÄT VISCOSITÉ
550 cst

PISTON KOLBEN PISTON
4 Hole @ 1.3mm

LENGTH LÄNGE LONGUEUR
mm

NOTES NOTIZEN REMARQUES
Tapered

REAR SHOCKS HINTEN DÄMPFER AMORTISSEURS ARRIÈRES



SPRINGS FEDERN RESSORTS
Light Red

REBOUND REBOUND REBOND
10 %

PRELOAD FEDERVORSpannung PRÉCONTRAINTÉ
5 mm

OIL WT. ÖLVISKOSITÄT VISCOSITÉ
500 cst

PISTON KOLBEN PISTON
5 Hole @ 1.3mm

LENGTH LÄNGE LONGUEUR
mm

NOTES NOTIZEN REMARQUES
Tapered

TYRES REIFEN PNEUS

FRONT REAR
BRAND HERSTELLER MARQUE
Schumacher | Schumacher

TREAD PROFIL PROFIL
Cut Stagger | MiniSpike

COMPOUND MISCHUNG DURETÉ
Yellow | Yellow

INSERT EINLAGEN MOUSSE
Mr O Foams - Blue | Mr O Foams - Blue

WHEEL FELGE JANTE
Durango | Durango 14mm

NOTES NOTIZEN REMARQUES
Slipper = 1.5mm
Rear = 45mm Wide

RESULTS PLATZIERUNG RÉSULTAT QUALIFYING POSITION 6th FINAL POSITION 5th

AVERAGE LAP BEST LAP RACE TIME