

NAME NOM David Poulter

DATE DATUM DATE 13th November 2011

SETUP BLATT FICHE DE RÉGLAGE V1.0 E

EVENT VERANSTALTUNG EVENT Snowman Series Round 3

TRACK STRECKE PISTE Broxtowe

AIR TEMP UMGEBUNGSTEMP. TEMPÉRATURE DE L'AIR 11°C

TRACK SIZE STRECKENGRÖSSE TAILLE DE LA PISTE Medium

SURFACE STRECKENBELAG TYPE DE SURFACE Astroturf with Sand

TRACTION LEVEL GRIFF ADHÉRENCE Med to Low

CONDITIONS WETTER NIVEAU D'HYDROMÉTRIE Damp

RIDE HEIGHT BODENFREIHEIT GARDE AU SOL
20 mm

CAMBER ANGLE STURZ ANGLE DE CARROSSAGE
-1 °

TOE IN/OUT VONSPUR/NACHSPUR ANGLE DE PINCEMENT
+/- 0 °

SWAY BAR STABILISATOR BARRE ANTI-ROULIS
None mm

SWAY BAR LINK STABILISATOR HEBELANGE LIEN DE LA BARRE ANTI-ROULIS
mm

WISHBONE DROOP AUSFEDERWEG/ACHSE DROOP DES TRIANGLES ARRIÈRES
Max mm

NOTES NOTIZEN REMARQUES

RIDE HEIGHT BODENFREIHEIT GARDE AU SOL
22 mm

CAMBER ANGLE STURZ ANGLE DE CARROSSAGE
-1 °

SWAY BAR STABILISATOR BARRE ANTI-ROULIS
None mm

SWAY BAR LINK STABILISATOR HEBELANGE LIEN DE LA BARRE ANTI-ROULIS
mm

WISHBONE DROOP AUSFEDERWEG/ACHSE DROOP DES TRIANGLES ARRIÈRES
Max mm

NOTES NOTIZEN REMARQUES

FRONT VORN AVANT

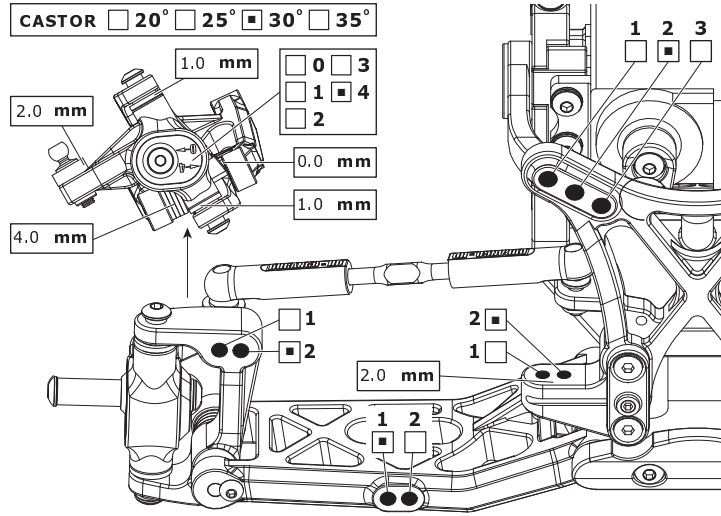

REAR HINTEN ARRIÈRE

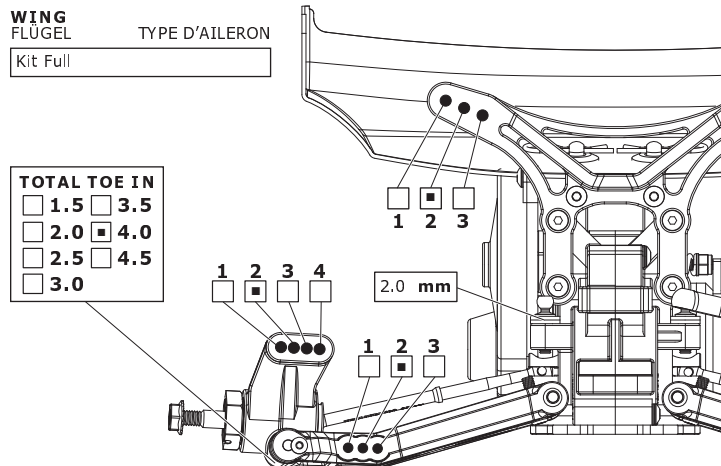

MOTOR MOTOR MOTEUR
Orion 6.5T

SPUR GEAR HAUPTZAHNRAD COURONNE
Kit 87T

PINION GEAR RITZEL PIGNON
24T

BATTERY AKKU ACCUMULATEUR
Orion Carbon Pro 6500 90C

ESC SETTINGS REGLER PROGRAMM RÉGLAGE DU VARIATEUR

DIFF. TYPE DIFF. TYP TYPE DE DIFF.
 BALL

DIFF. OIL DIFF. ÖL HUILE DE DIFF.
cst

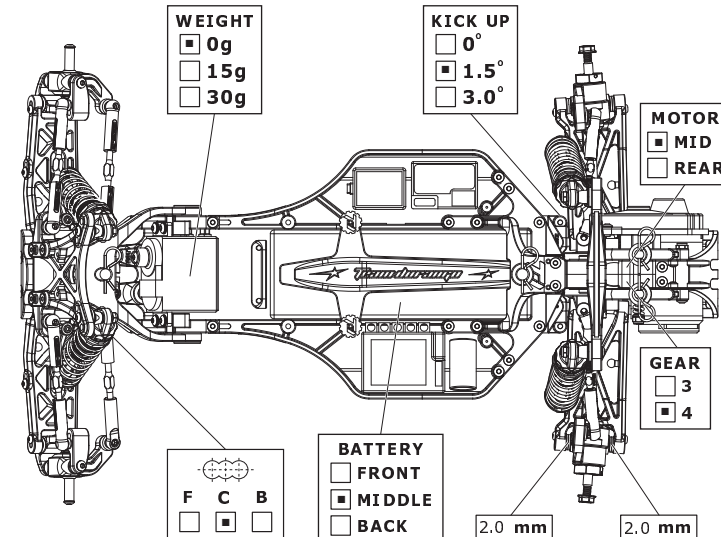

FRONT SHOCKS

VORNE DÄMPFER AMORTISSEURS AVANTS



BIG BORE
 SLIM BORE

SPRINGS FEDERN RESSORTS

Dark Red

REBOUND REBOUND REBOND

10 %

PRELOAD FEDERVORSpannung PRÉCONTRAINTÉ

5.5 mm

OIL WT. ÖLVISKOSITÄT VISCOSITÉ

550 cst

PISTON KOLBEN PISTON

4 Hole @ 1.3mm

LENGTH LÄNGE LONGUEUR

mm

NOTES NOTIZEN REMARQUES

Tapered

REAR SHOCKS

HINTEN DÄMPFER AMORTISSEURS ARRIÈRES

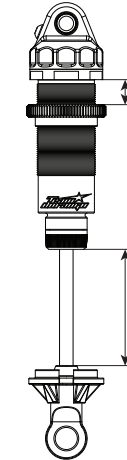

BIG BORE
 SLIM BORE

SPRINGS FEDERN RESSORTS

Light Red

REBOUND REBOUND REBOND

10 %

PRELOAD FEDERVORSpannung PRÉCONTRAINTÉ

9 mm

OIL WT. ÖLVISKOSITÄT VISCOSITÉ

500 cst

PISTON KOLBEN PISTON

5 Hole @ 1.3mm

LENGTH LÄNGE LONGUEUR

mm

NOTES NOTIZEN REMARQUES

Tapered

TYRES REIFEN PNEUS

FRONT | REAR

BRAND HERSTELLER MARQUE

Schumacher | Schumacher

TREAD PROFIL PROFIL

MiniSpike | MiniSpike

COMPOUND MISCHUNG DURETÉ

Green | Green

INSERT EINLAGEN MOUSSE

Mr O Foams - Blue | Mr O Foams - Blue

WHEEL FELGE JANTE

Durango | Durango 14mm Hex

NOTES NOTIZEN REMARQUES

RudeBits Under Lipo Weight 66g

No Spikes off

RESULTS PLATZIERUNG RÉSULTAT QUALIFYING POSITION A5 FINAL POSITION A2

AVERAGE LAP BEST LAP RACE TIME

DURCHSCHNITTZEIT SCHNELLESTE RÜNDE REINWDAUER