

Front Suspension:

Ride Height: _____

Toe: _____ Hex: _____

Anti-Roll Bar

Size: _____

Gap: _____

Ackerman

1 2 3 4 01

Steering Arm Plate:

Drive Shaft: CVAs: Universals:

Notes:

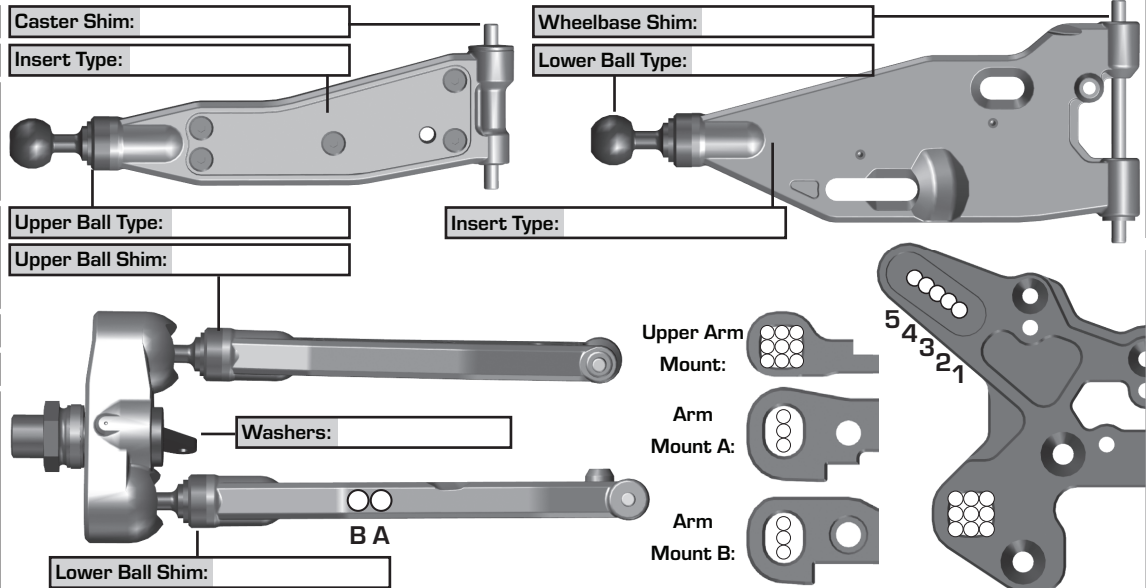

Rear Suspension:

Ride Height: _____

Camber: _____ Hex: _____

Anti-Roll Bar

Size: _____

Gap: _____

Drive Shaft: CVAs: Universals:

Chassis Brace

Pivot Type: _____

Insert Type: _____

Notes:

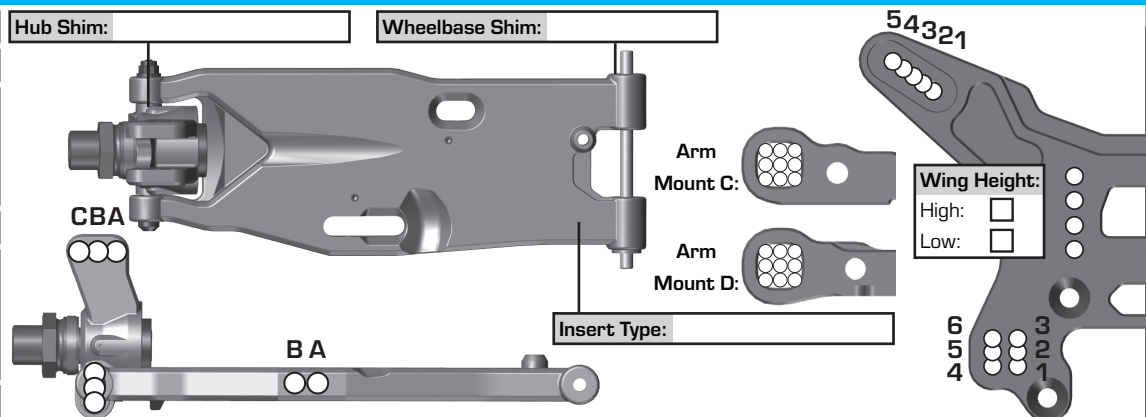

Electronics:

Radio: _____ Servo: _____

EPA: Throttle: _____ % Brake: _____ %

EXPO: Throttle: _____ % Brake: _____ %

ESC: _____ Motor: _____

Battery: Saddle Brick

Battery Position: Rear Center Forward

Battery Tray Position: Rear Forward

Notes:

Differential:

	Front	Center	Rear
Fluid:			
Gears:			
Mass:			
Notes:			

Gearing:

Spur Gear: _____ Pinion: _____

Notes:

Shocks:

	Front	Rear
Piston:		
Fluid:		
Bladder:		
Rebound:		
Spring:		
Length:		
Eyelet:		
Notes:		

Length

Rebound

Track Info:

Size: Small Medium Large Extra Large

Surface: Dirt Carpet AstroTurf Multi Surface

Traction: Low Medium High Very High

Moisture: Dry Damp Wet

Condition: Indoor Outdoor Dusty Hard Packed
 Bumpy Grooved Smooth Loamy

Temperature: Ambient: _____ Track: _____

Notes:

Tires:

Front Tire/Compound/Insert/Wheel: _____

Rear Tire/Compound/Insert/Wheel: _____

Notes:

Body and Wing:

Body: _____

Rear Wing: _____

Angle: 0° 2° 4° Button: Flat Fin

Vent Holes: _____

Weight:

Total Weight: _____

Notes:

Vehicle Comments:

Notes: _____