

THE ALL NEW



A NEW TECHNOLOGICAL BREAKTHROUGH FROM TEAM ASSOCIATED

RC10T TRUCK
INSTRUCTION MANUAL

The New RC10T Racing Technology

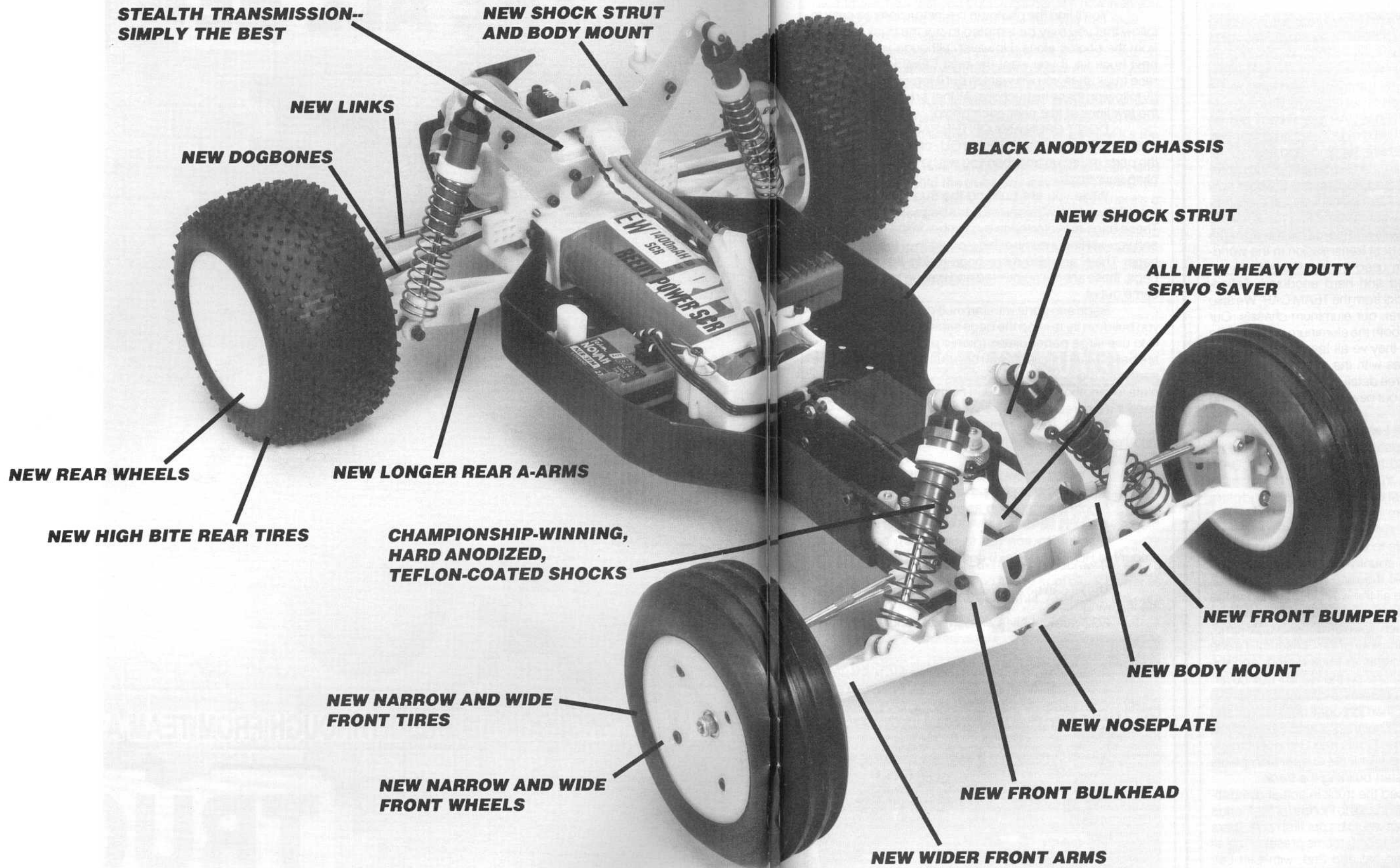

Advanced, Competition Design

FIRST, A WORD

Team Associated's RC10 2WD car has won three IFMAR WORLD CHAMPIONSHIPS, including the 1991 race in Detroit, MI. For Australia, in 1989, we had developed a totally new transmission called the STEALTH transmission. This STEALTH tranny was also used in the '91 race in Detroit and is part of our latest RC10, the TEAM CAR. Out of the box, the TEAM CAR has already proven it's the best. At the 1990 ROAR NATIONALS in Livermore, Calif., it finished an impressive 1st, 2nd, and 3rd.

We've used the same WORLD CHAMPIONSHIP-winning design concepts and engineered a whole new vehicle, the RC10T Truck. This is definitely not a conversion kit, as you'll find out when assembling the truck. As you can tell, we did use a few important parts from the TEAM CAR. We used the best transmission in the world—the STEALTH tranny. We used the best shocks in the world, our new, improved and hard anodized, Teflon-coated race-winning shocks from the TEAM CAR. We also used another speed secret, our aluminum chassis. Our Team drivers have tested both the aluminum and graphite chassis extensively, and they've all learned that they're getting their best lap times with the standard aluminum chassis. Pages two and three detail all the totally new parts that were required to build our new championship-winning RC10T.

Roger Curtis, Cliff Lett and Curtis Husting used their combined design experience from the TEAM CAR to design a truck that would handle like our TEAM CAR. Although ROAR's racing truck class is called Monster Truck, it was easy to see that what was actually raced more closely resembled Stadium Trucks.

Anyone who has seen the Stadium Trucks race know how exciting they are to watch. All sixteen races in stadiums all around the country are always sold out, proving their popularity. At the race at the Los Angeles Coliseum, the trucks climb all the way up to the top of the bleachers, through the peristyle end, come charging out through an archway and then down an unbelievable jump, three to four stories tall, to the floor of the Coliseum! It's one of the more spectacular sights in truck racing, and the reason we depicted this scene on the RC10T box cover.

We looked at the truck rules and found out what we were allowed to do, and then brought our design and racing experience to design our truck. Curtis Husting built three prototype trucks. Then Curtis and Cliff put in many hours of track time fine tuning all the suspension points before we were ready to start building the truck.

We still hadn't raced the truck in actual competition before we took the three trucks to Florida for the Florida Winter Championships. This would be our first race. There were 450 entries with all the racing teams present. The all new RC10T trucks finished 1st and 2nd, with Cliff Lett winning and Butch Kloeber following in 2nd! It was an

incredible finish, justifying all our long hard work. We are certainly very well pleased with the RC10T and we know you will be too.

You'll find the photos in the instructions so easy to follow that you may be tempted to put the truck together from the photos alone. However, although you have the best truck kit, if you want the best COMPLETED model race truck, then you will want to put it together correctly—by following these instructions. All that's required is to read the few lines of text near each photo.

DON'T OPEN ANY OF THE PARTS BAGS UNTIL THESE INSTRUCTIONS TELL YOU, otherwise you'll get the parts mixed up and then you will have trouble assembling your truck.

While you are building the truck you will sometimes be working with several parts bags at the same time. These bags are referred to by number in the instructions, and you will find a number label on each of the main parts bags. There are also more bags inside the main parts bags; these are not numbered and belong to the bag they came out of.

Bags and parts will start multiplying like rabbits as you build, so try to keep the bags separate. One good way is to use large paper plates (picnic plates with partitions are best). Mark the plates with bag numbers and dump the parts into them. When the parts are used up, relabel the plate for another bag. It's much easier to find the part you need if it's spread out where you can see it.

TOOLS. The kit contains the shock wrench and all the Allen wrenches you'll need, but you will have to supply the following:

- #2 Phillips screwdriver (Associated #SP76)
- A needle-nose pliers
- A hobby knife, such as an X-acto with a pointed blade
- A soldering iron (25 to 50 watts), and a small amount of ROSIN (not acid) core 60/40 solder.

The kit can be assembled even easier if you have the following:

- 3/32" straight Allen wrench with handle. Will make installing the Allen screws much faster and easier (Associated #SP73)
- A ruler with decimal inches or metric measure
- A 3/16" nut driver will make installing the ball ends easier (Associated #SP86)
- A 1/4" nut driver will speed up installing the 1/4" nuts (#SP85)
- Socket or open-end wrench
- Small screwdriver
- Thread-locking compound
- ZAP or Hot Stuff (cyanoacrylate adhesive)
- Vise
- File
- Drill with #43 (2.3 mm) bit

WARNING! Do not use a power screwdriver. They

spin too fast, causing screws to heat up when being driven into plastic and will strip out.

Take your time assembling the truck. It's not a race to see how fast you put it together; it's how well you put it together that determines how fast you can race.

Boxes at each step are provided so you can put a check mark for each assembly after each step is completed. So when you stop during assembly time, you'll be able to come back and start in the correct step.

To help you identify certain parts, an outline drawing occasionally will accompany the step. Just place your part atop the actual-size drawing to be sure it's the one referred to.

One final note for you experienced builders and racers: **please build the truck our way first!!** The RC10T is a remarkably fast truck right out of the box. There's a reason for everything on the truck, and very few compromises were made in its design. Work with the truck first and see what it can do before you experiment or make changes.

Clear off your workbench, line up some paper plates, grab a sandwich, and *let's begin...*



ASSOCIATED ELECTRICS, INC.
3585 CADILLAC AVE.
COSTA MESA, CA 92626

FRONT END ASSEMBLY

Fig. 1 From Bags 6-14 and 7-1 screw the #6273 long ball end into the left hand #6213 front block carrier as shown, then screw on the #7260 nut. Assemble the right hand parts.

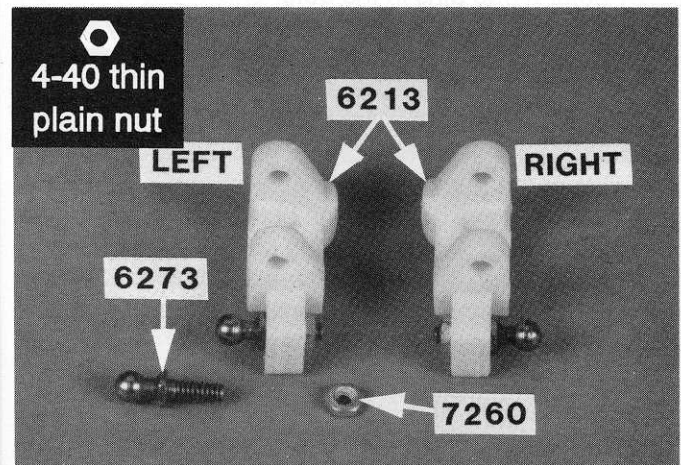

Fig. 1

Fig. 2 Again from Bag 6-14 and 7-1, screw the short #6270 ball end into the #6217 steering block and secure it with the #7260 nut as shown. Assemble the right hand side.

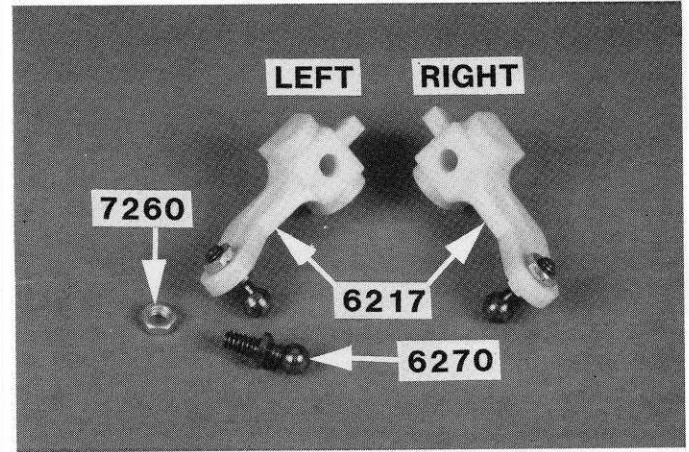

Fig. 2

Fig. 3 Push the #6218 front axle from Bag 7-1 into the #6217 steering block as shown so the hole in the axle lines up with the hole in the steering block. It may push together with your fingers. If not, LIGHTLY tap it into the hole. Assemble the right hand side in the same way.

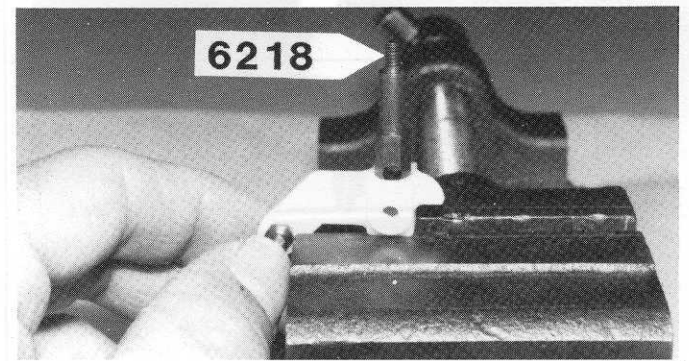

Fig. 3

□ **Fig. 4** You'll notice that the hex part of the axle does not go all the way into the steering block. That's O.K. Just make sure the hole in the axle is lined up with the hole in the steering block.

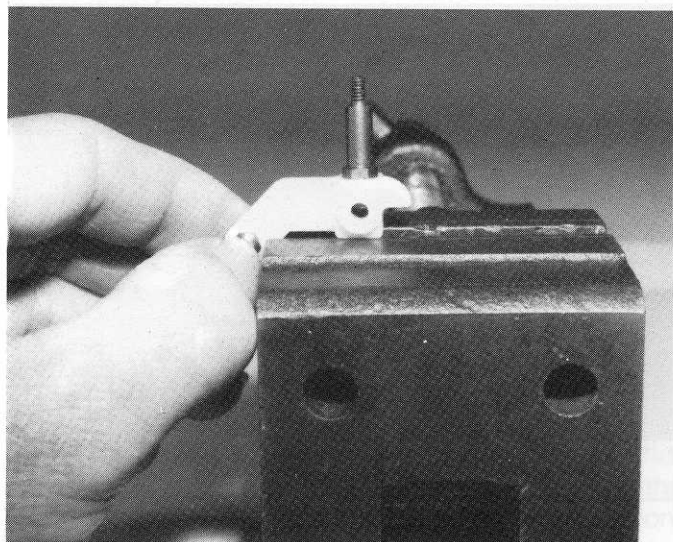

Fig. 4

□ **Figs. 5, 6 & 7** Line up the steering block in the block carrier as shown, and push the #6223 king pin (from Bag 7-1) through. The pin will be loose in the block carrier, but will be snug in the steering block. We want it that way. You might have to lightly tap it in.

Fig. 7 shows a package of #6299 E-clips. Remove two from the package and install an E-clip on each end of the pin. If you run out of E-clips, there are extras in the shock bags. Assemble the right hand side.

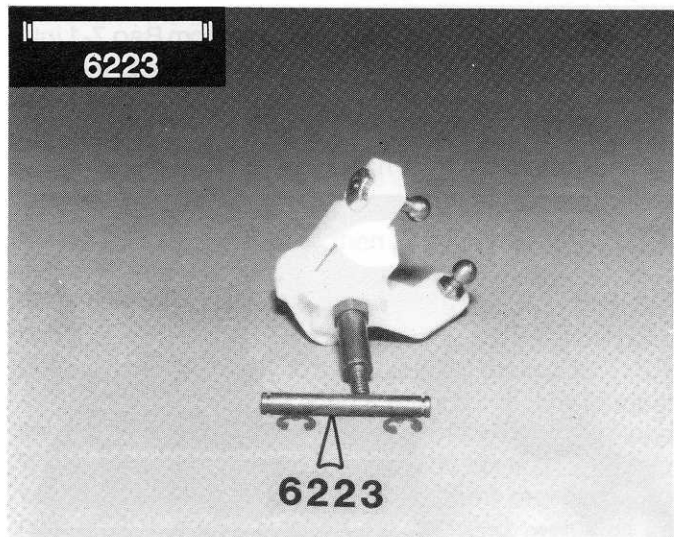

Fig. 5

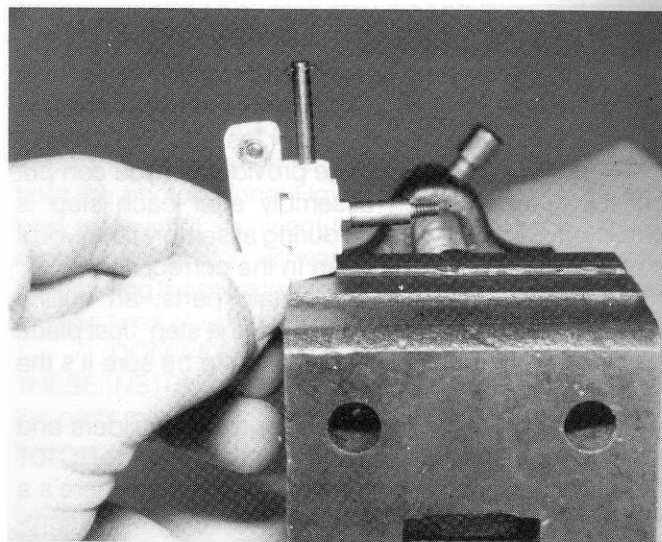

Fig. 6

6299 →

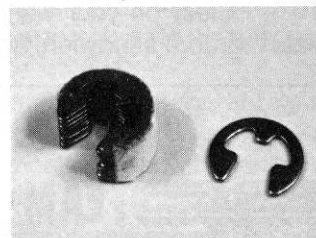

Fig. 7

□ **Figs. 8 & 9** Again from Bag 7-1, try one of the #6227 outer hinge pins in the outer end of the #7206 left hand front A-arm. Your front and rear a-arms may be in a separate, un-numbered bag. (The left hand and right hand sides of the truck are determined like this: with the driver sitting in the driver's seat, on the driver's left hand is the left hand side of the truck and on his right hand is the right hand side of the truck.)

After you've pushed one of the #6227 pins in the outside end of the A-arm, hold the pin and see if the arm will swing freely on the pin. Most racers keep a .126" and a #30 (.1285") reamer in their toolbox to free up A-arm holes and to clean them after racing.

But we want the pin to fit tight in the #6213 front block carrier, so do not ream it out. Now, assemble the block carrier assembly to the outer A-arm with the hinge pin and install two E-clips on the pin. Do the right hand side.

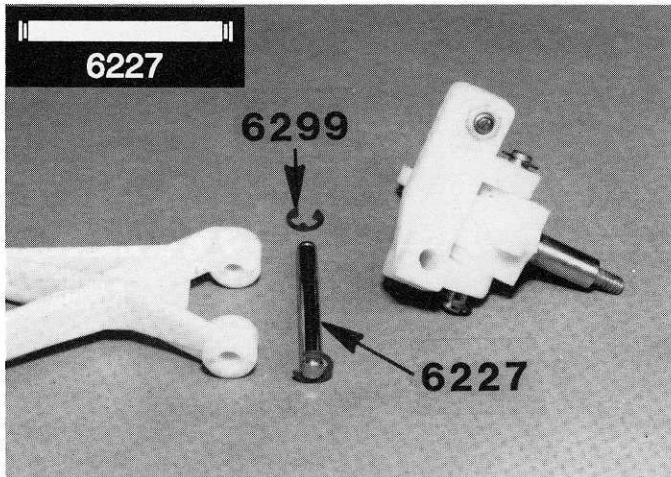

Fig. 8

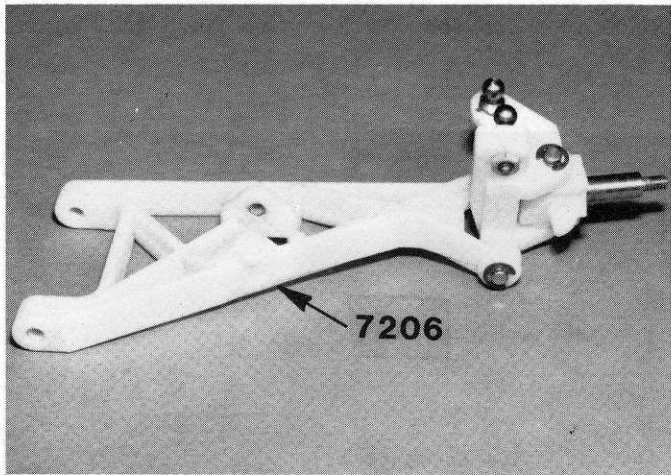

Fig. 9

□ **Figs. 10 & 11** From Bag #7-1 take out the #7207 front bulkhead, the #7208 aluminum support and the #7209 inner hinge pins. Try the pins in the A-arms again and see how they fit. Free them up if necessary. We want the pins to be tight in the bulkhead. Assemble the front arms to the bulkhead as shown. Secure with e-clips.

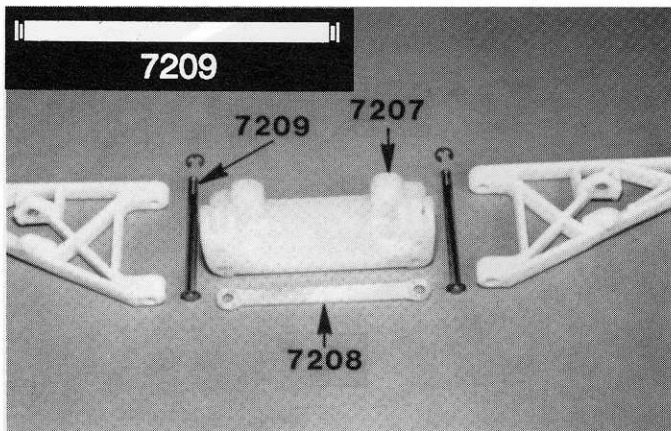

Fig. 10

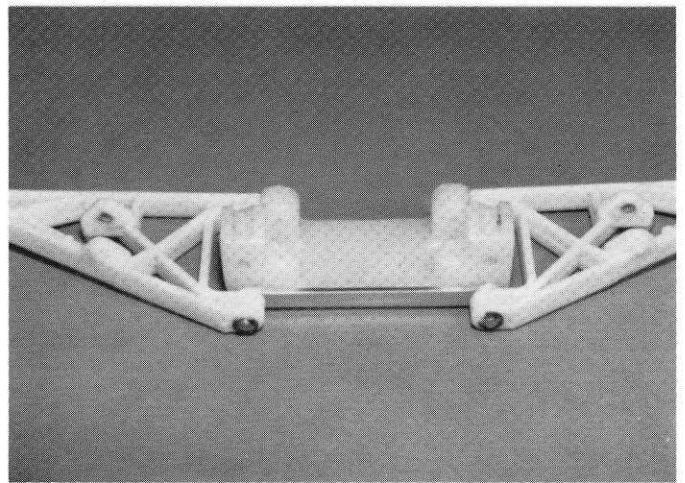

Fig. 11

□ **Figs. 12 & 13** From Bag 6-14 and 7-1, take the #7214 front shock strut and install two of the #6270 ball ends, with the short threads, into the strut in the locations shown. Tighten the ball ends, and then install and tighten two #7260 plain nuts on the ball end threads. With the two 4/40 x 1/2" screws, install the shock strut to the bulkhead as shown. It will be a lot quicker and easier to install the 4/40 screw with a #SP73 3/32 screwdriver handle allen wrench.

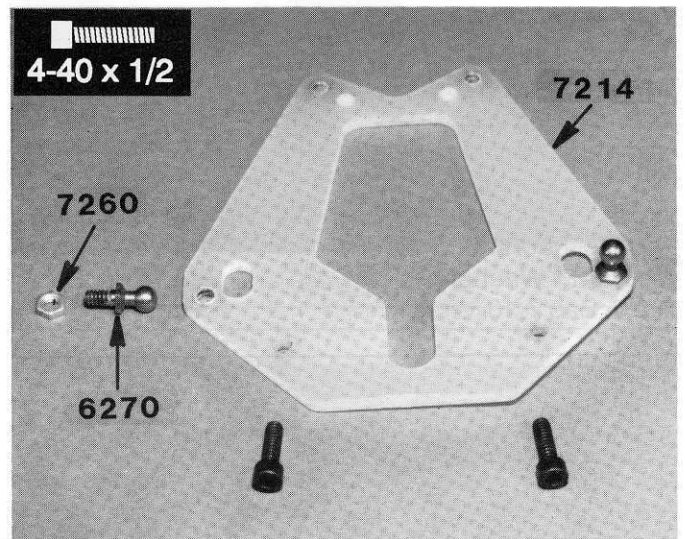

Fig. 12

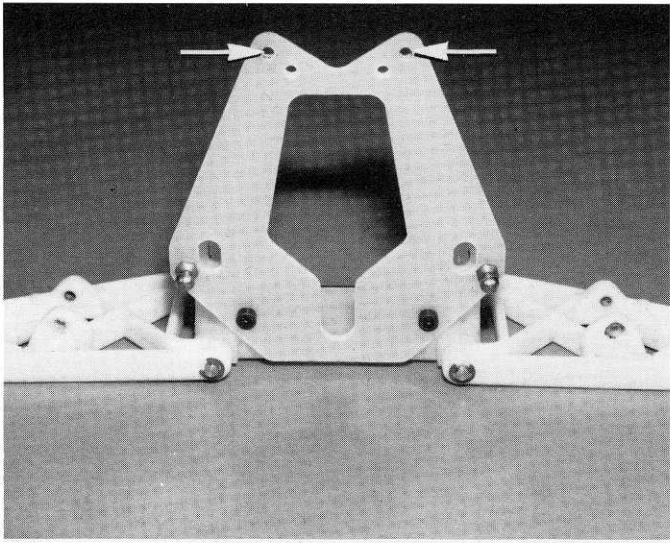

Fig. 13

□ Figs. 13 & 13A

Install and tighten two 4/40 x 3/4" socket head screws, from Bag 7-10, in the upper outer holes, as shown. From the same bag remove two 4-40 plain nuts and two #4 flat washers and install and tighten onto the screws as shown. You may wish to add washers on either side of the shock strut for added support. Washers are in Bag 7-10.

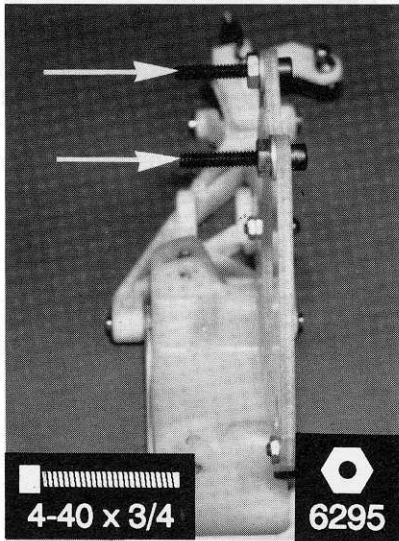

Fig. 13A

□ Fig. 14 From Bag 6-14 twist and remove four of the #6274 ball ends from the tree and screw them onto two long #7253 turnbuckles. The turnbuckles have right hand threads on one end and left hand threads on the other end, so they'll screw on in different directions. This will allow us to simply turn the turnbuckles to make adjustments later.

Screw the plastic rod ends on evenly until you come to the dimensions shown in the photo. *Remember, these dimensions are to the CENTER of the ball, NOT to the end of the ball cup.* These upper suspension links are used to adjust the camber of the car.

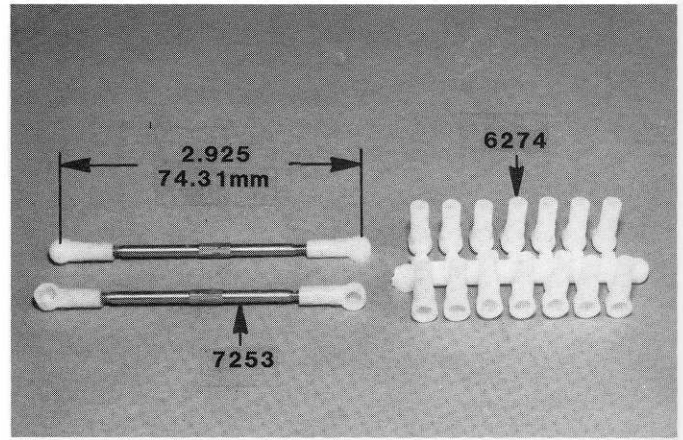

Fig. 14

□ Fig. 15 Use a pliers or needle nose pliers and snap the ball ends onto the steel balls as shown.

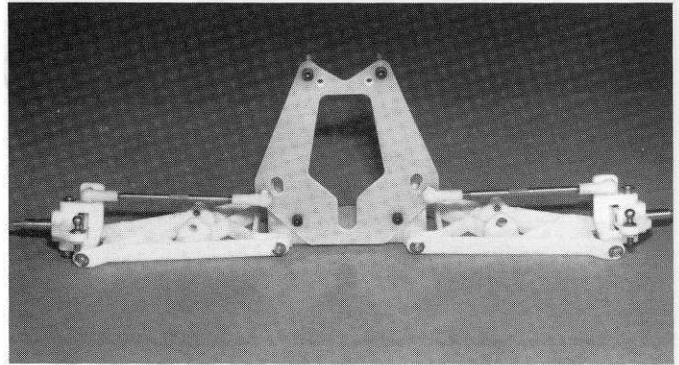

Fig. 15

□ Fig. 16 The rod ends can be removed quite easily from the balls by holding the rod end with a pliers, as shown, and twisting the rod end off the ball, as shown.

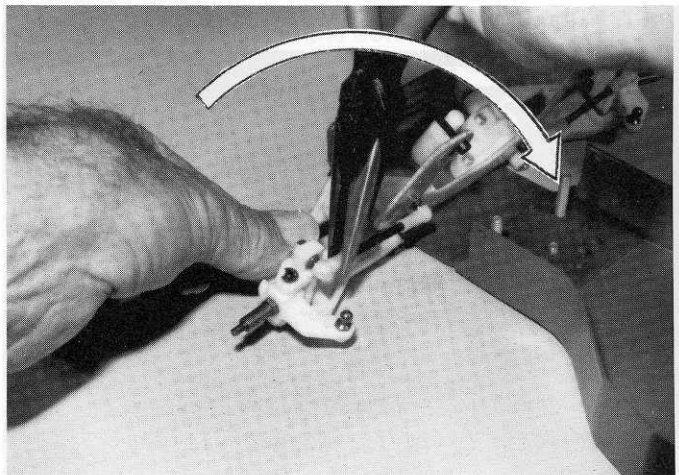

Fig. 16

□ **Figs. 17 & 18** From Bag 7-4 remove the #7305 chassis nose plate. Use the four 8/32 x 1/2" aluminum screws from Bag 7-1 as shown. Install the nose plate to the bottom of the front bulkhead with the four screws. Use a #2 Philips screwdriver and tighten the screws all the way up until they're snug. **DO NOT OVERTIGHTEN.** If you try to tighten them too tight, you'll strip out the plastic.

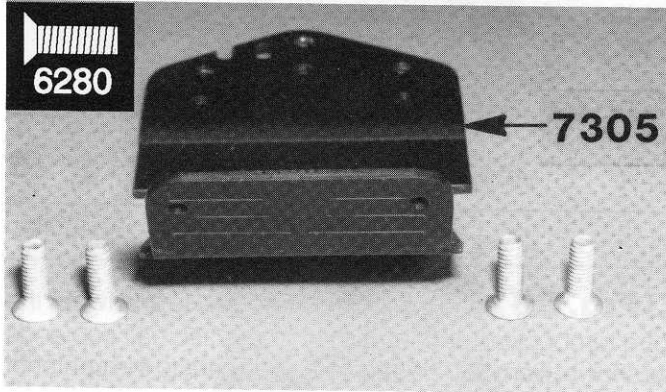

Fig. 17

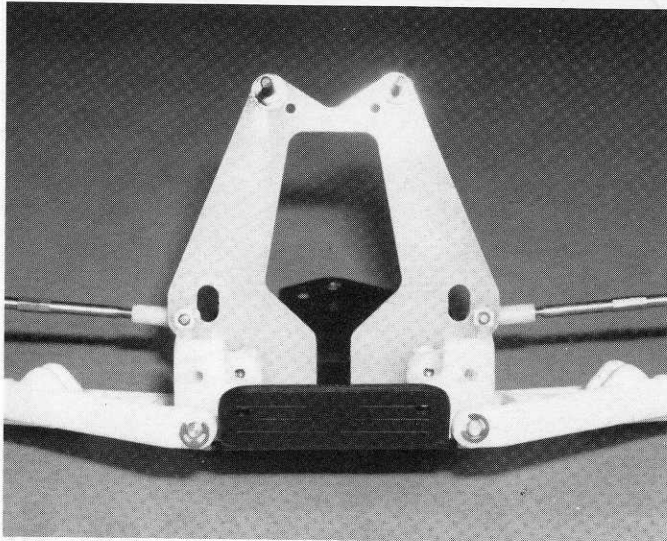

Fig. 18

□ **Figs. 19 & 20** From Bag 7-4 remove the short silver 8-32 flat head screw. Then, from Bag 7-2, the two longer steel screws. The long screws are two different lengths and have a short threaded shank by the screw head, a smooth center shaft, and then a threaded end.

Attach the front end assembly to the #6301 black anodized chassis using the set of three chassis holes towards the rear. Refer to fig. 147. The longest screw goes on the left hand side. Tighten the three screws.

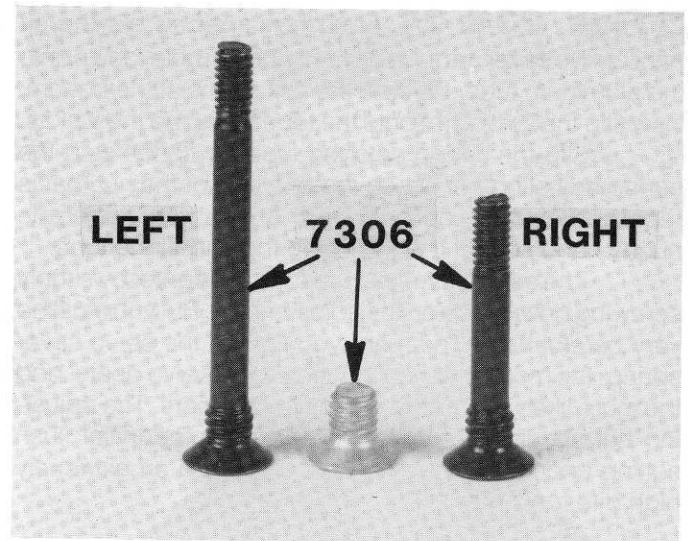

Fig. 19

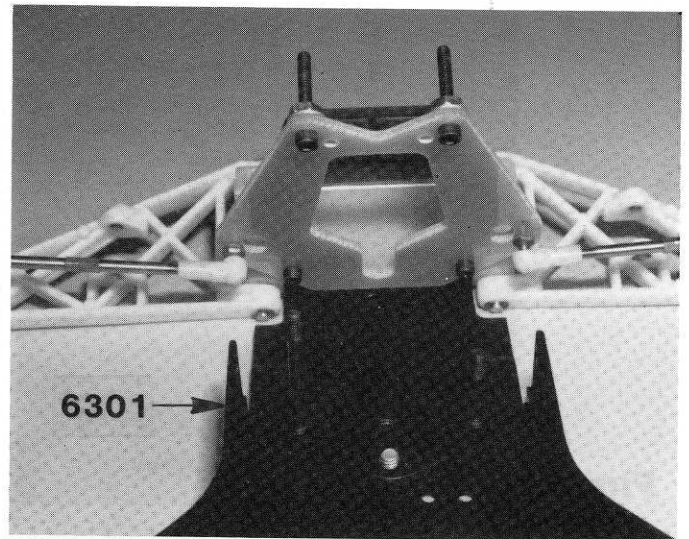

Fig. 20

□ **Figs. 21 & 22**

From Bag 7-2 take out the #7250 servo saver parts. Push the two plastic bushings into the aluminum threaded tube as shown.

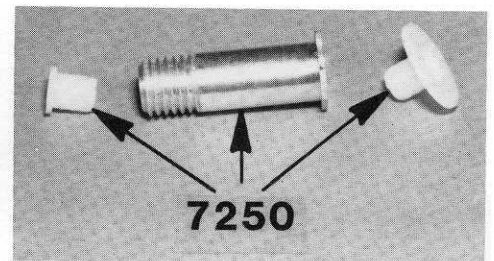

Fig. 21

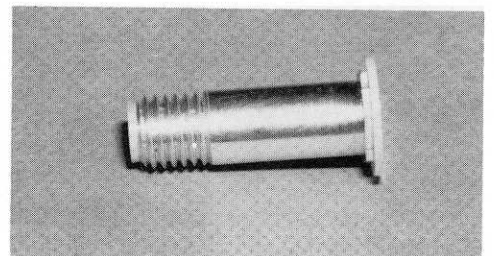

Fig. 22

□ **Figs. 23 & 24** From the same bag, slip the left hand servo saver arm, the one with the big hole, down onto the aluminum tube. Be sure the hex aligns at the bottom. Now slip the servo arm onto the tube, lining up the V slots.

Slip the spring onto the tube, and then start the spring adjusting nut on, so that the part of the nut that is recessed to go around the spring goes on first. Tighten the nut by hand so that it is flush with the end of the tube.

The servo saver can be adjusted tighter by simply screwing down more on the adjusting nut. But you must be very careful here. The more you tighten the servo saver spring, the more load you transfer to the servo gears, and the more likely you'll strip out the servo gears. The adjusting nut should only be adjusted below the initial flush setting under limited racing conditions on an extremely high bite track.

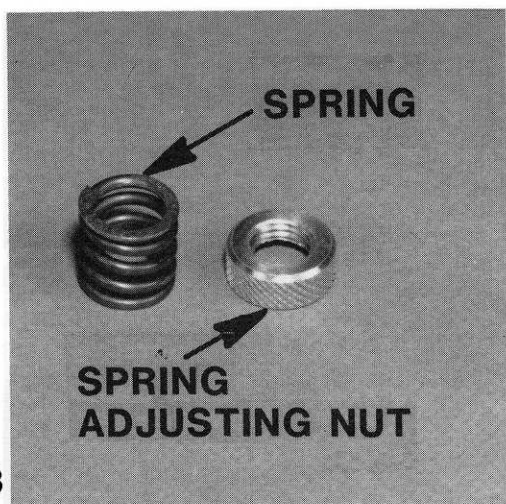

Fig. 23

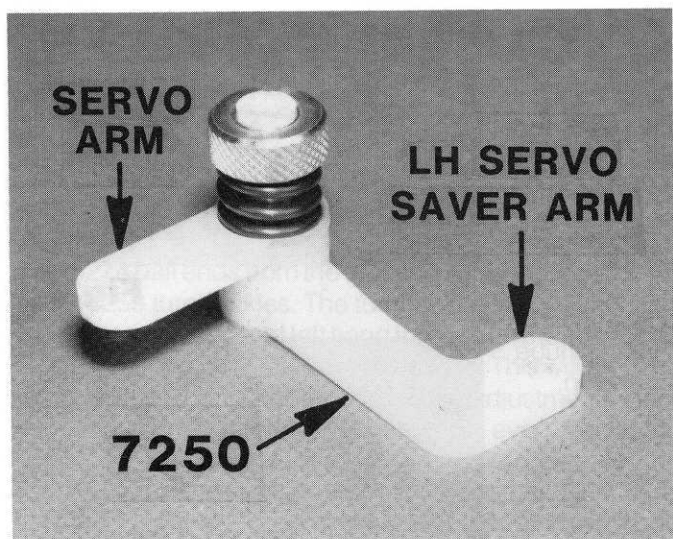

Fig. 24

□ **Fig. 25** Install five of the #6270 steel ball ends with the short threads in the locations shown.

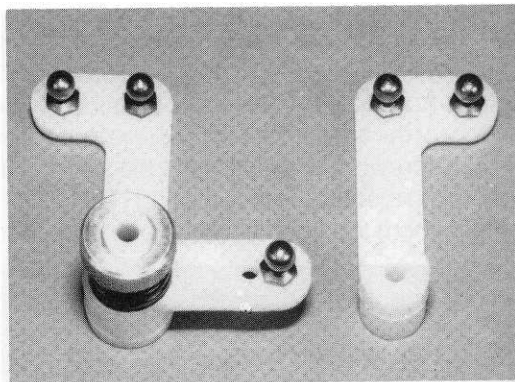

Fig. 25

□ **Fig. 26** Take the shortest turnbuckle and two of the long turnbuckles and thread on the plastic ball cup ends as shown. Remember, the dimensions are to the center of the ball, NOT to the end of the ball cup.

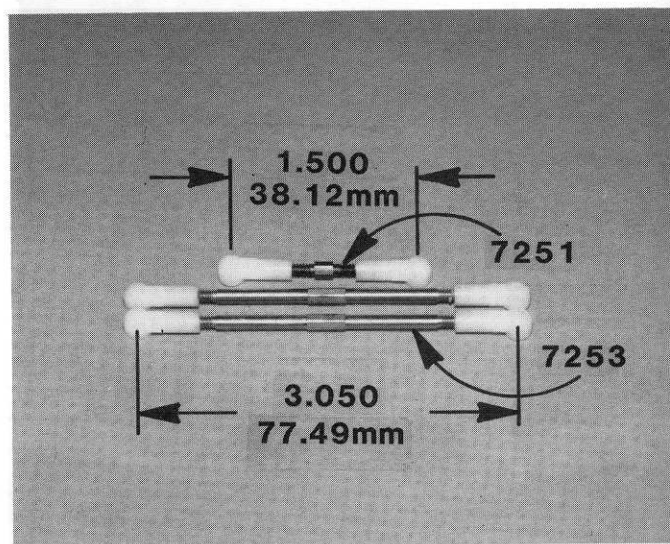

Fig. 26

□ **Fig. 27** Take the short turnbuckle and snap it on the two ball ends, as shown, using pliers.

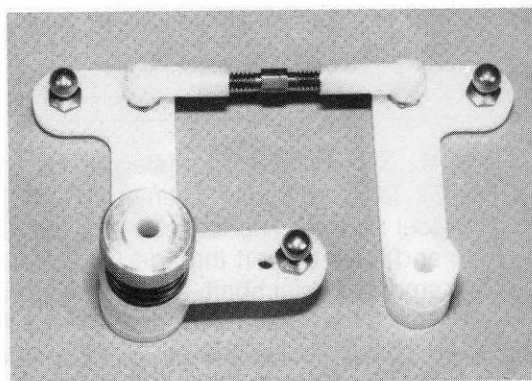

Fig. 27

Fig. 28 Slip the servo saver assembly down onto the two long screws and screw on the two 4-40 nylon nuts. Screw the nuts down just enough so that there isn't any excessive up and down play in the servo saver, but NOT TOO TIGHT. The servo saver arms should be free to swing to the left and right VERY FREELY. The servo saver arms should be parallel.

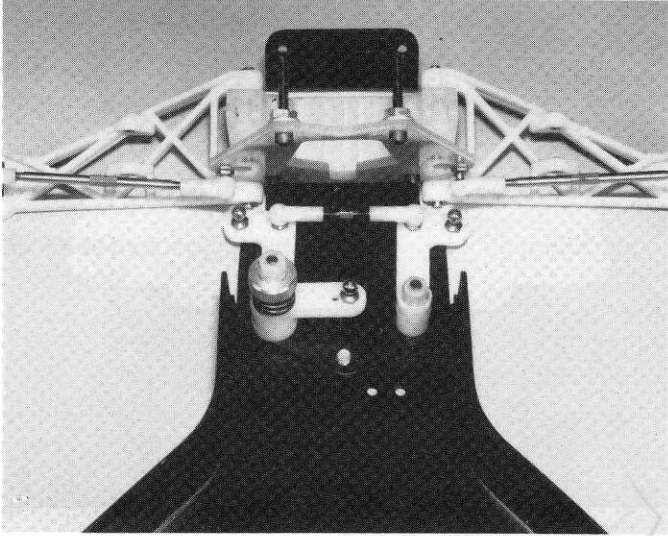

Fig. 28

Figs. 29 & 30 From Bag 7-4 remove two #7315 nose brace tubes and the two short 4-40 x 1/4" SHCS and two long 4/40 x 1/2" SHCS screws as shown. We want to install the tubes so that the screw holes that are closest to the end of the tubes go towards the front of the car.

Slip the tubes through the holes in the shock strut, and align the tube in the slot in the bulkhead. Install the short screw through the hole in the chassis and the rear hole in the tube. Install the screw, but do not tighten it yet. Install the longer screw through the front bulkhead and tube and tighten, but do not over-tighten the screw. Tighten the rear screw. Do both tubes.

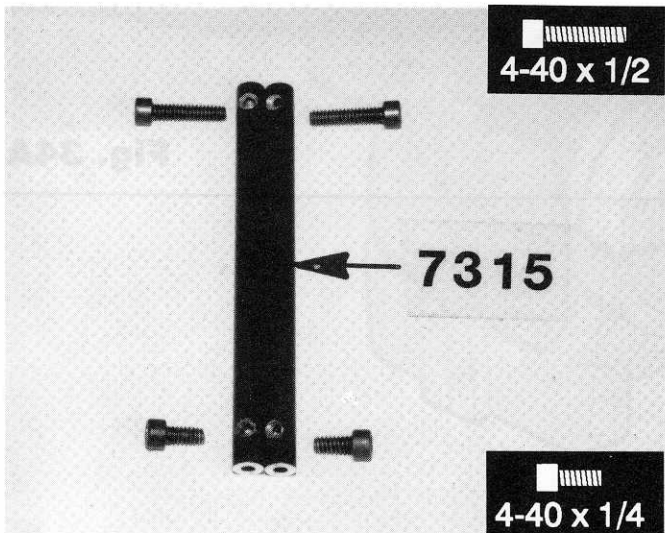

Fig. 29

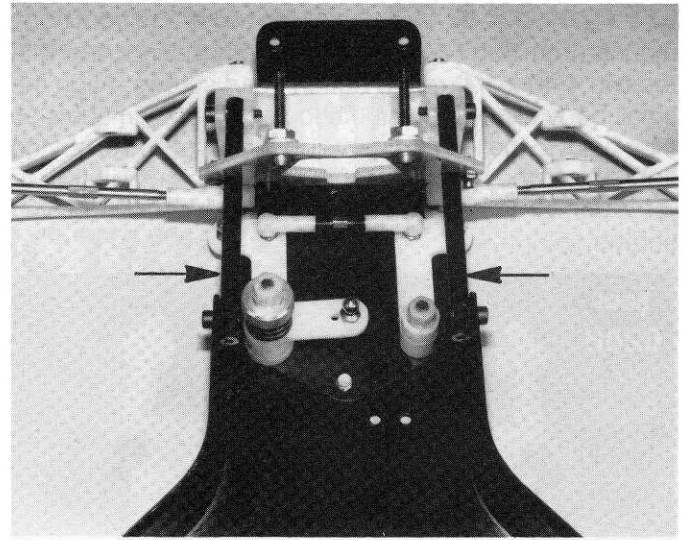

Fig. 30

Fig. 31 Using a pliers, install both of the longer tie rod turnbuckles as shown. If you move the servo saver to the left and right it will be easier.

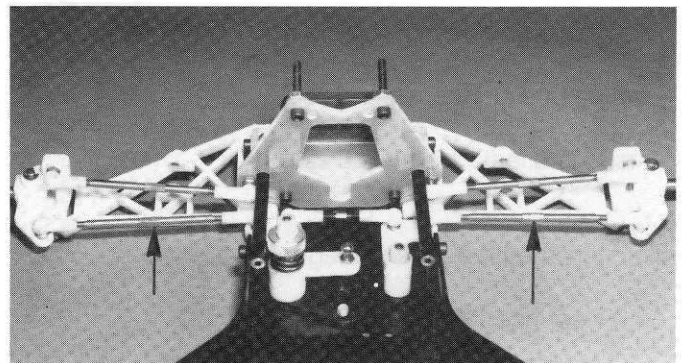

Fig. 31

□ **Figs. 32 & 33** Install the two #7319 front body mounts (from Bag 7-5) to the #7318 body mount brace with the two 4-40 x 1/4" round button head screws. Align the small body clip holes in the ends of the body mounts so they point to the left and right. Tighten screws, but not too tight. Install the brace onto the front bulkhead with two 4-40 x 3/8" SHCS screws as shown. Do not overtighten screws.

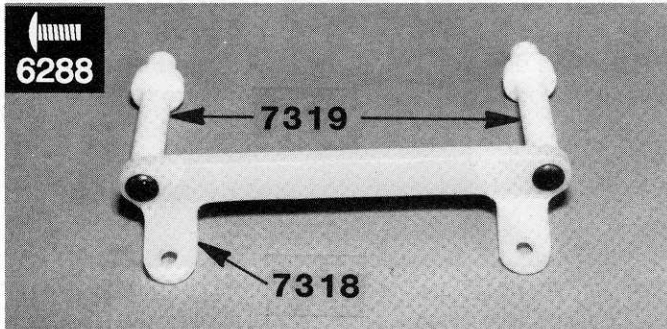

Fig. 32

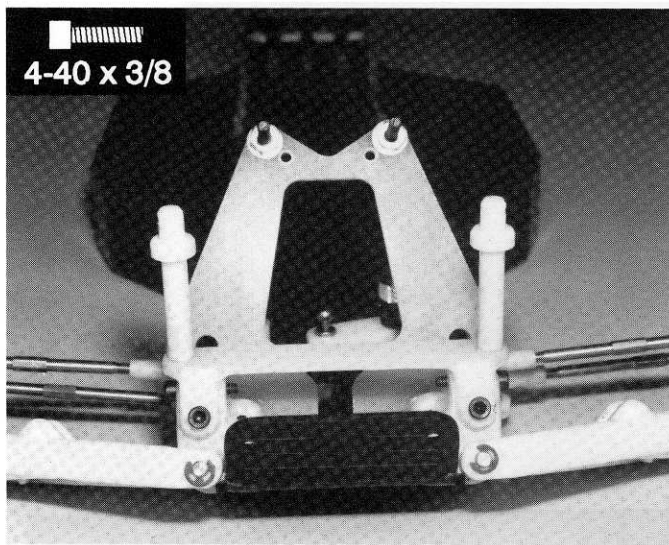

Fig. 33

□ **Figs. 34 & 34a** Install the #7324 front bumper to the chassis nose, as shown, using two #6291 4-40 x 1/4" flat head screws and #7260 4-40 thin plain nuts. You may have to trim a little off the bumper to make sure the A-arms clear.

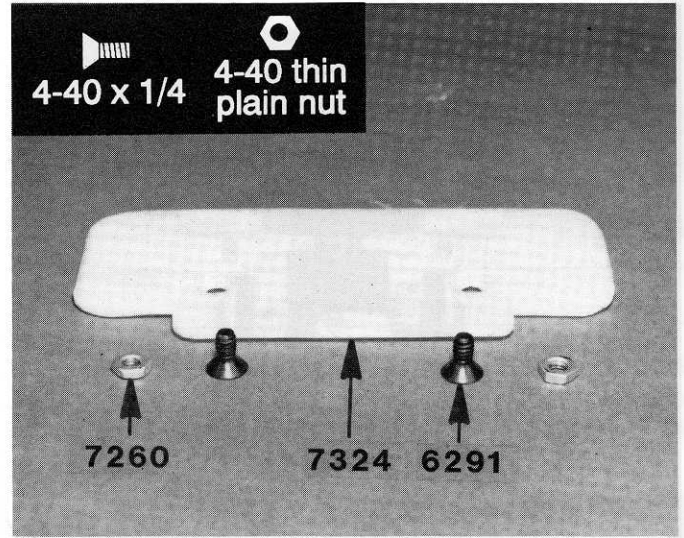

Fig. 34

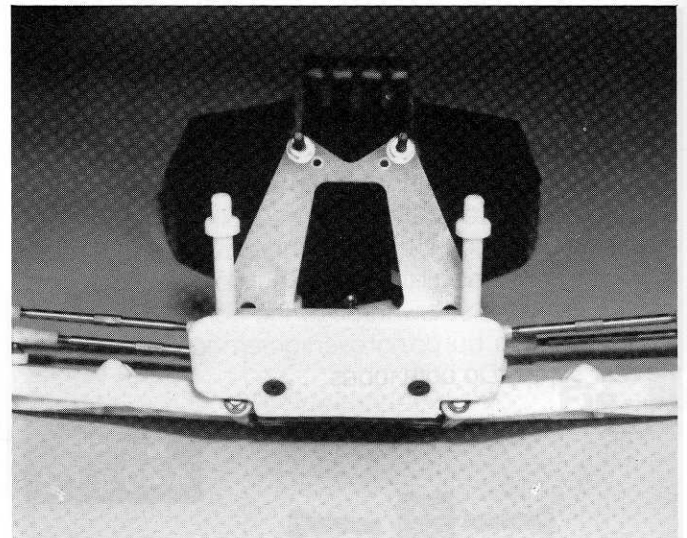

Fig. 34A

TEAM ASSOCIATED
STEALTH
with ATC TRANSMISSION

Transmission
for the **RC10T**

INSTRUCTIONS

Featuring:

Quick-change spur gear

Case-to-motor plate dirt-proof seal

Lightweight design

Long-life clutch friction plate

Large area/high torque clutch plates

Low inertia drive train

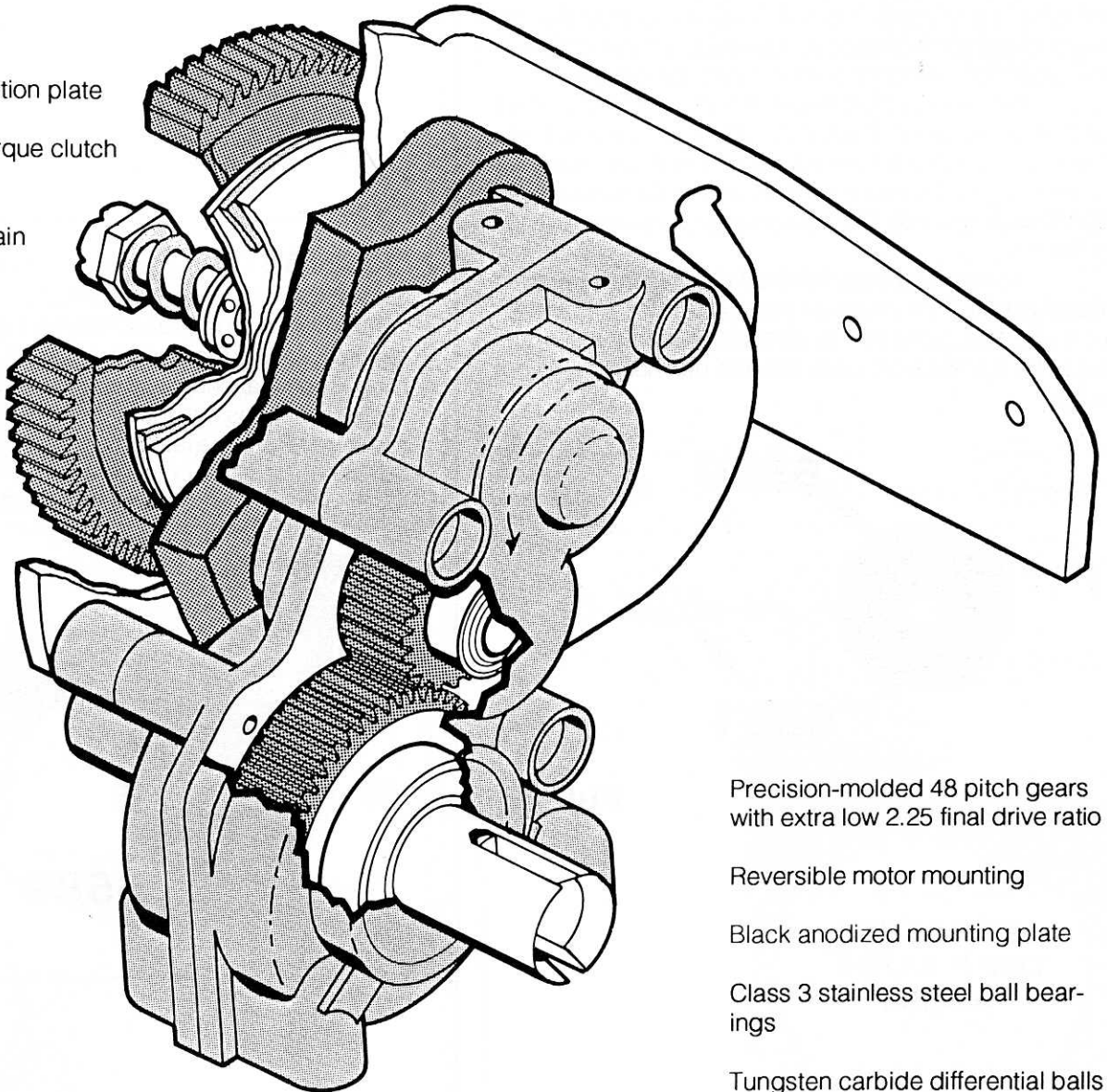

Precision-molded 48 pitch gears with extra low 2.25 final drive ratio

Reversible motor mounting

Black anodized mounting plate

Class 3 stainless steel ball bearings

Tungsten carbide differential balls

Teflon sealed ball bearings

High torque ball differential

STEALTH TRANSMISSION

We feel this transmission is the best in the world. It has enabled Team Associated to finish 1st, 2nd and 3rd at the World Championships in Australia and 1st, 2nd and 3rd at the ROAR Nationals in Northern California with our RC10 car. With this transmission your RC10T will be much easier to drive, enabling you to cut your lap times by a considerable amount. But it all depends, of course, on how well you assemble and maintain your transmission. So take your time and do it to the best of your ability.

Figs. 35 & 36 Look for the bag with the #6604 black motor plate as shown in Fig. 68. From there, remove Bag A and take out the #6580 diff gear and the bag with the 12 large #6581 3\32" carbide diff balls. These carbide diff balls are the best there is. They will outlast the diff washers at least 10 times. NEVER replace these balls with any other balls except our #6581 carbide diff balls.

Now take out the #6591 Stealth white silicone diff lube. Another word of caution. DO NOT substitute any other type of diff lube on the balls. It took us countless hours of testing to find the correct silicone diff lube to make the diff work correctly. Do yourself a favor: use what comes in this kit!

Trim any excess flash off the inside of the gear bearing hole. Fill the holes in the gear with the silicone diff lube and then push the 12 carbide balls into the holes. Wipe the excess lube back into the ball holes with your finger.

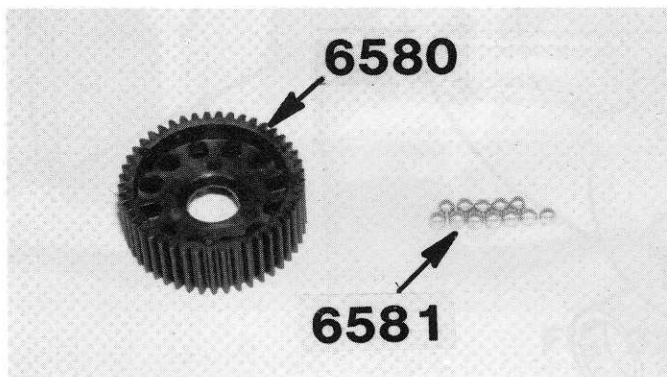

Fig. 35



Fig. 36

Fig. 37 Your gear.

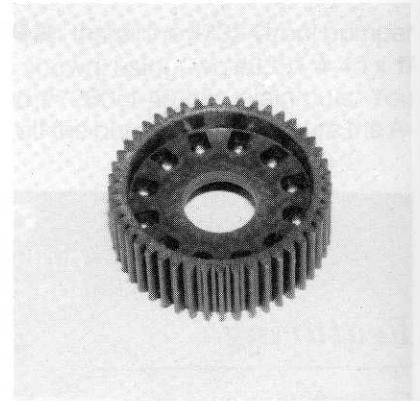

Fig. 37

Fig. 38 Clean all the silicone grease off your hands. Next open Bag B which contains the nine bearings for the tranny. Take out the three small bearings with 5/16" outside diameter and lay them on a flat surface. If you look carefully you will see that one has a slightly larger inside diameter. The two bearings with the small inside diameter are #6589 and the one with the larger I.D. is a #6901. Push one of the #6589 ball bearings onto the center of the gear. The other #6589 bearing goes onto the #6578 left hand hub from Bag A as shown.

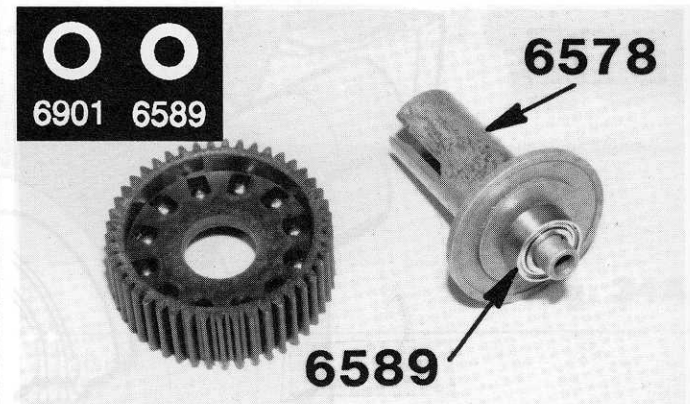

Fig. 38

□ **Fig. 39** Your completed gear.



Fig. 39

□ **Fig. 42** Take an Exacto knife and trim off any of the plastic T-nut that extends outside of the slot, as shown.

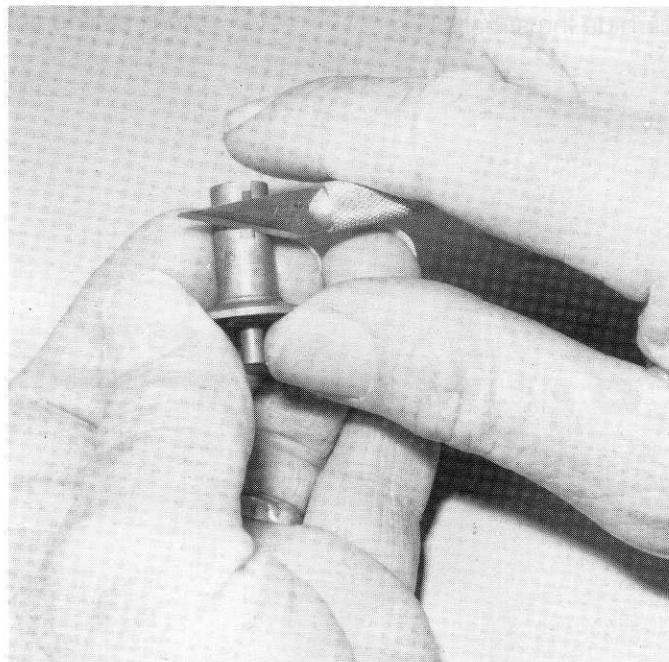

Fig. 42

□ **Figs. 40 & 41** Using the #6578 left diff outdrive hub again. Remove the #6589 bearing and set it aside for a moment. **Make sure the hub is clean and free from all burrs.** Push the #6582 diff thrust spring into the hub and then align the plastic T-nut with the slots in the hub and push the T-nut all the way in against the spring.

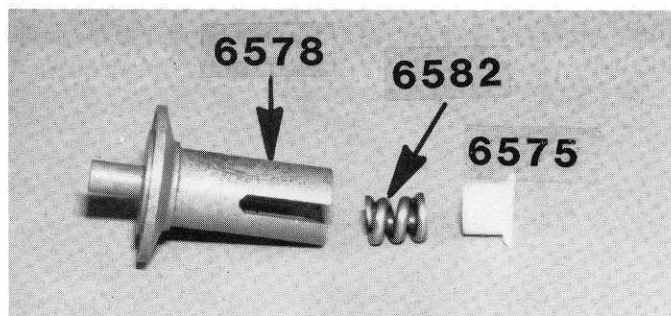

Fig.40

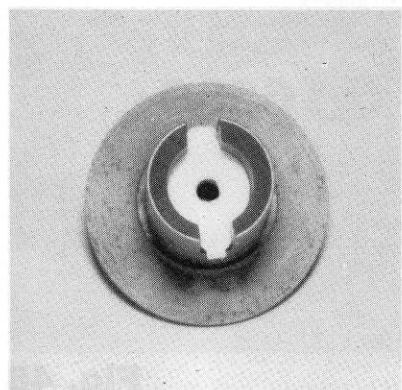

Fig. 41

□ **Fig. 43** There should now be approximately a $3/32$ " or $.100$ " gap where shown.

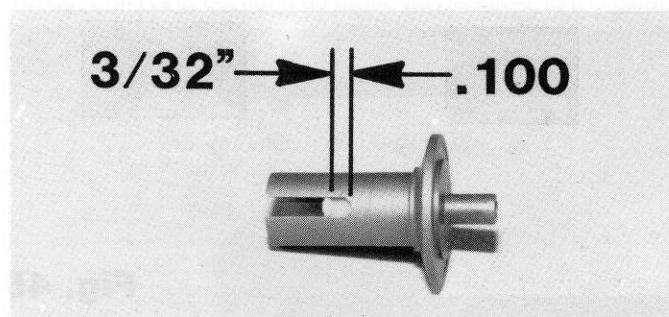

Fig. 43

□ **Fig. 44** From Bag A take out the #6575 diff thrust bolt, the two #6573 diff thrust washers and the #6576 carbide thrust balls.

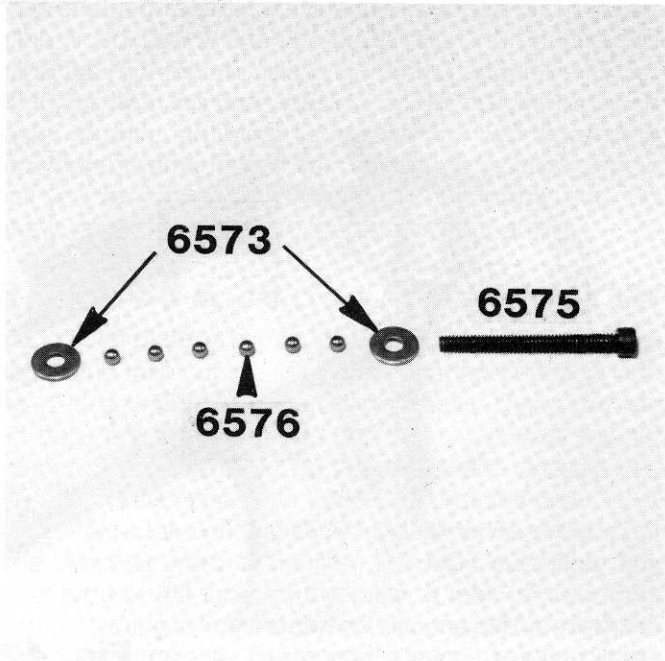

Fig. 44

□ **Figs. 45 & 46** Slip the two washers on the bolt, as shown, and then fill the area between them with the #6588 black grease. DO NOT use the black grease on the diff balls in the gear.

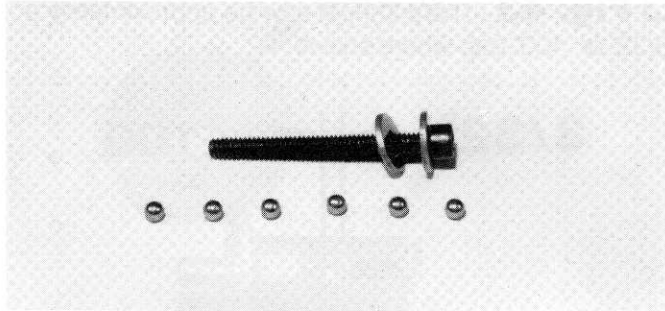

Fig. 45



Fig. 46

□ **Fig. 47** Now take the balls and place them all around the bolt between the two washers. The grease will hold them in place.

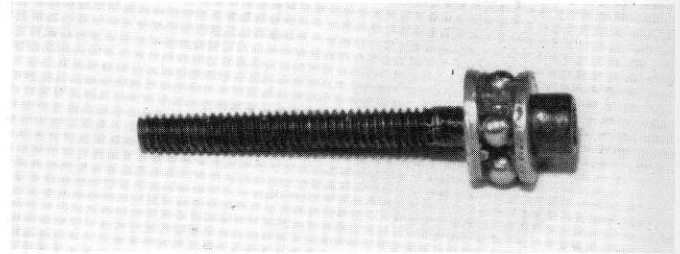

Fig. 47

□ **Fig. 48** Take the #6577 right hand diff outdrive hub, make sure it's clean and free of all burrs, and put the other #6589 ball bearings into the hub. The ball bearings must go in with a simple push of your finger. **NEVER drive them in!** Now place one of the #6579 diff drive rings onto the hub.

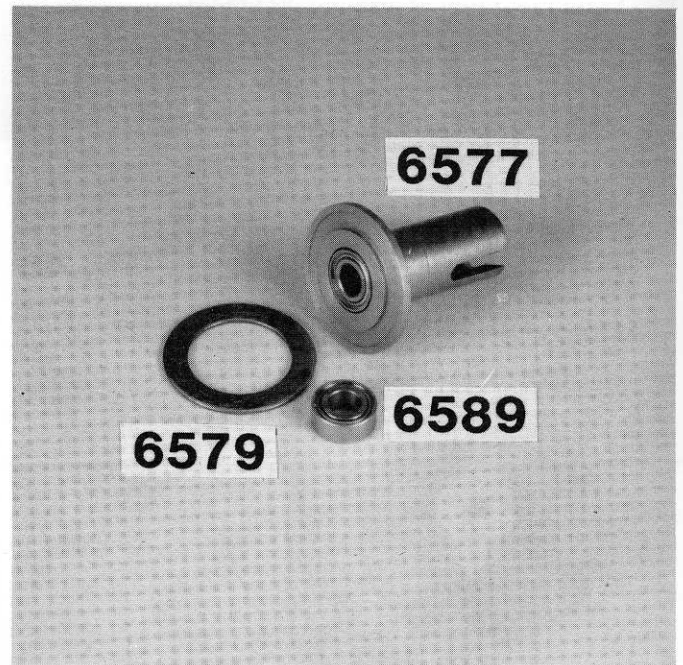

Fig. 48

Fig. 49 Your hub should look like this. DO NOT try to pin the drive ring to the hub. The hub is designed to lock the drive ring without pinning. Leave AS IS.



Fig. 49

Fig. 51 Turn the assembly upright. Make sure the drive ring is still ON and centered. Slip the diff gear onto the bolt as shown.

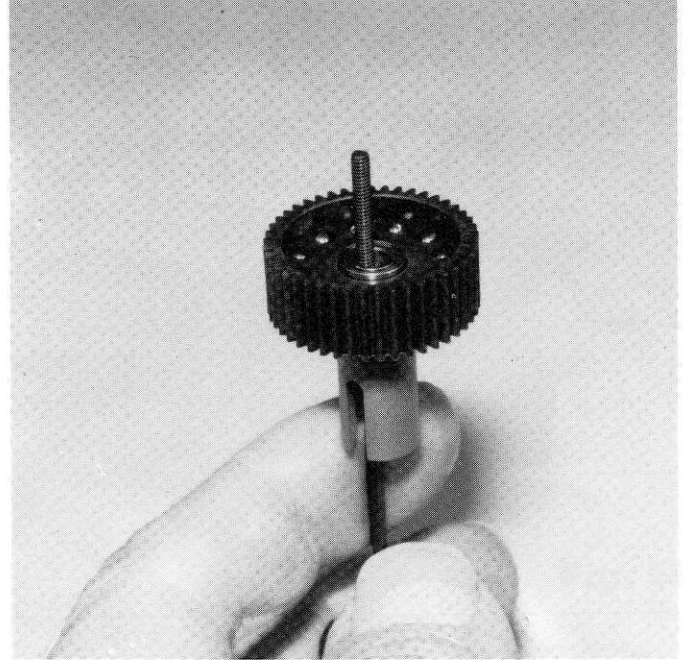

Fig. 51

Fig. 50 Slip the 5/64" Allen wrench from the separate unlabelled wrench bag into the bolt head and then slip the assembly into and through the right hand hub.

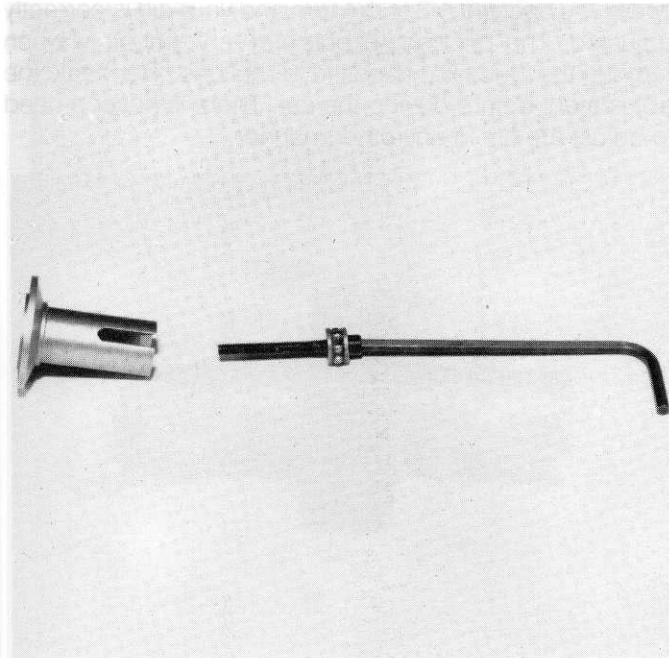

Fig.50

Fig. 52 Now place the other #6579 drive ring onto the diff balls and center it as close as possible to the gear.

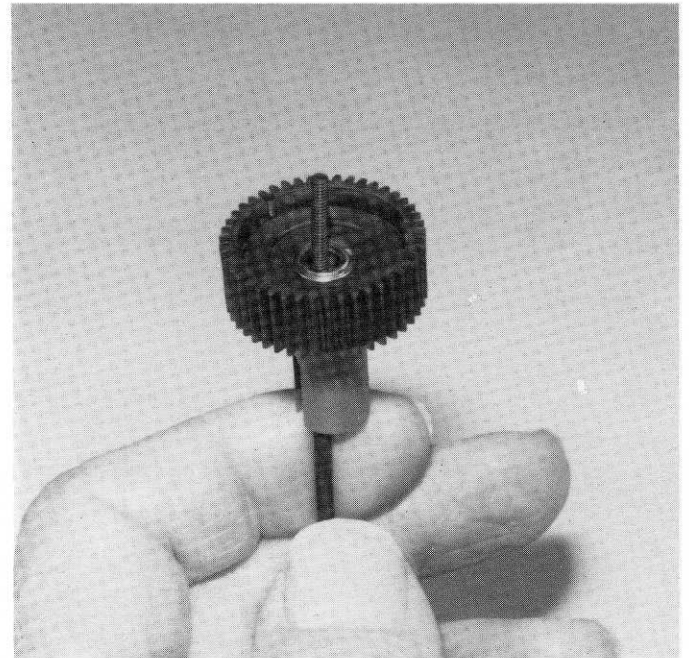

Fig. 52

□ **Figs. 53 & 54** Slip the #6577 left hand hub down onto the bolt, making sure the hub centers itself onto the drive rings. THIS IS IMPORTANT.

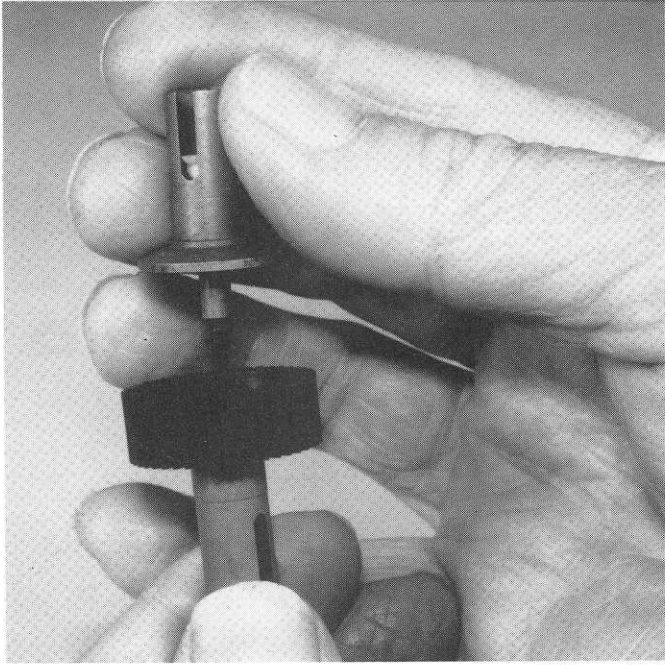

Fig. 53

□ **Fig. 54** Now start to tighten the bolt with the Allen wrench, making sure the hubs and drive rings stay centered. Do this very slowly. We want to make sure everything stays centered. We'll finish the tightening in the next step with figs. 55 & 56.

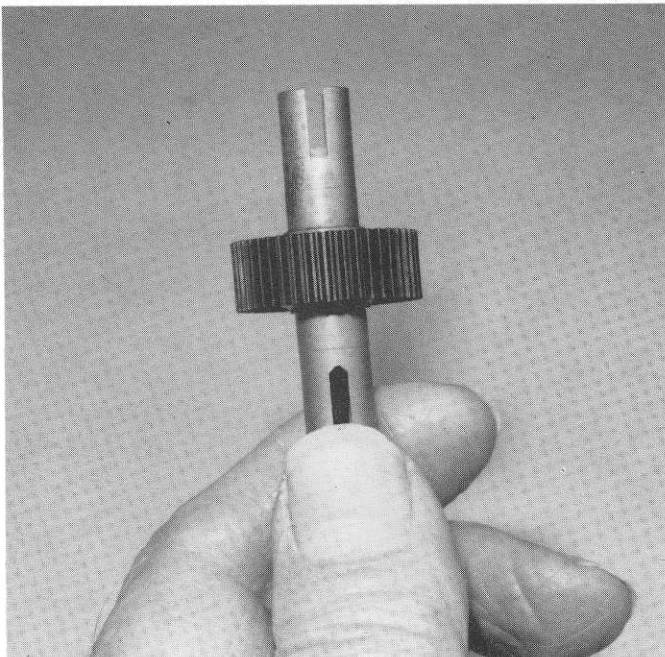

Fig. 54

□ **Figs. 55 & 56** Continue tightening slowly until the spring is just about completely collapsed. DON'T OVER-TIGHTEN! Correct adjustment is bottoming the spring and then backing off 1/8 to 1/4 turn.

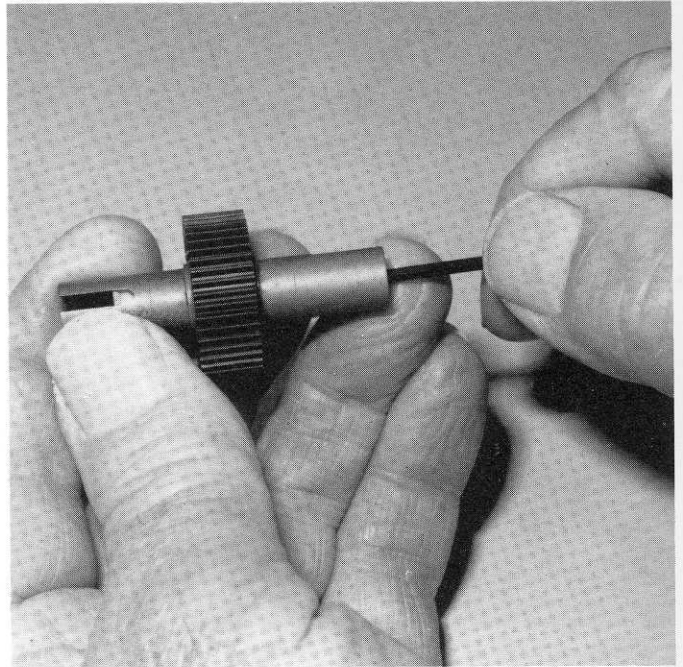

Fig. 55

□ **Fig. 56** As you're tightening, you'll notice the ear on the T-nut, shown by the arrow, moving closer and closer to the bottom of the slot in the hub. The spring should bottom out about the same time as the ear is at the bottom of the slot. When you feel the spring bottom out, that's when you back off 1/8 to 1/4 turn and your diff is correctly adjusted. The diff should operate very smoothly when turning the hubs in opposite directions. Recheck the adjustment before driving the car. There is never a need to adjust the diff in any other manner.

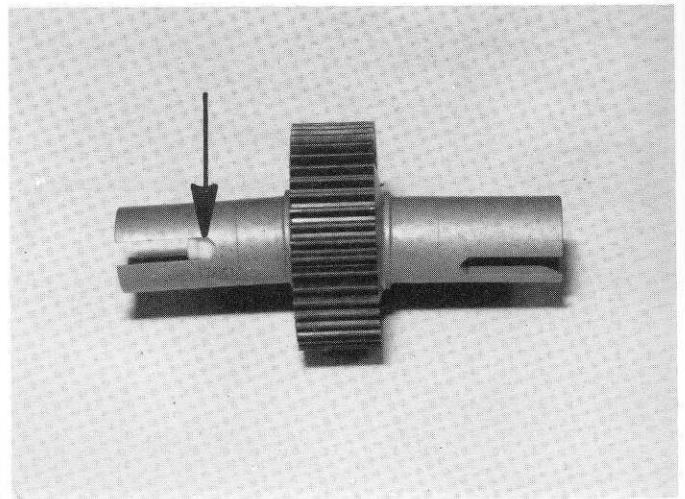

Fig. 56

□ **Fig. 57** Open Bag C and remove the #6565 left and right hand transmission cases (tranny cases), and remove any flash left from molding. Then install the four #6906 upper and two #6903 lower bearings.

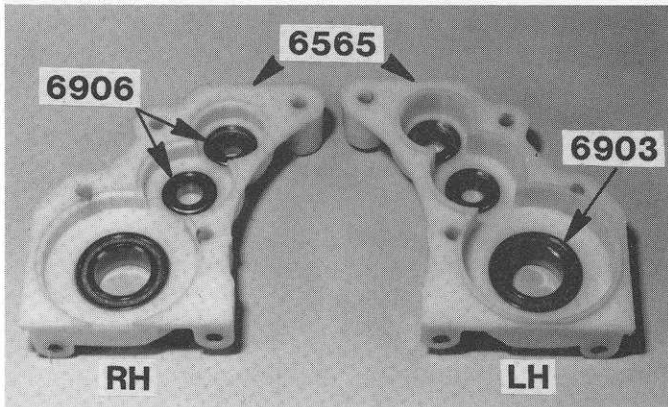

Fig. 57

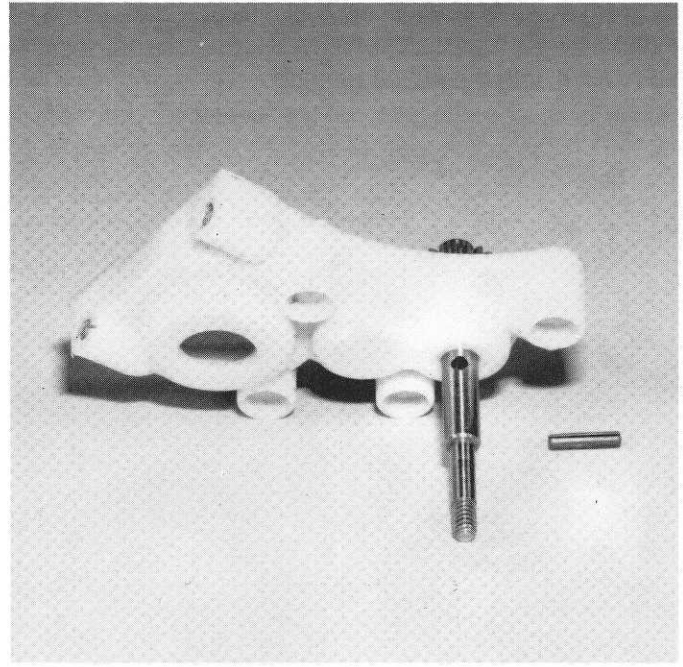

Fig. 59

□ **Figs. 58 & 59** Open Bag D and remove the #6571 drive gear assembly and slide it into the upper bearing in the right hand gear case.

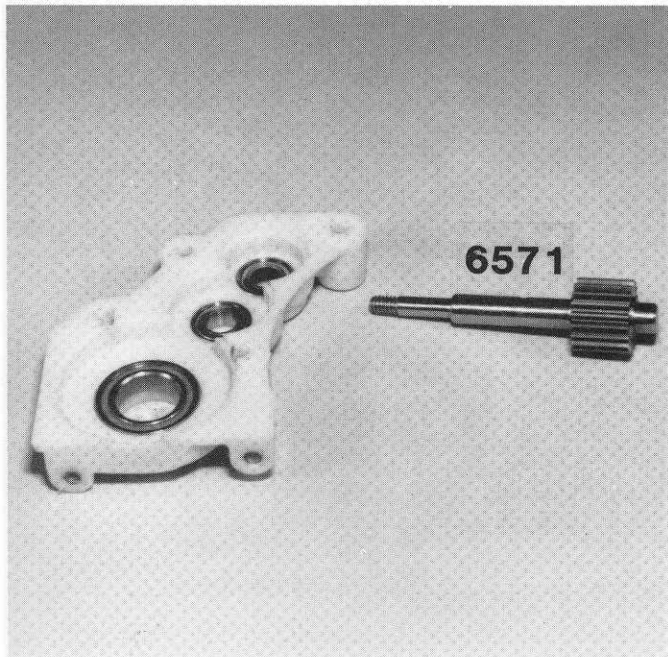

Fig. 58

□ **Fig. 60** Open Bag E and using a pliers, squeeze the roll pin into the hole in the shaft until it is equally spaced.

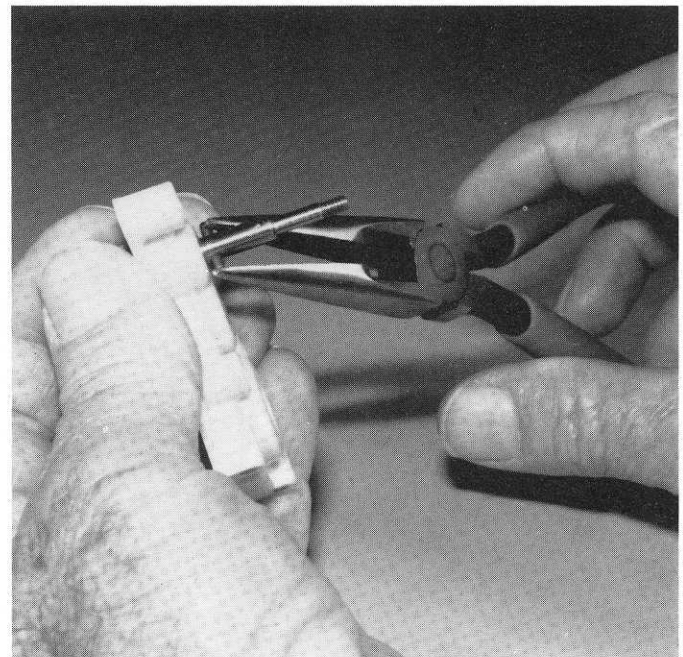

Fig. 60

Figs. 61 & 62 Now take the diff assembly and insert the right hand hub, which is the one that has the bolt HEAD in it, into the #6503 bearing.

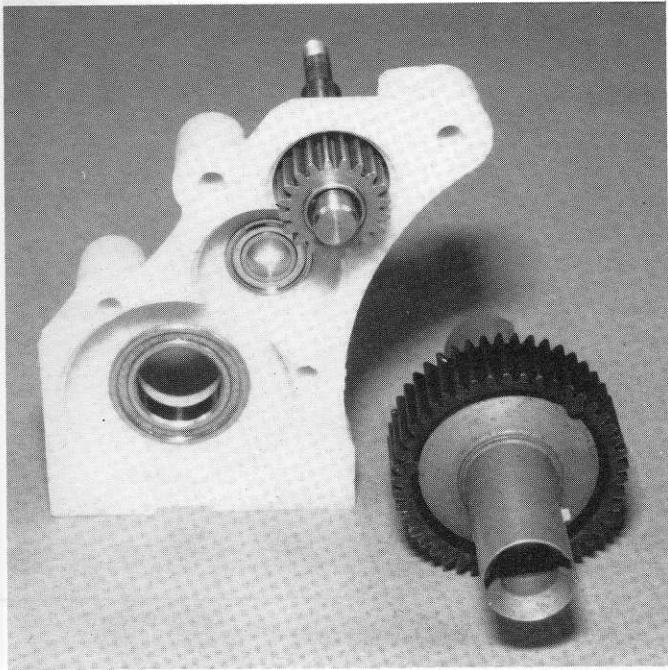

Fig. 61

Fig. 63 Now carefully slip the #6570 idler gear into the center bearing.

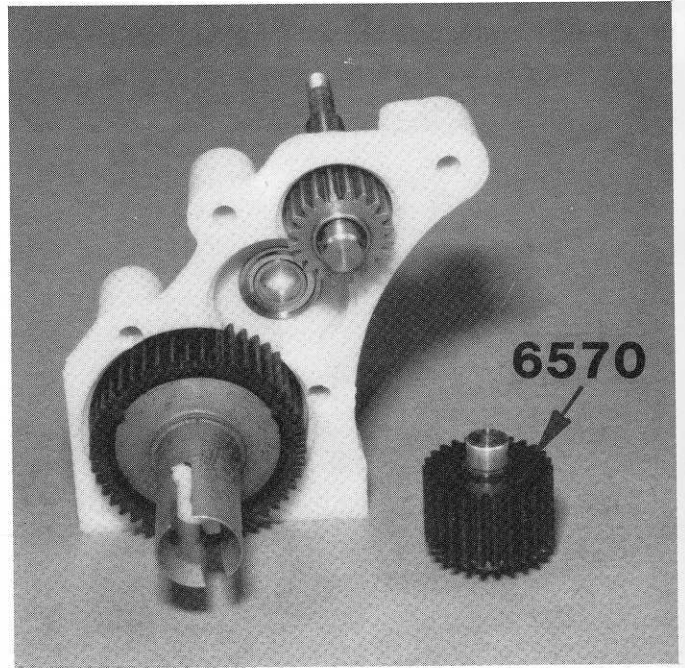

Fig. 63

Fig. 64 The inside of your tranny should look like this. Slip the left hand side of your tranny onto the right hand side.

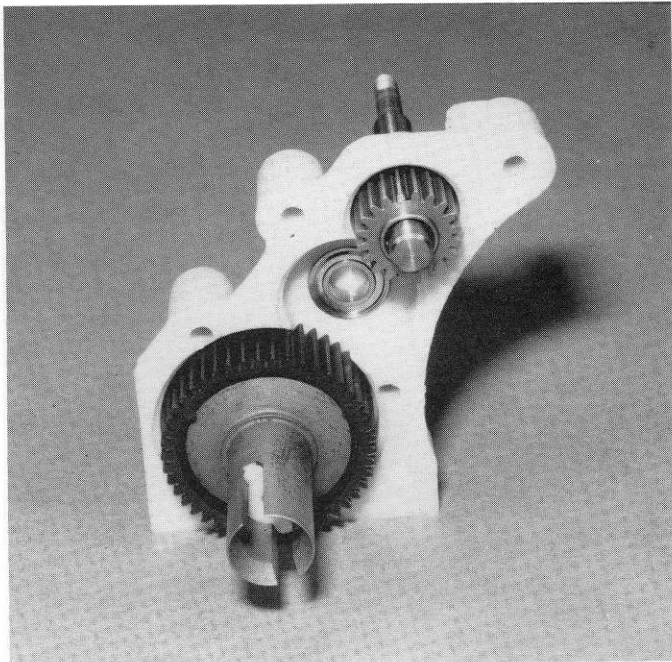

Fig. 62

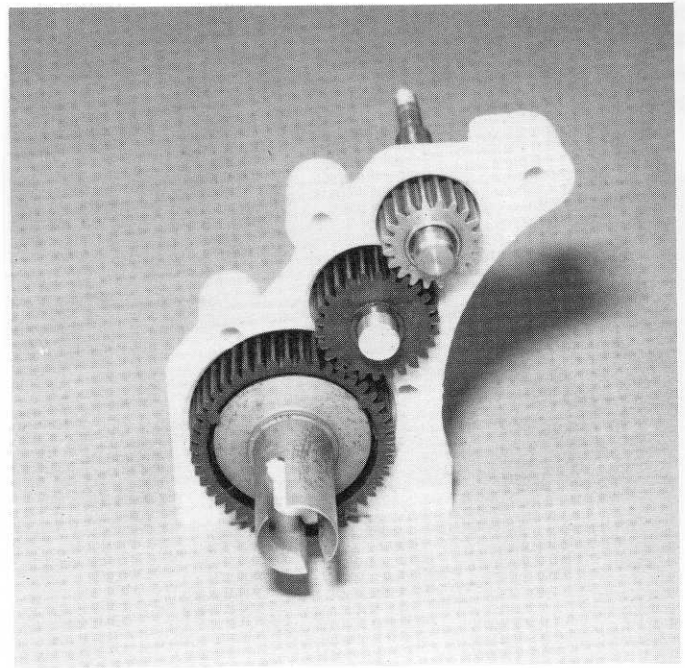

Fig. 64

□ **Fig. 65** From Bag F put the four 4-40 x 1" Allen head case bolts into the case from the left hand side. You'll have to screw them in. Screw in the bolts so they extend about 1/8" on the other side.

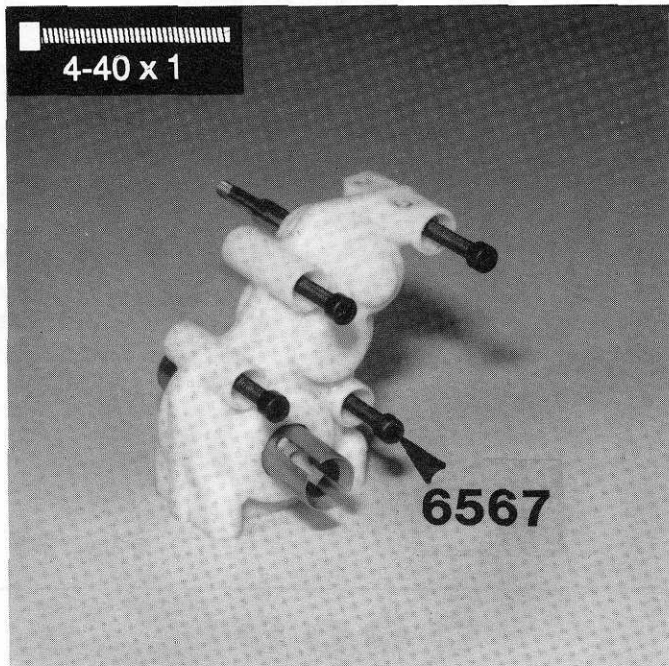

Fig. 65

□ **Fig. 67** Slip the felt dust shield on the three bolts as shown and slip the fourth plastic spacer on the other bolt.

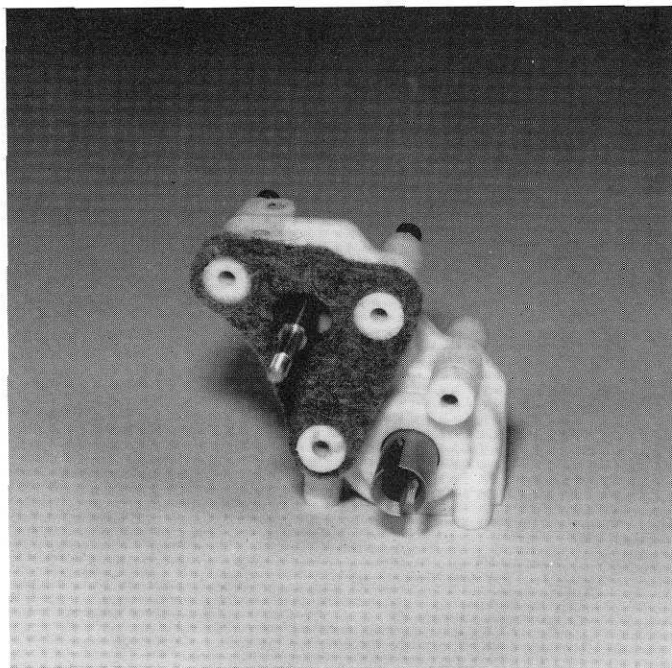

Fig. 67

□ **Fig. 66** Now take the four #6569 plastic spacers from Bag C and slip three of them into the #6566 felt dust shield from Bag F so that the small end of the spacers can go into the case holes.

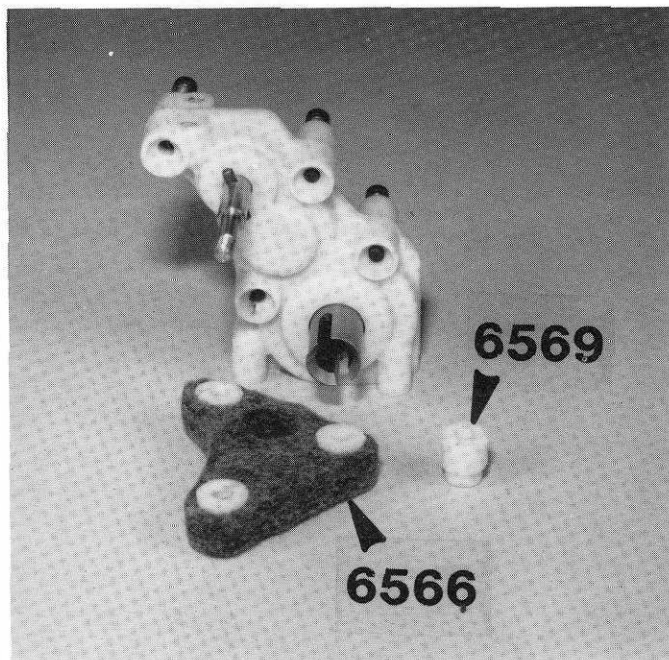

Fig. 66

□ **Fig. 68** Now take the #6604 black motor mount and bolt the tranny to it in the location shown and tighten the four bolts. Then install the small plastic dust cap in the case, where the arrow indicates.

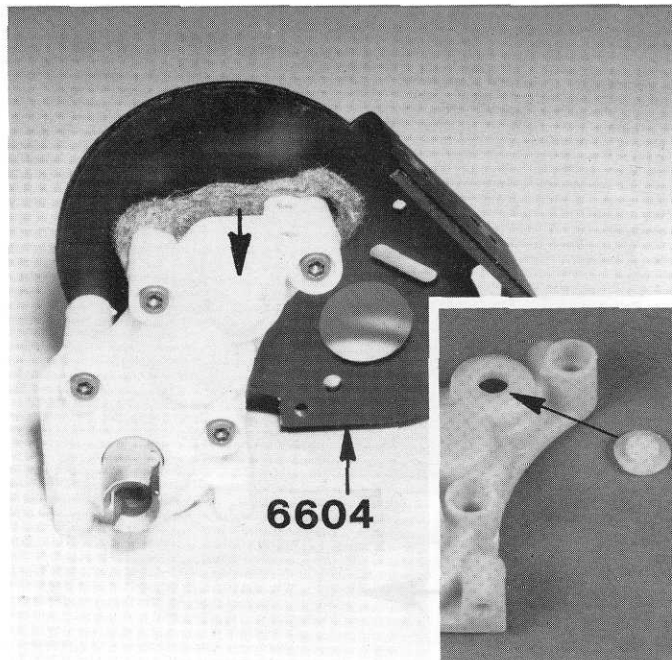

Fig. 68

Fig. 68A

□ **Figs. 69, 70 & 71** Now we'll assemble the clutch Torque Control assembly. Slip the #6583 clutch hub from Bag F onto the shaft, making sure the slots align with the pin.

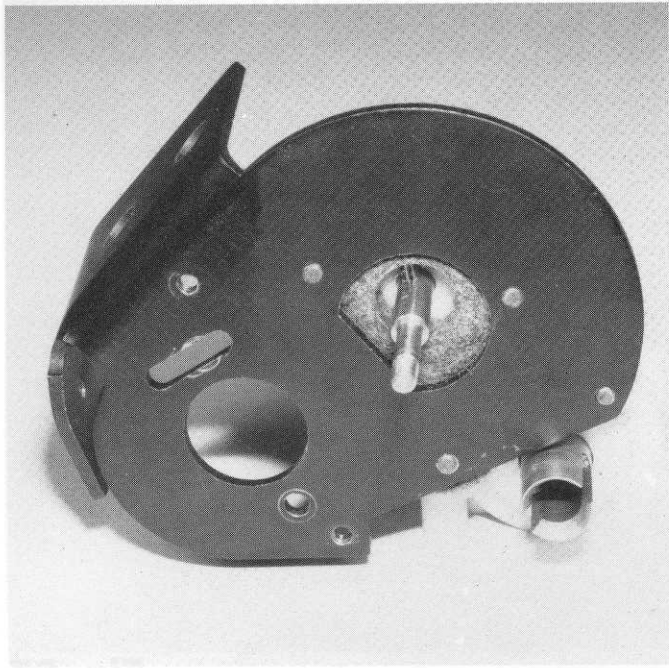

Fig. 69

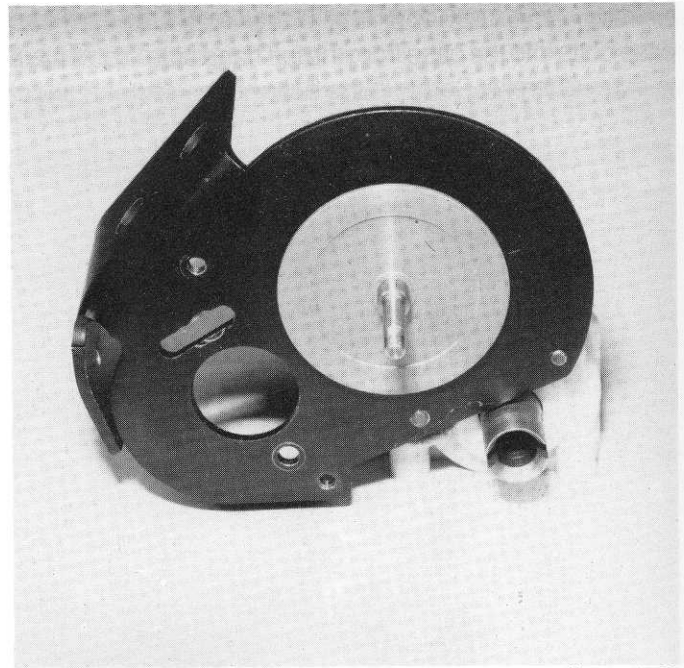

Fig. 71

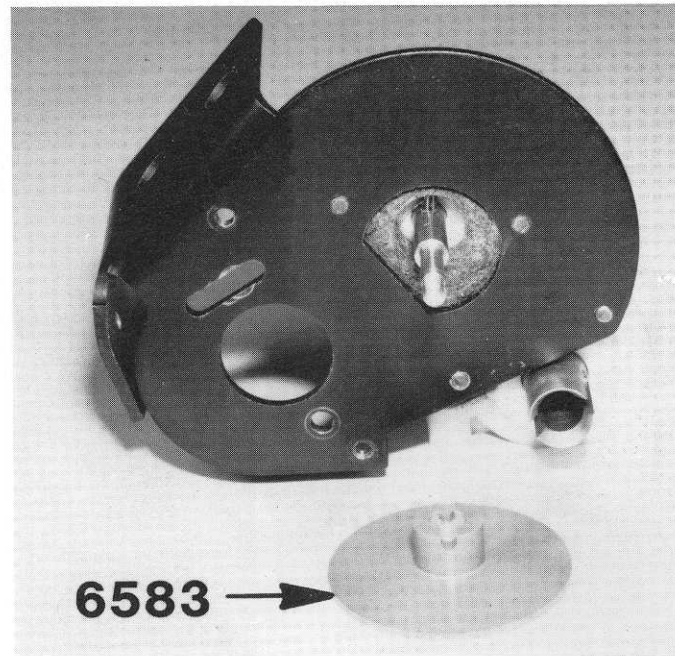

Fig. 70

□ **Figs. 72 & 73** Position the #6585 clutch disk so it's centered onto the #6584 outer hub, as shown.

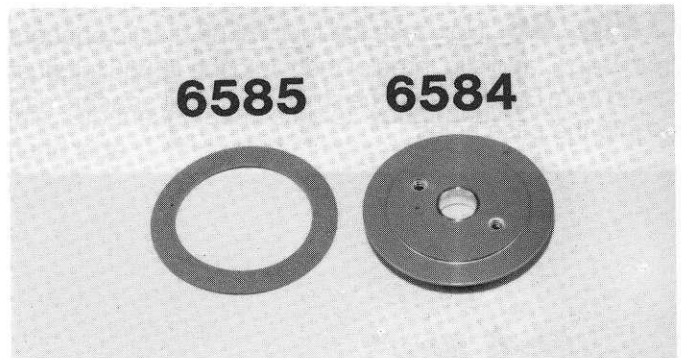

Fig. 72

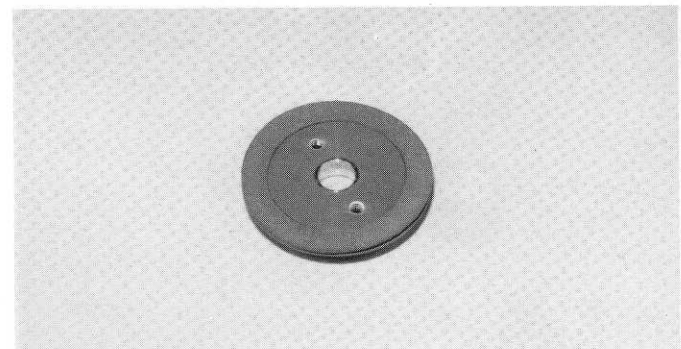

Fig. 73

□ **Fig. 74** Now we'll be assembling these parts, in the order shown, onto the shaft. First, install the #6901 ball bearing from Bag B into the #6584 clutch hub, and then slide the hub onto the shaft, making sure the clutch disk stays centered on the hub.

From Bag F, install one of the #6586 thrust washers, then the thrust bearing and the other thrust washer. (NOTE: when servicing this thrust bearing you can use a **very little** of the #6588 black grease.)

Now slip the #6587 spring on and start the 5-40 nut on. Tighten the nut until about 1/2 thread is showing outside the nut. This is a good starting point for the clutch adjustment. If the ball bearing in the clutch hub will not slip onto the shaft, then you have not used the correct bearing described in fig. 38. Disassemble the diff and install the correct bearing.

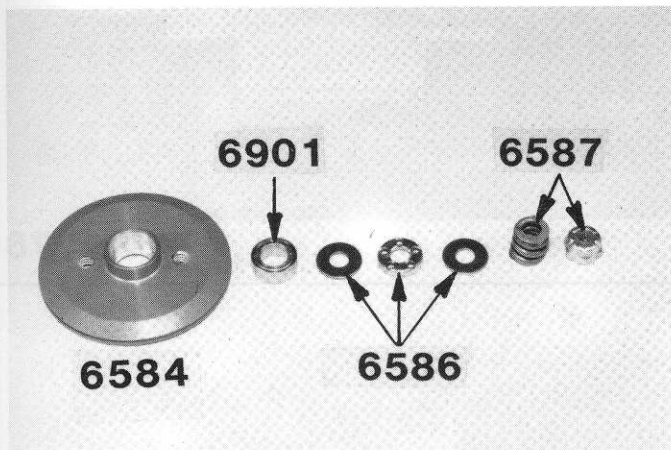

Fig. 74

□ **Figs. 75 & 76** Deburr the center hole and mount the # 6695 87 tooth 48 pitch spur gear from Bag 7-15 with the two #6568 4-40 x 3/16" button head mounting screws from Bag F. NOTE: your #6695 spur gear may be white.

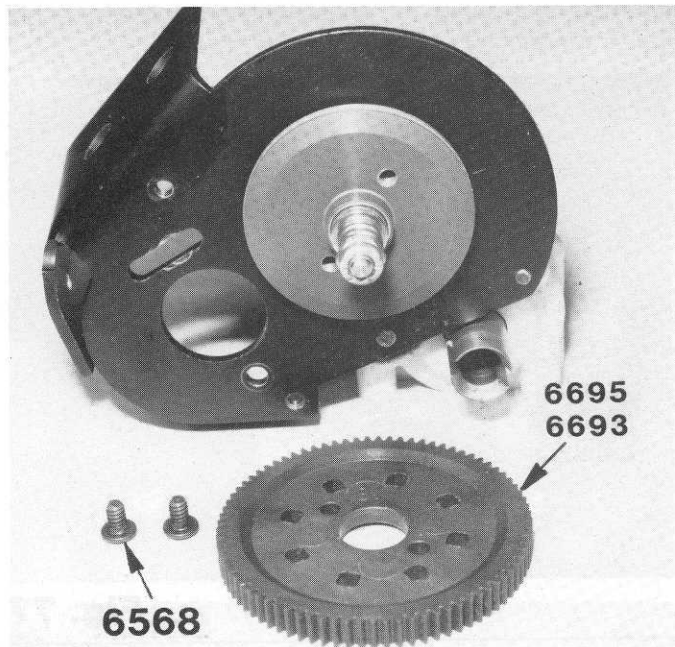

Fig. 75

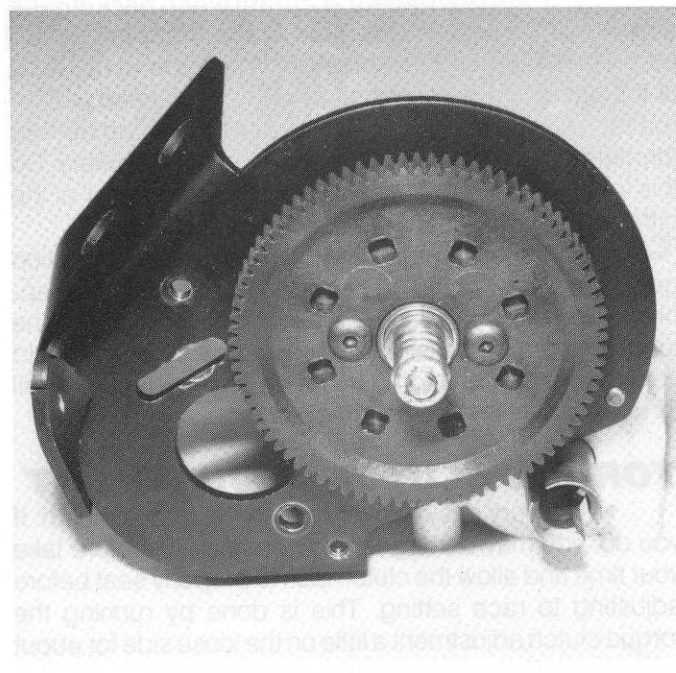

Fig. 76

□ **Fig. 77** From Bag A install one of the thick #6575 nylon washers inside the left hand #6578 outdrive hub, pushing it all the way in. And then install the plastic spacer with the two ears and the 2nd thick nylon washer in the right hand #6577 outdrive hub. The two ears should go all the way to the bottom of the slots and then they can be trimmed off as in fig. 42. These washers and spacer are very important for correct dogbone spacing.

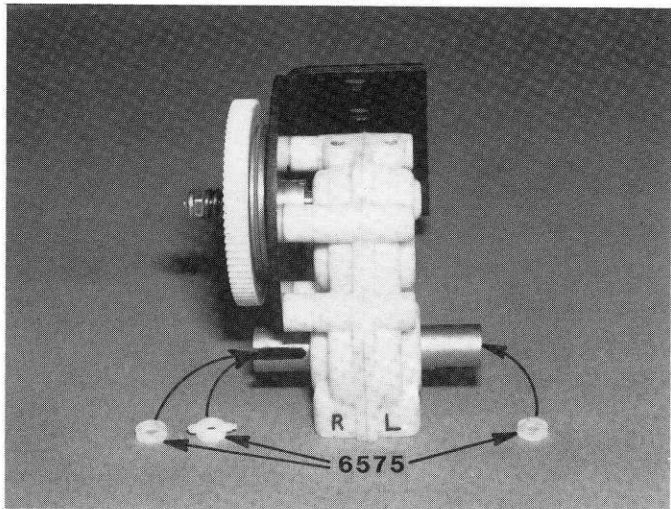

Fig. 77

**CLIFF LETT SAYS:
IMPORTANT-- PLEASE READ**

DIFFERENTIAL ADJUSTMENT

Once the differential has been correctly adjusted there should be no need to change it until rebuilding time. **Be very careful when bottoming the spring during adjustment and extremely accurate when backing the screw out 1/8 to 1/4 turn. This is the most important adjustment in the transmission.** When you've made all of the necessary adjustments and the car is ready to run (battery and motor included), apply a small amount of throttle while holding one of the rear wheels stationary. Do this for about 15 seconds. This will correctly seat all of the differential parts. Now re-check the diff adjustment.

You should rebuild the differential when the action gets somewhat "gritty" feeling. Usually cleaning and applying new diff lube will bring it back to new condition. The tungsten carbide balls (which are standard parts) should very rarely need changing. However, the large and small thrust washers should be checked regularly.

TORQUE CLUTCH ADJUSTMENT

It is very easy to over-tighten the torque clutch. If you do, you may damage the differential. Therefore take your time and allow the clutch disk to properly seat before adjusting to race setting. This is done by running the torque clutch adjustment a little on the loose side for about one minute. Remember that the purpose of the clutch is to gain traction, not break the tires loose.

REAR END ASSEMBLY

□ **Fig. 78** Remove the #6323 rear bulkhead from Bag 7-4 and install two #6273 steel ball ends with long threads where shown.

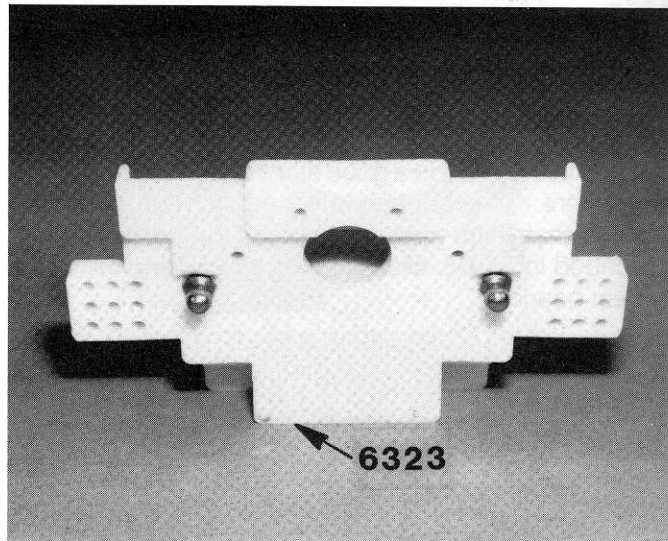

Fig. 78

□ **Figs. 79 & 80** Install the rear bulkhead in the chassis, as shown, with the two #6280 8/32 x 1/2" aluminum screws and two #6925 4/40 x 1/2" SHCS screws. Do not tighten these four screws yet. We need to be able to shift the bulkhead slightly. We tighten the screws later in fig. 85.

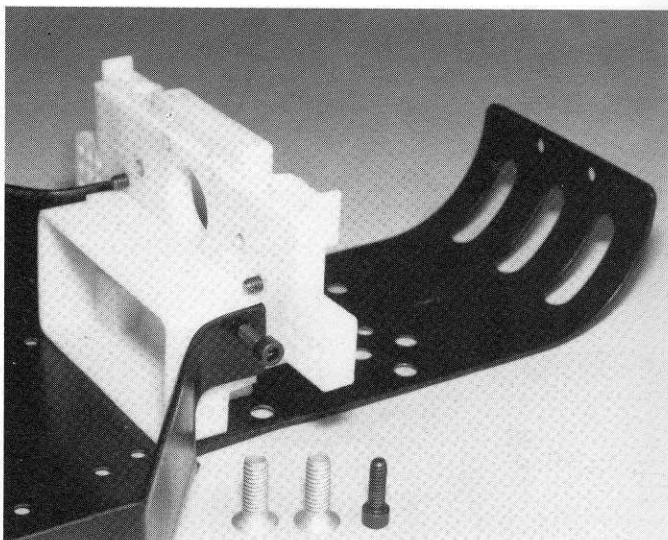

Fig. 79

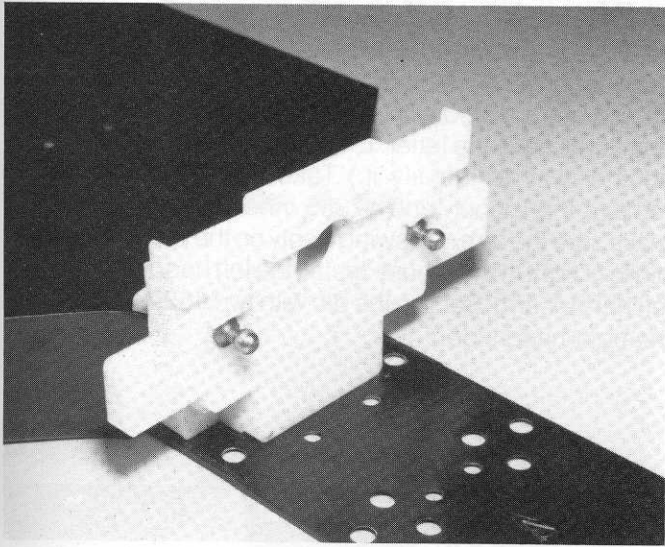

Fig. 80

□ **Figs. 82 & 83** From Bag 7-4, take the #6325 transmission brace and install it on the transmission and rear bulkhead, as shown. Leave the 4-40 x 5/16" SHCS screws fairly loose with the #4 flat washers.

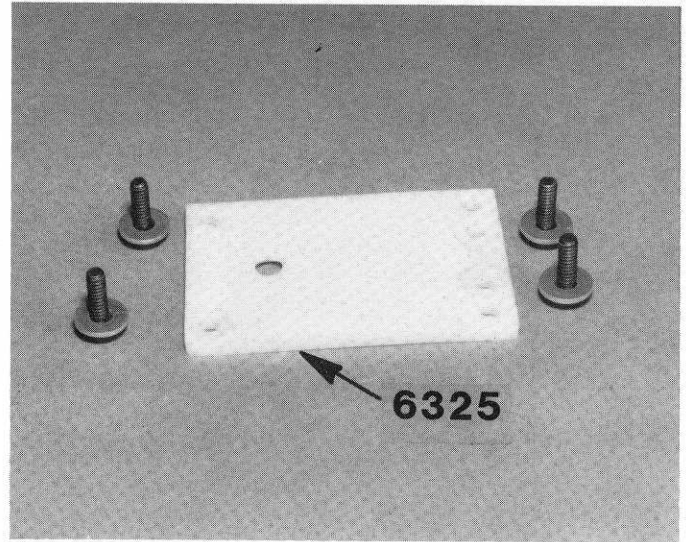

Fig. 82

□ **Fig. 81** Locate the transmission on the chassis, where shown, and install the four #6292 4/40 x 3/8" flat head screws, from Bag F, through the bottom of the chassis into the transmission. Leave the screws very loose; we'll tighten them later.

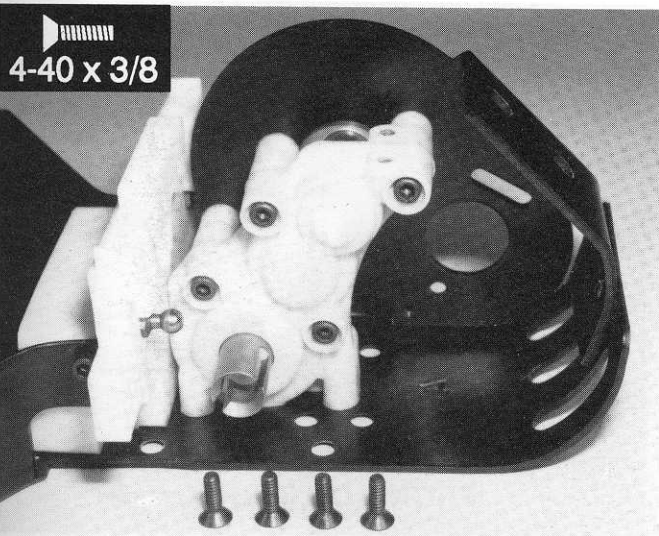

Fig. 81

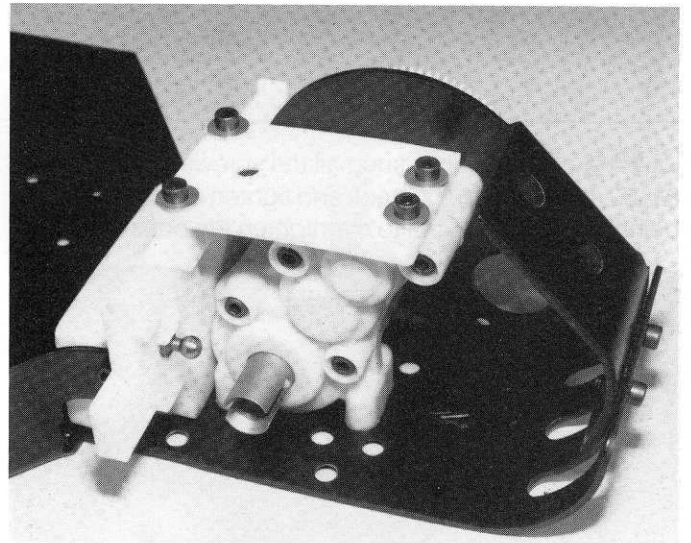

Fig. 83

□ **Fig. 84** From Bag 7-4 install and tighten the two 4/40 x 1/4" SHCS screws in the rear of the chassis and the motor plate, as shown.

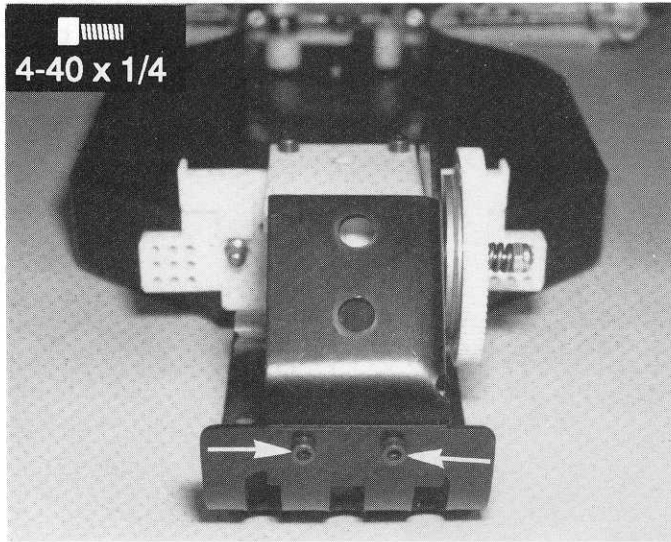

Fig. 84

□ **Fig. 85** Lightly snug all the screws in figs. 79, 80, 81, 82, and 83. Now go back and tighten all those screws, being careful again not to overtighten the ones in plastic.

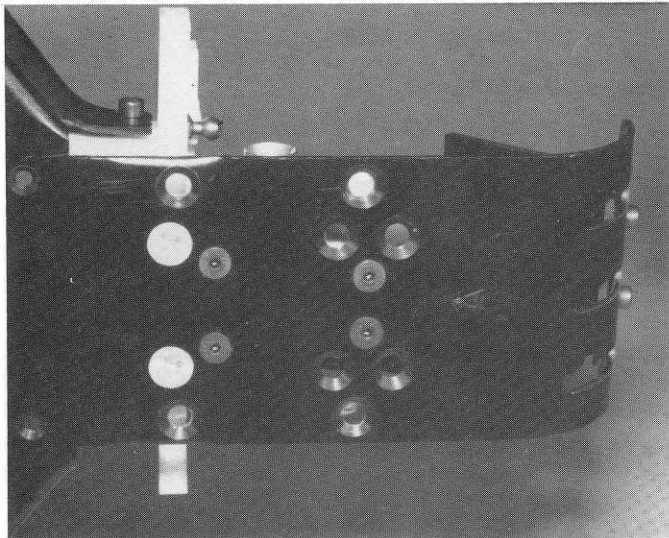

Fig. 85

□ **Figs. 86, 87 & 88** From Bag 7-8 take the #6360 rear suspension mount out. (Note: the left and right rear mounts are attached together by a thin "runner" that should be removed with scissors.) We want the left hand one. It will have the letter "L" on the bottom. (Fig. 87 shows another way to identify it.) Take the #7355 left A-arm, remove the runner, and #7356 inner rear hinge pin and make sure the arm can swing freely on the pin. We want the pin to fit tight in the mount. Install the left hand mount to the left hand A-arm. Secure the pin with two #6299 E-clips. Do the right hand side.

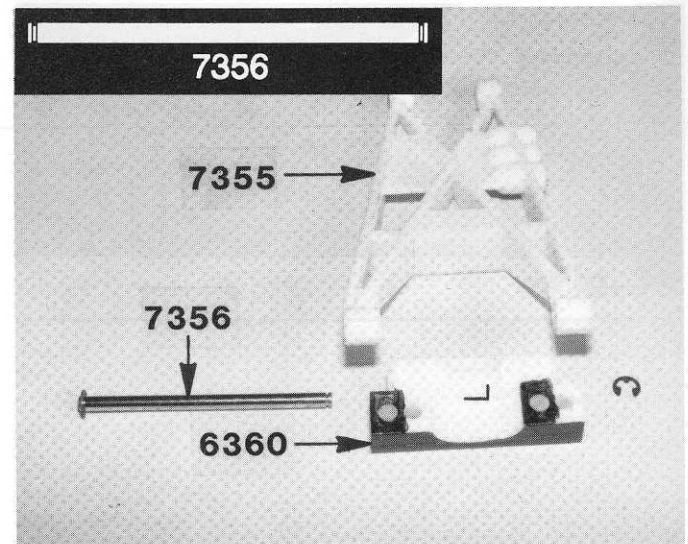

Fig. 86

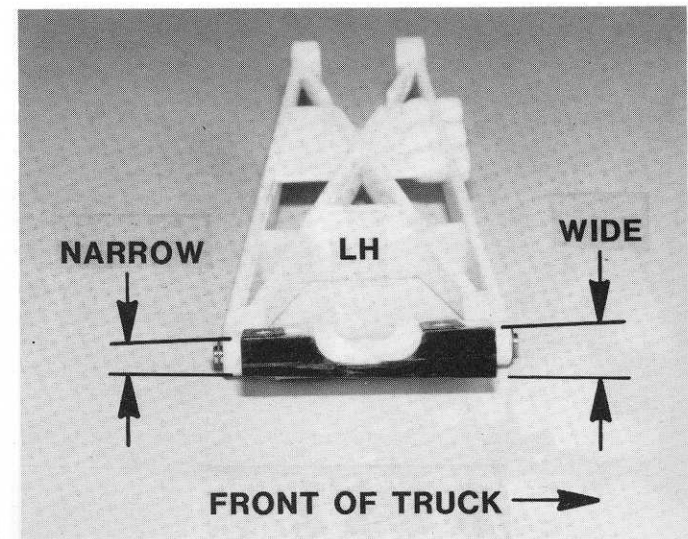

Fig. 87

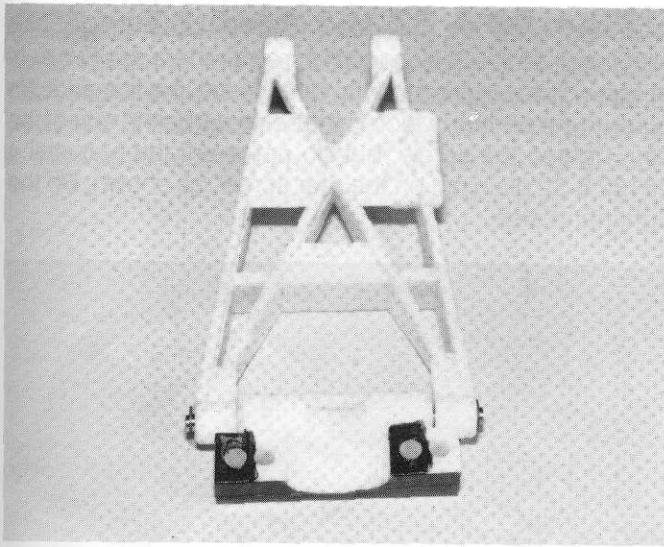

Fig. 88

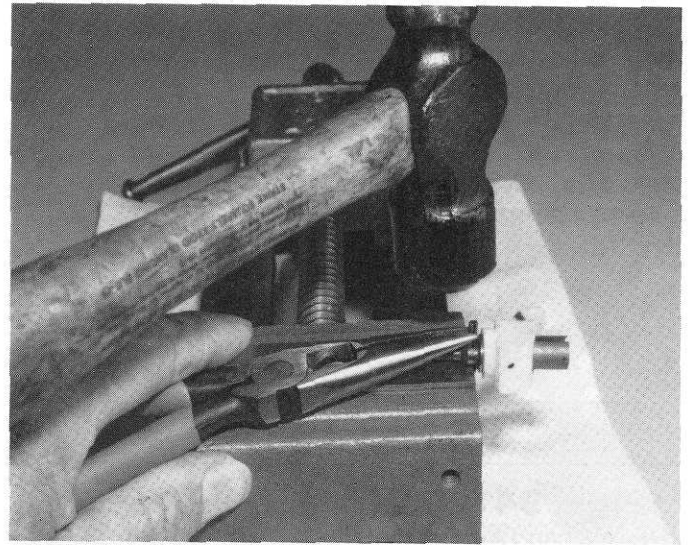

Fig. 90

□ **Figs. 89, 90, 91, & 92** From Bag 7-8, take out the left hand #7358 rear hub carriers. The left rear hub carrier will have an L marked where shown in the photo. Take two #7359 1/4" x 3/8" unflanged ball bearings out of the same bag, and install them into the left rear hub carrier. Seat the bearings all the way in.

Slide the #6374 rear stub axle all the way into the hub carrier from the side shown. Now slip the #6388 tapered washer on, so that the taper on the small diameter is towards the bearing.

Now we want to install the small #6375 split roll pin into the hole in the axle. If you have a vise and a needle-nose pliers, you can install it as shown in fig. 90. Otherwise you can use a pliers to squeeze it into the hole. Make sure the pin is centered in the axle. Do the right hand side.

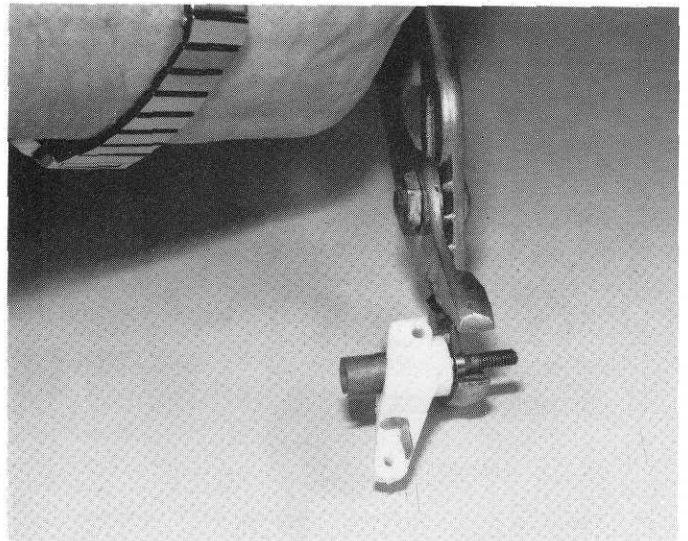

Fig. 91

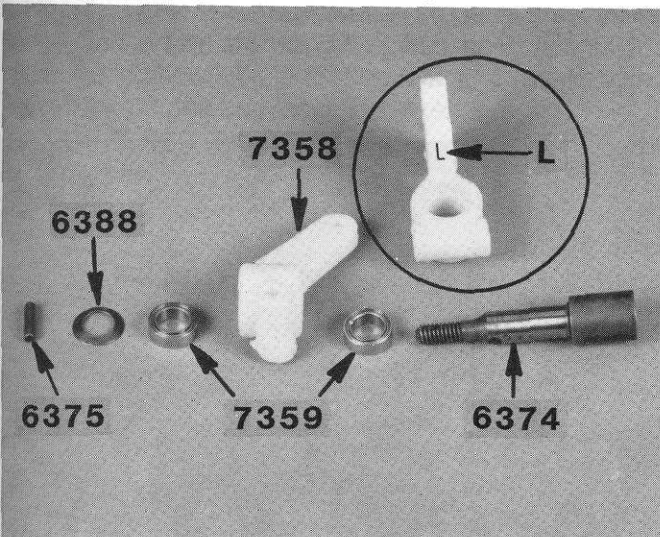

Fig. 89

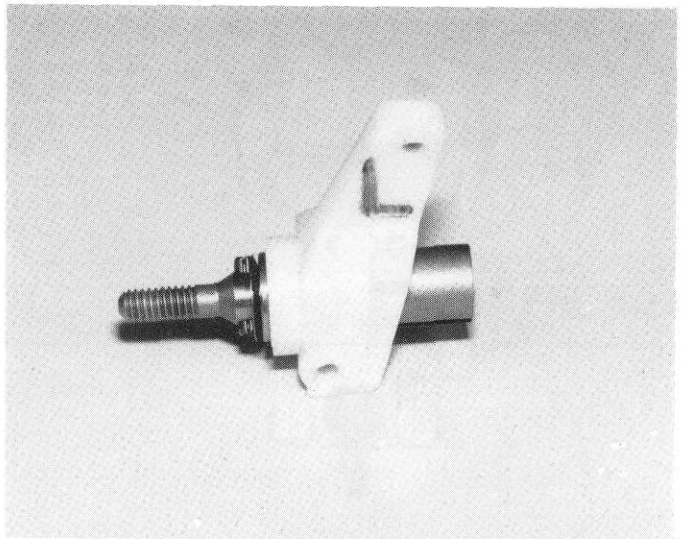

Fig. 92

□ **Fig. 93** Install a #6273 steel ball end with the long threads and a #7260 plain nut, as shown. Do the right hand side, but make sure the ball is facing forward.

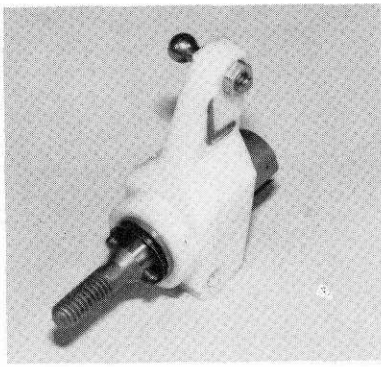

Fig. 93

□ **Figs. 94 & 95** Check the pin fit in the outer hole in the left hand A-arm with the #7357 pin. We want the hole tight in the hub carrier. Assemble the parts and secure with the #6299 E-clips. Do the right hand side.

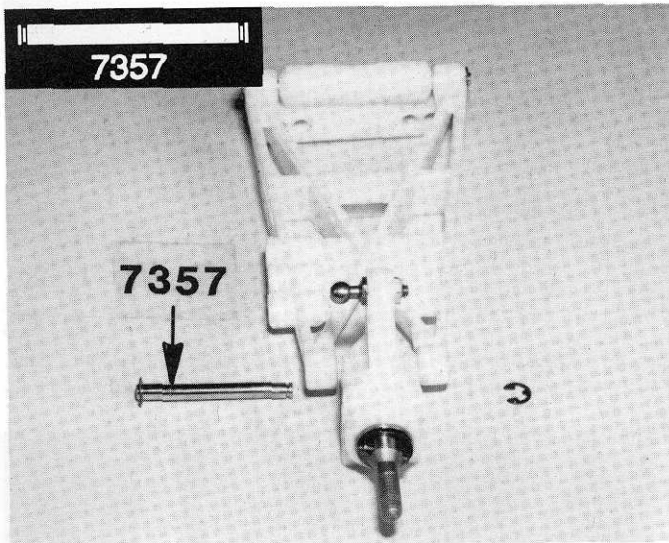

Fig. 94

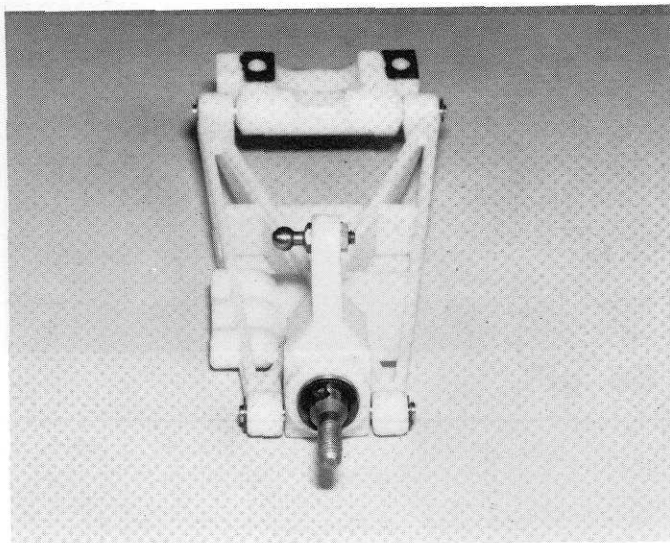

Fig. 95

□ **Figs. 96 & 97** Mount the arms onto the chassis with the 8-32 x 1/2" aluminum screws. There are two sets of screw holes in the mounts. Use the set that is marked in black in the photos, which is the set towards the rear of the car. Tighten the screw, but do not overtighten. Install a #8182 8-32 plain nut on the rear screw, as shown. Do the right hand side.

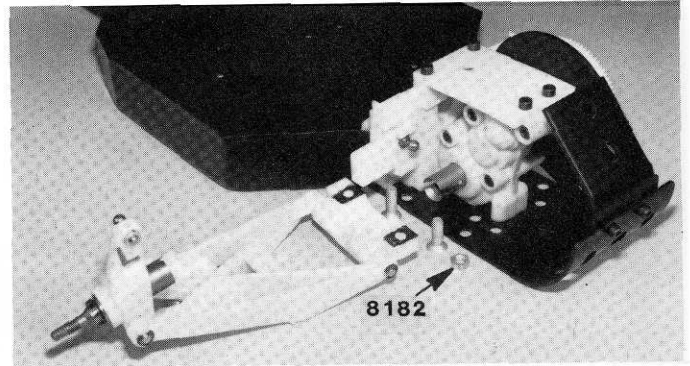

Fig. 96

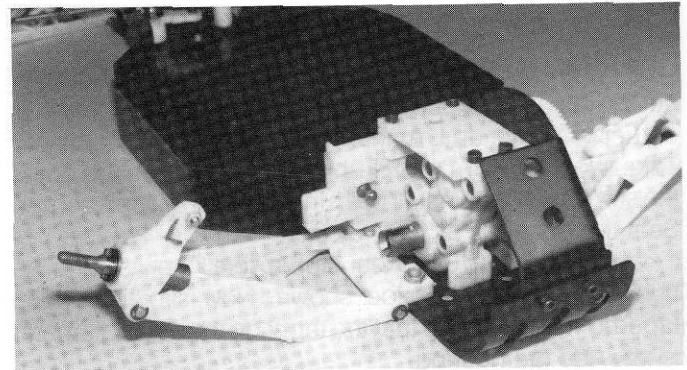

Fig. 97

□ **Figs. 98 & 99** From Bag 7-8, take the #6372 dogbone spring and install it inside the #6374 outer axle. Then align the slots and slip the #7361 dogbone in place. (Note: the technical term is 'rear half shaft', but 'dogbone' is more popular among racers.) Do the right hand side.

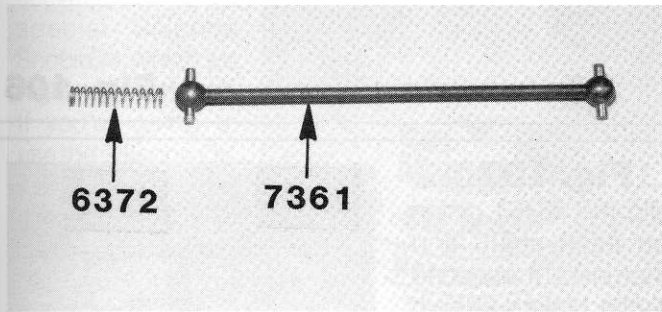

Fig. 98

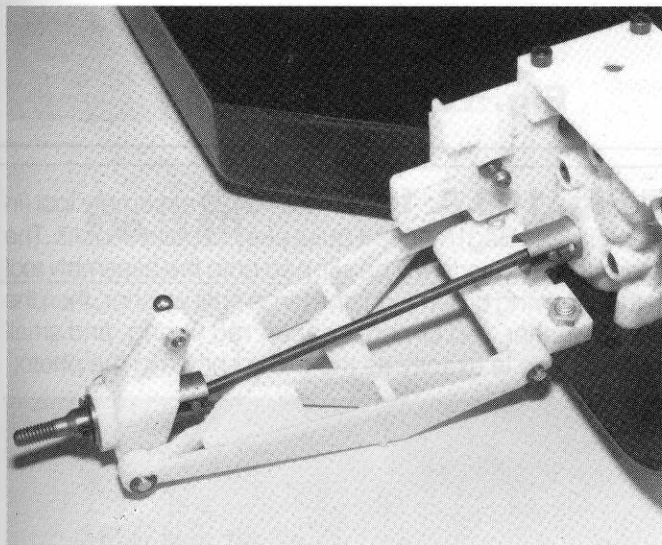

Fig. 99

□ **Fig. 100** Take two of the #7253 long turnbuckles, install and adjust the #6274 plastic ball cups to the dimensions shown. Note that on this strut one ball end faces forward and one faces to the rear.

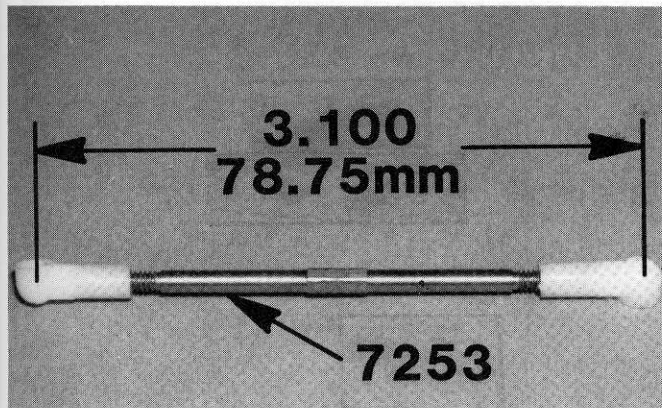

Fig. 100

□ **Fig. 101** Using a pliers, snap the ball ends in place, as shown. Do the right hand side.

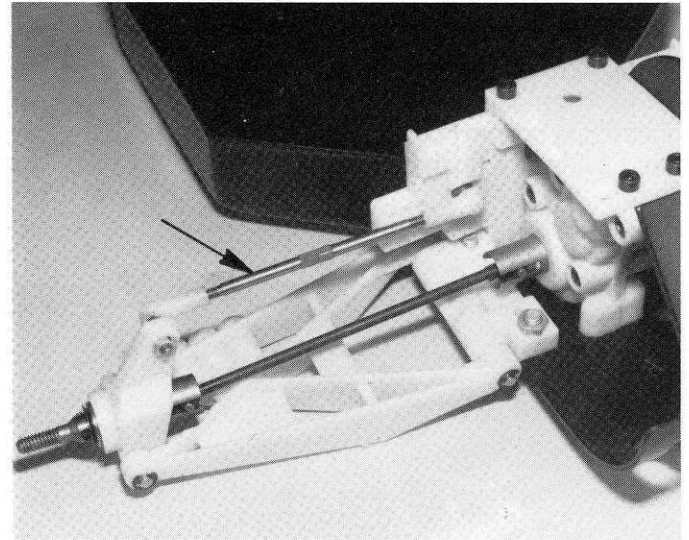

Fig. 101

□ **Fig. 102** From Bag 7-5 take out the two #7323 rear body mounts. Your body mounts will look just a little different than these. Mount the round part of the mount to the base with a 4/40 x 1/4" SHCS screw, as shown. Do both of them. Body clip holes should point to the left and right.

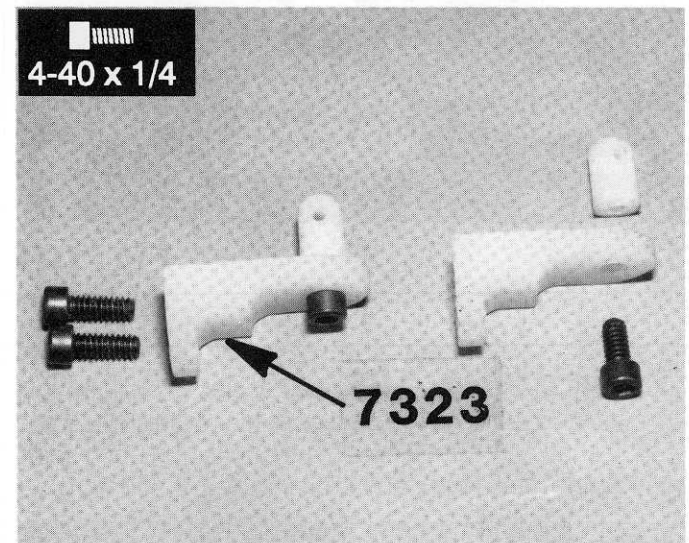

Fig. 102

□ **Fig. 103 & 104** Install the body mounts from Bag 7-5 to the #7353 rear shock strut from Bag 7-4 in the location shown, using the center of the three holes for the 4/40 x 5/16" SHCS mounting screw. Although the photo shows two mounting screws, your mounts only require one screw. The mount is held in alignment by a short knob that goes in the bottom hole. Now attach the shock strut to the rear bulkhead with the four 4/40 x 1/2" SHCS screws, as shown.

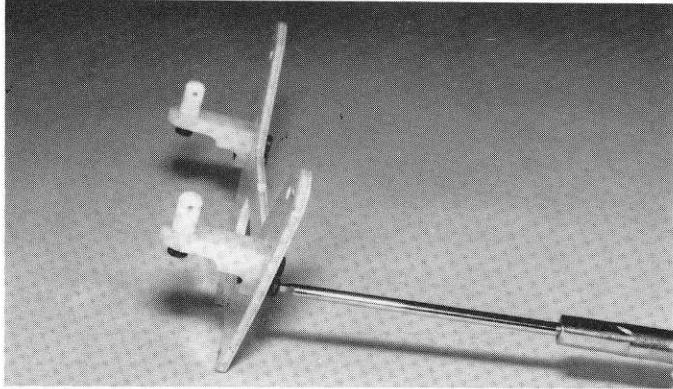

Fig. 103

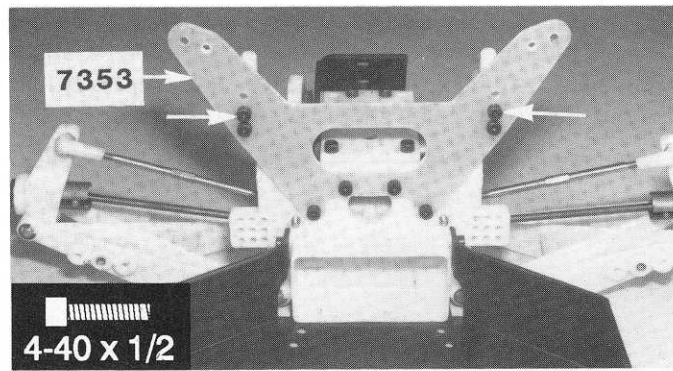

Fig. 104

□ **Fig. 105 & 106** It's easier to build all four shocks at the same time, so take all four of the #6459 and #6458 shafts and install one of the E-clips on each shaft, as shown. The shock parts are in Bags 7-9 and 7-10.

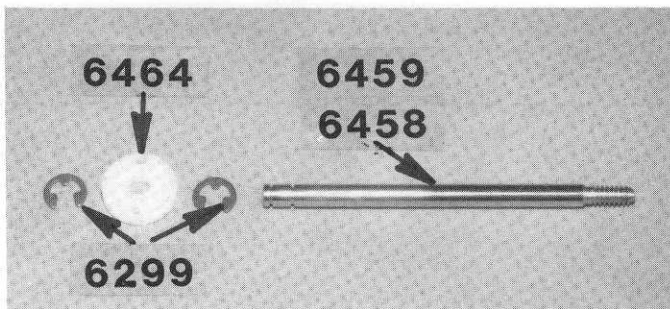

Fig. 105

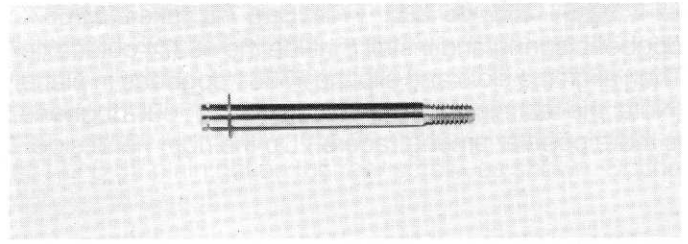

Fig. 106

□ **Fig. 107** Now slip the #6464 piston on each shaft, and then install the second E-clip. Make sure both E-clips are fully seated in the groove.

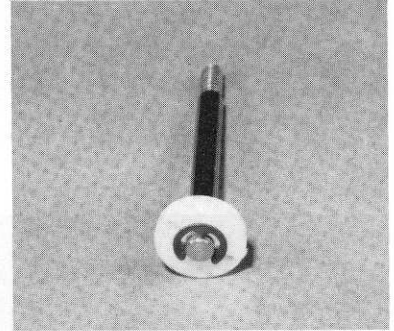

Fig. 107

□ **Fig. 108 & 109** The #6429 assembly tool (in master parts Bag) makes it quite easy to build shocks. The internal shock parts will be slipped onto the assembly tool in the following order. First, the large split washer, then the small washer, red O-ring, spacer, red O-ring, and small washer. This is exactly as the order shown in the photo.

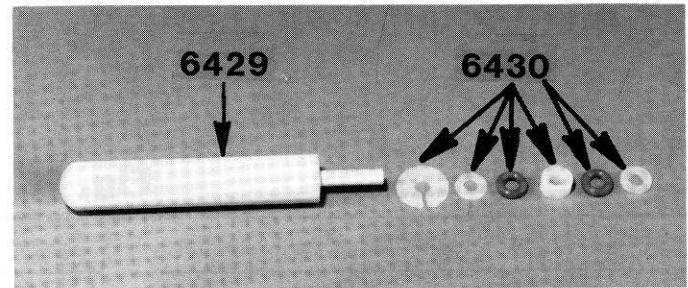

Fig. 108

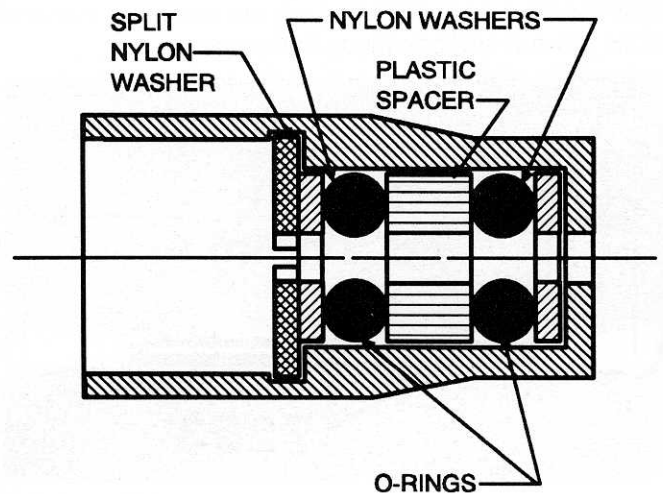

Fig. 109

❑ **Fig. 110**

Your kit comes with a very high-quality shock oil, but if you want the best, Associated also has a special Silicone Shock Oil, which we highly recommend. If you're going to use the Silicone Oil, then do not build the shocks with the kit oil, because the two oils will not mix. This oil is one of our Speed Secrets!



Fig. 110

❑ **Fig. 111** Apply a liberal amount of oil to the parts on the installation tool.

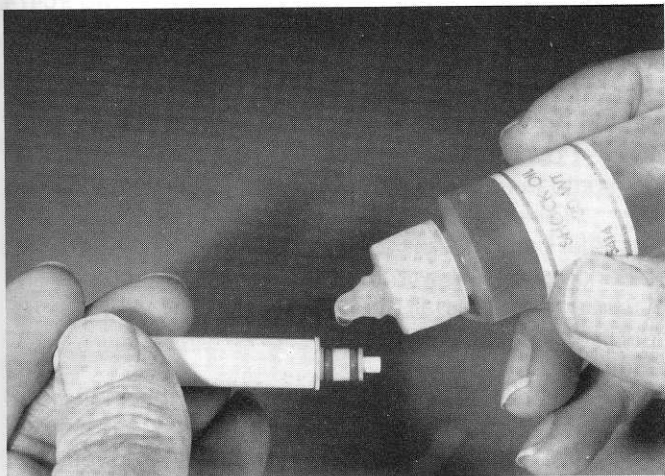

Fig. 111

❑ **Fig. 112** Put a few drops of oil into the #6436 front and #6435 rear shock bodies to make assembly easier also. We don't want to cut the red O-rings on assembly.

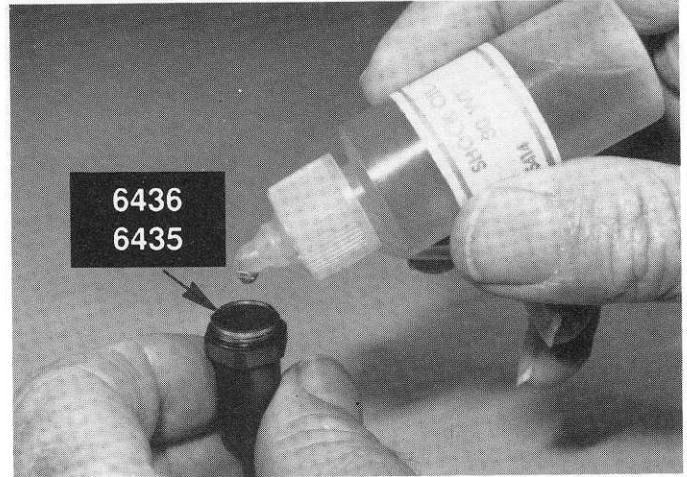

Fig. 112

❑ **Figs. 113, 114 & 115** Now take the shock body and the installation tool and push the parts slowly into the shock body all the way down until it bottoms out. Then give it a hard push to seat the split washer. You should be able to hear the washer snap into place. Pull the installation tool out. Look into the shock body to check the installation. **IMPORTANT!** The split ring should look like fig. 114. If it looks like fig. 115, then the washer is not seated in the lock groove and the shock will come apart. **MAKE SURE THE WASHER IS FULLY SEATED IN THE GROOVE.** (Note: To remove the parts, take the installation tool, insert it up through the bottom of the shock, and push the split washer out.)

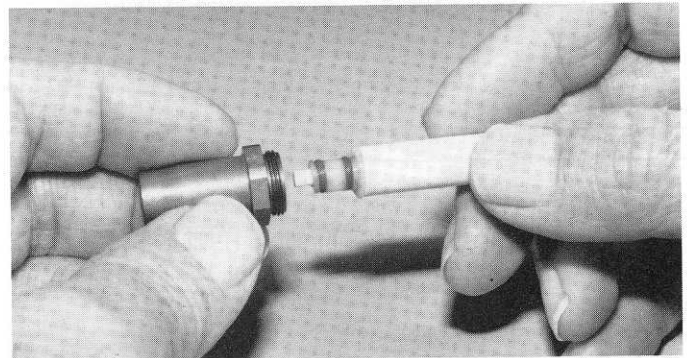

Fig. 113

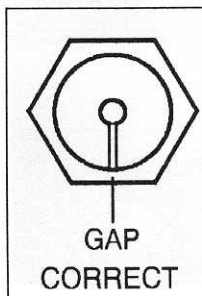

Fig. 114

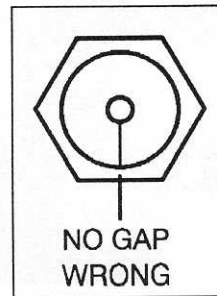

Fig. 115

- **Fig. 116** After the split washer is fully seated, place a liberal amount of oil on the short shock shaft and slowly push it into the shock, and pull it all the way to the bottom.

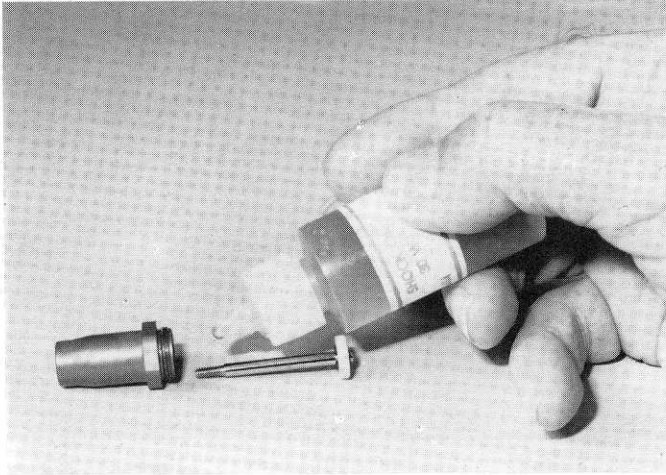

Fig. 116

- **Fig. 117** Slip the #6469 black O-ring over the threads and seat it against the pocket at the bottom of the threads.

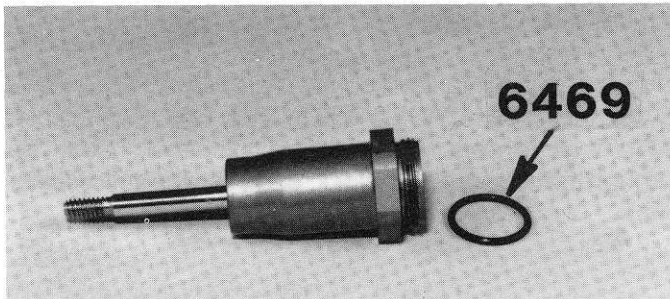

Fig. 117

- **Fig. 118** IMPORTANT: Thoroughly lubricate the threads in the cap BEFORE installing. IT MUST BE LUBRICATED FOR PROPER INSTALLATION. We'll install it in a minute.

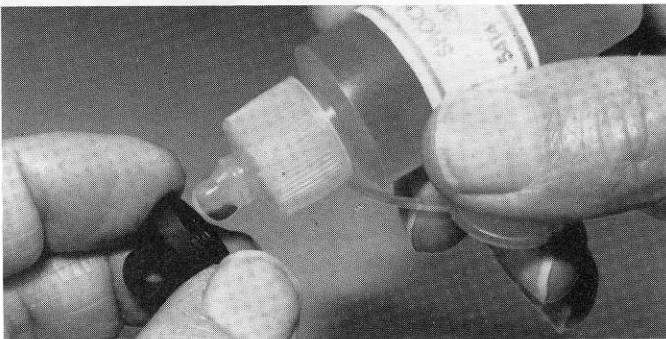

Fig. 118

- **Fig. 119** Fill the front shocks all the way to the top, but fill the rear shocks only to within 1/16" of the top.

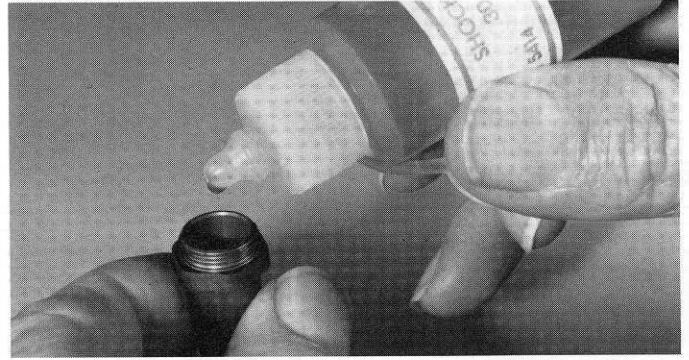

Fig. 119

- **Fig. 120** Push the shaft up so the piston is up to the top of the body, otherwise there will be too much internal pressure. VERY CAREFULLY screw the shock cap onto the body, making sure the cap goes on straight. BE CAREFUL not to crossthread the cap.

The cap needs to screw all the way down to the shock body. There should be no gap between the cap and bottom where the arrow is indicating. The O-ring will actually be doing the sealing so we must BE CAREFUL not to overtighten the cap and strip out the threads. As soon as the cap comes into contact with the body just turn it a VERY SMALL amount to seat it.

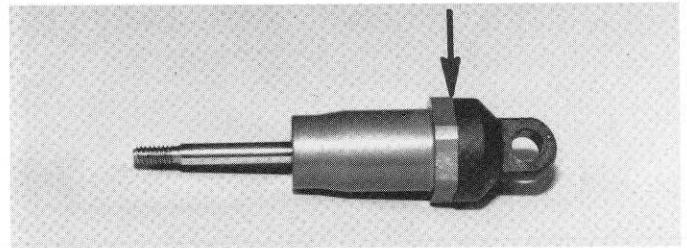

Fig. 120

- **Fig. 121** From Bag 7-11 install the two #6474 spring clamps on the rear shocks. The spring should go over the thin flange. Push the screw through the larger hole of the spring clamp and thread it into the smaller hole to tighten. Tighten the screws just enough to lock the collars. DO NOT overtighten. Take the long gold springs and slip them onto the shocks.

Take the #6471 plastic rod end and push it onto the metal ball. The easiest way to do it is to lay the metal ball end on a table with the flat end on the table. Set the plastic end on the ball and push it in place with your 1/4" nutdriver. Or you can use a pliers to squeeze the parts together.

Then thread the plastic ball end on the shaft. You'll have to keep the shaft from rotating with a needle-nose pliers. Grab the shaft close to the threads so that you don't scratch the part that rides in the "O" rings. With your spring on the shock, snap in the plastic split spring collar.

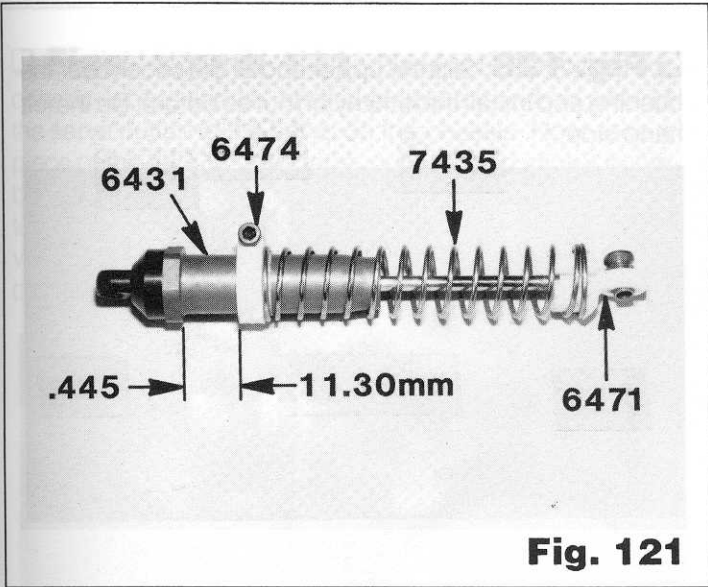

Fig. 121

□ **Fig. 122** On the front shocks, install the spring collars, as shown. Use the short gold springs.

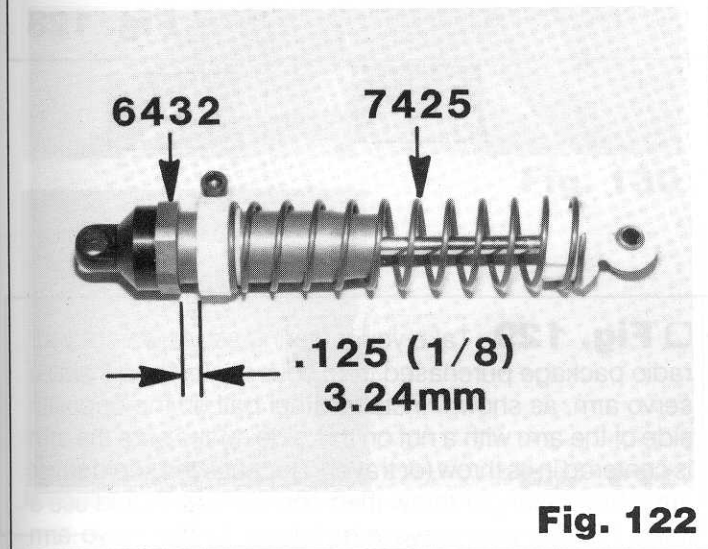

Fig. 122

□ **Figs. 123 & 124** From Bag 7-1 take one of the long #7420 4/40 x 5/8" Special SHCS screws that has threads on the end only. Slip the shaft end of the right hand front shock into the slot of the front A-arm, as shown. make sure the flat flange of the steel ball is towards the rear. Install the screw in the direction the arrow shows. Do the left hand side.

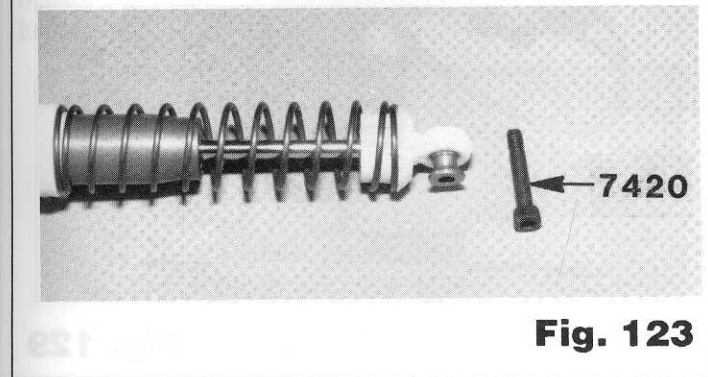

Fig. 123

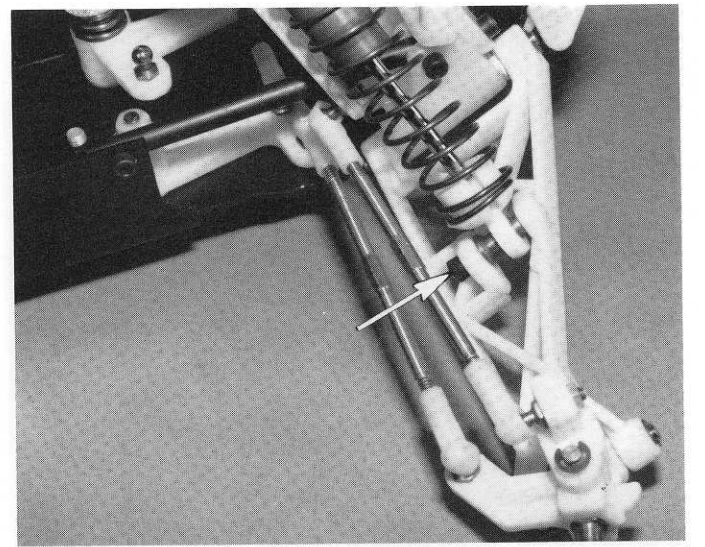

Fig. 124

□ **Figs. 125 & 126** From Bag 7-9, add a washer to each 4-40 x 3/4" shock mount screws and tighten with nuts as shown, with threads toward the front. Slip one of the #6473 plastic shock bushings on each of the four upper shock mounting screws, as shown, so that the thick flange part is towards the rear, as shown. Slip the upper shock cap onto the bushing, and screw on the #6295 4/40 plastic nut. Just screw the nut on till it touches the bushing, then stop, otherwise you'll compress the bushing and bind the movement of the shock. Do the left hand side.

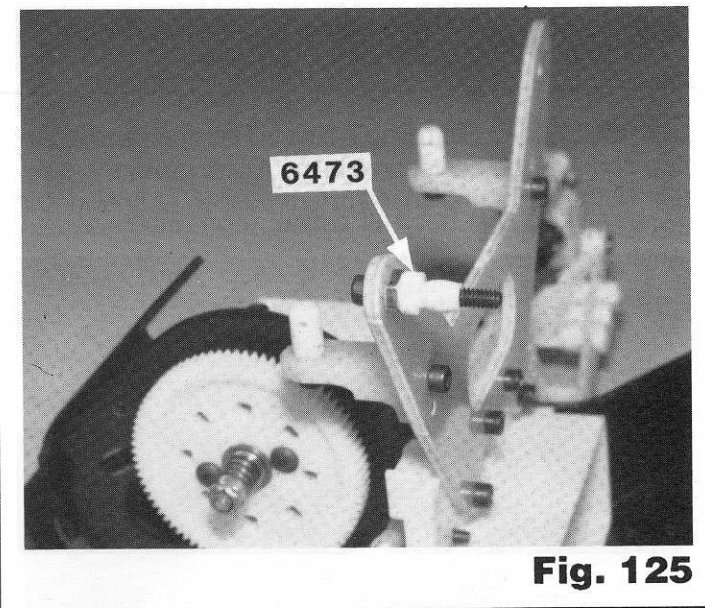

Fig. 125

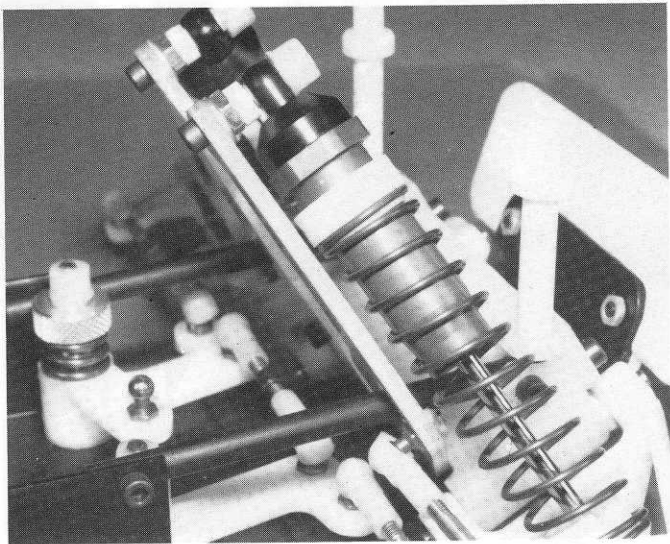

Fig. 126

□ **Fig. 127** From Bag 7-9 install the shaft end of the rear shock in the center hole in the A-arm using a 4/40 x 3/4" SHCS screw and an aluminum washer, as shown. Do the left hand side.

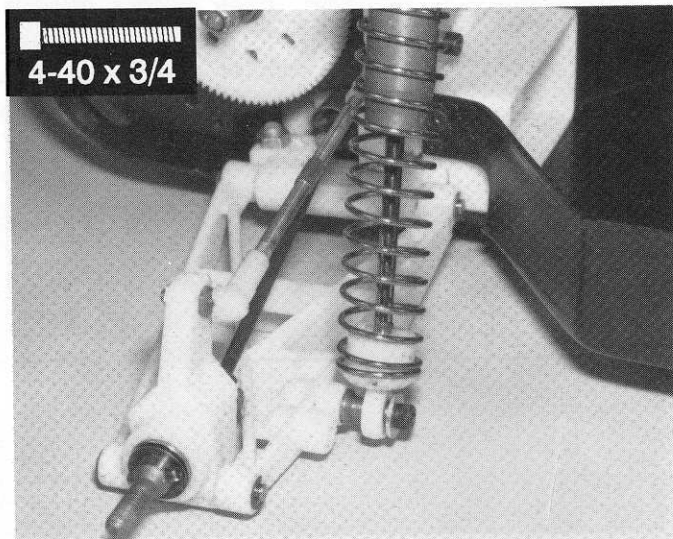

Fig. 127

□ **Fig. 128** Slip the upper end of the shock over the bushing and install the 4/40 nylon nut as before. Do the left hand side.

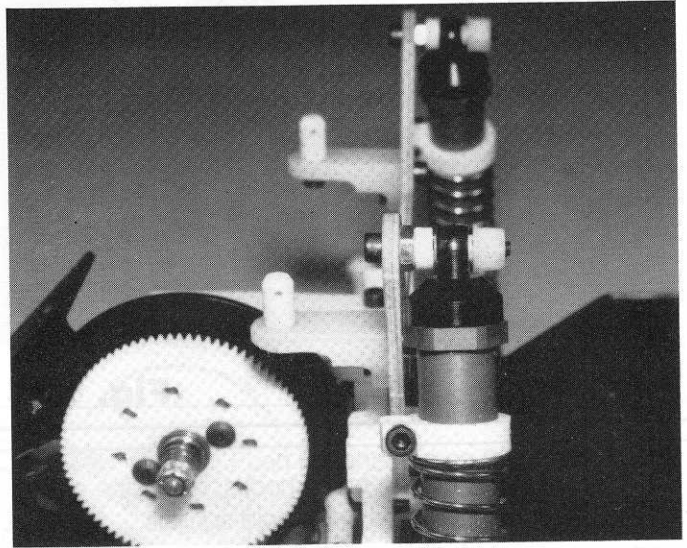

Fig. 128

□ **Fig. 129** Take your steering servo (part of your radio package purchased from your dealer) and install a servo arm, as shown. Install a steel ball on the opposite side of the arm with a nut on this side. Make sure the arm is centered in its throw (or travel). Because the servo saver arms have a longer throw than normal, you should use a lower hole in your servo arm (closer to the servo arm screw.)

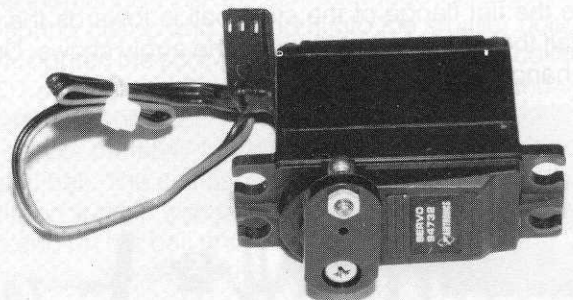

Fig. 129

□ **Figs. 130 & 131** Place your servo on your chassis, where shown, and take a pencil and go around the servo outlining the servo on the chassis. Now, take a piece of the #4326 servo tape, cut it off and stick it to the bottom of the servo. This stuff is very sticky, so be careful to position it right the first time. Peel off the backing. Now, very carefully position the servo directly above your pencil outline and press the servo against the chassis very firmly.

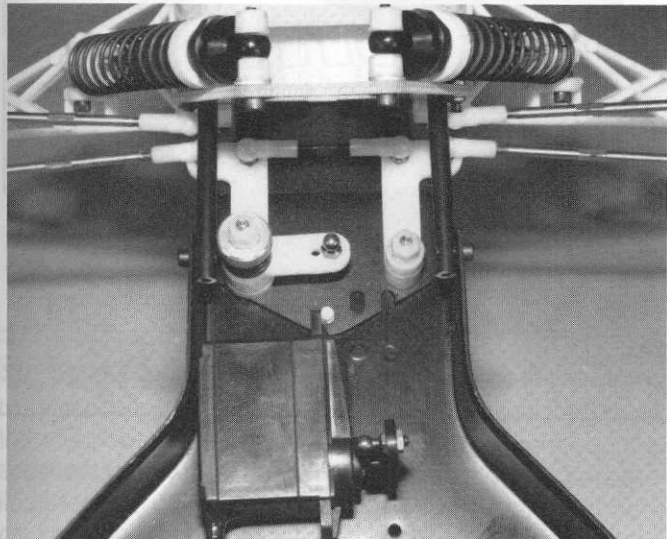
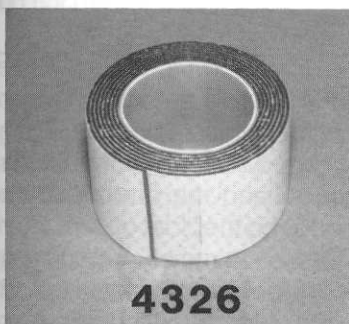

Fig. 130



4326

Fig. 131

□ **Figs. 132 & 133** Position the arm on the servo straight up. Center the servo saver left to right. Now measure the distance between the center of the ball on the servo arm and the center of the ball on the servo saver and make the #7552 final turnbuckle to that length. Snap on the turnbuckle.

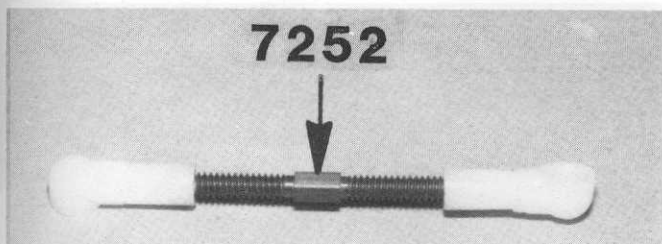

Fig. 132

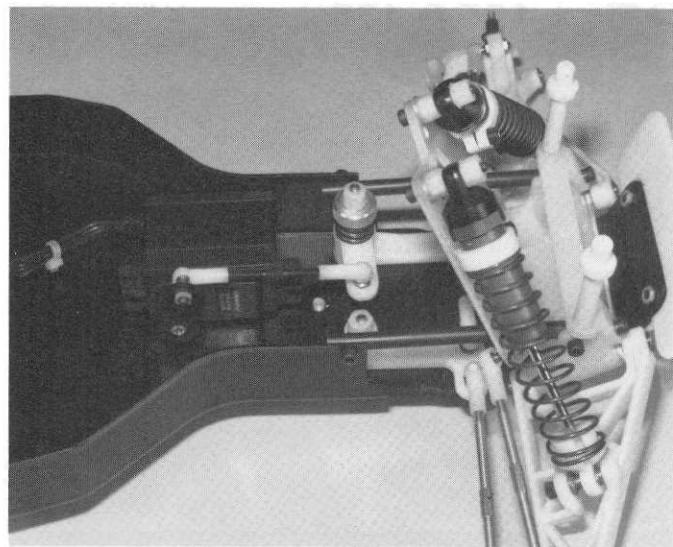

Fig. 133

□ **Fig. 134** Install the #6338 antenna mount on the chassis, where shown, with a flat head 4/40 x 1/2" screw.

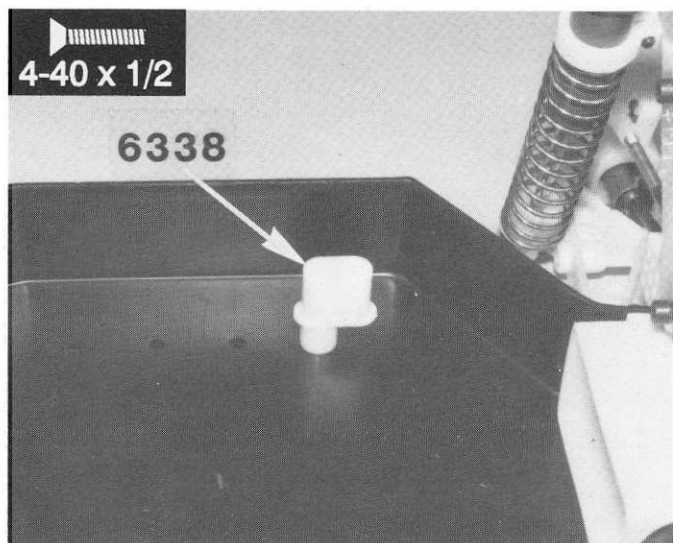

Fig. 134

□ **Figs. 135 & 136** From Bag 7-7 take one of the #6334 battery cup out and screw the two 4/40 x 1/2" SHCS screws in, as shown. One screw will have a very small hole in the head. The screws DO NOT go all the way down. There must be enough room between the screw head and battery cup for the #6335 battery strap to mount and swing freely.

Install the strap by placing the end of the strap marked "B" over the screw head that has no hole. Slide the strap over into the groove and then slip the "A" end over the screw head with the hole in it. Slip the #6332 body clip into the hole.

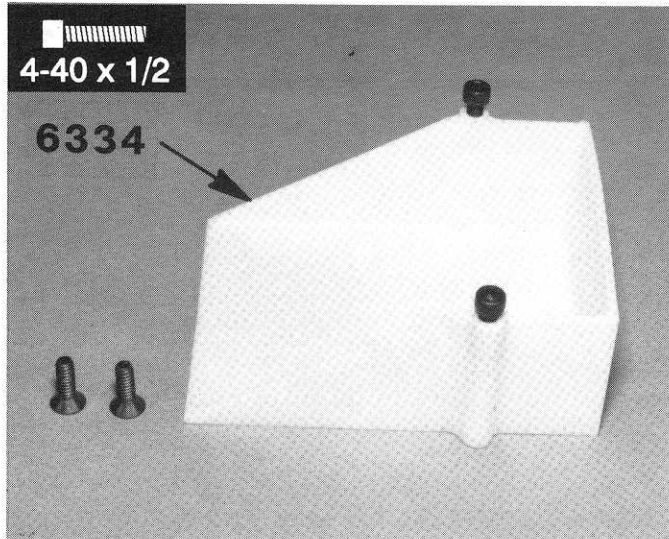

Fig. 135

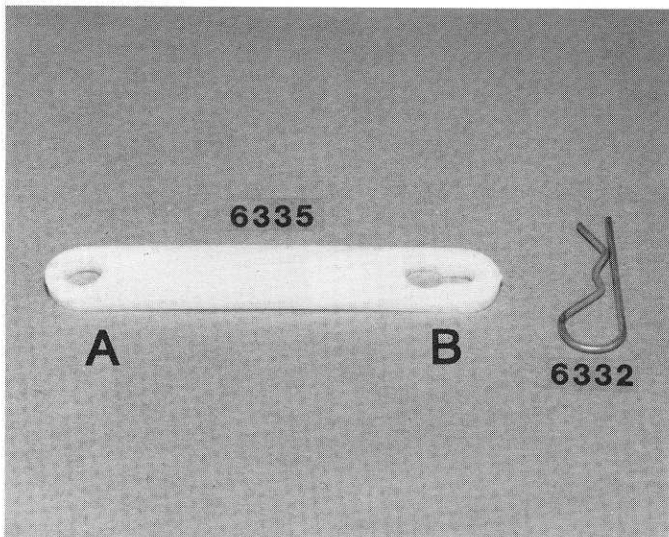

Fig. 136

□ **Fig. 137** Install the battery cup in the chassis with two flat head 4/40 x 1/2" screws where shown.

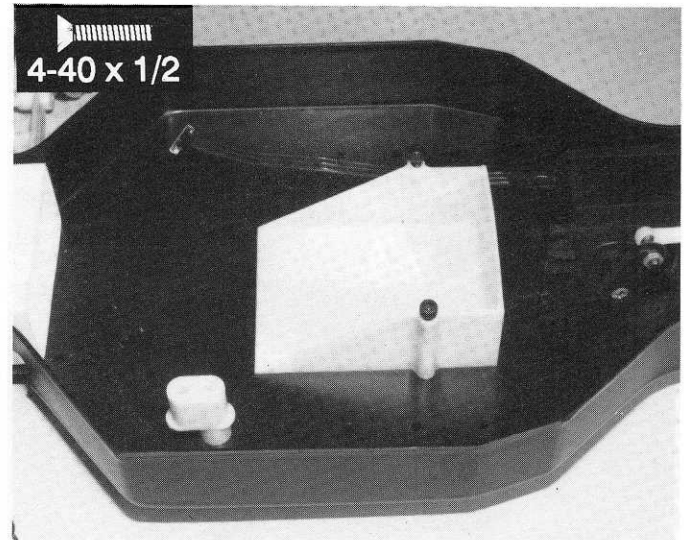

Fig. 137

□ **Figs. 138 & 139** Time to put the horsepower in the car. This kit does not come with a motor. We highly recommend REEDY motors. You will have to pick up the motor, motor mounting screws, and the correct pinion from your local dealer. You will need to solder on the motor lead wires and filter capacitors to the motor according to the instructions included with the motor and/or speed control. Make sure that you are using ROSIN core solder to make your electrical connections. Your dealer should be able to recommend the correct pinion for the motor you decide to run. We no longer can recommend a pinion gear because of the wide range of pinion sizes used, even on stock motors, due to some of the improved performance in motors. As a starting point, the end of the pinion should be even with the end of the motor shaft.

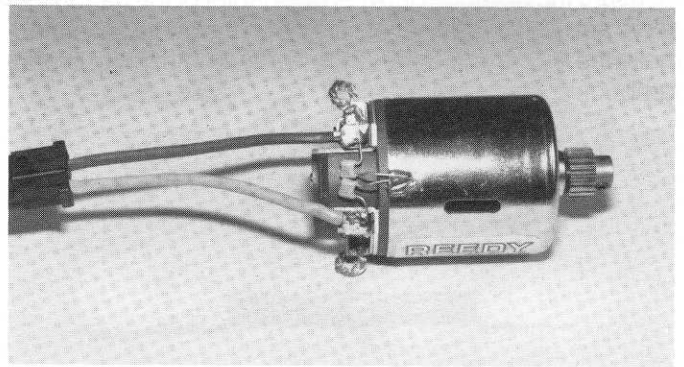

Fig. 138

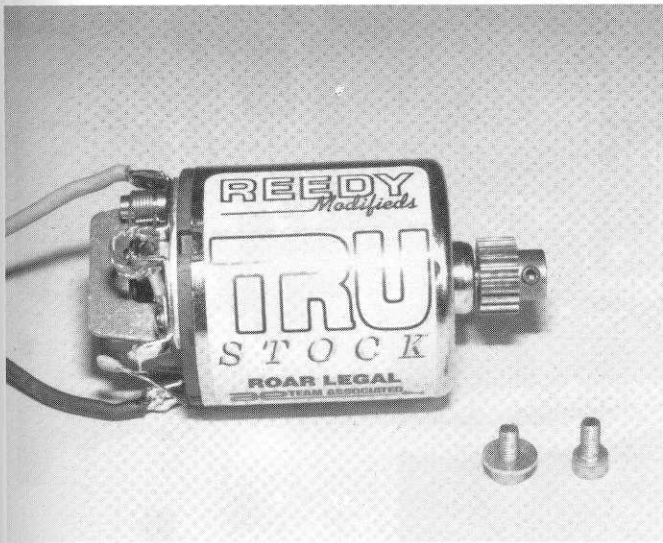

Fig. 139

□ **Figs. 140 & 141** Slip the motor in the motor mount and start the bottom screw in first. Do not tighten all the way down yet. On the top screw, put a washer on the screw and screw it in, but not tight. **NOTE:** Most motors are imported and use 3mm mounted screws, which are different from the rest of the fasteners in the kit. Make sure you do not mix them up.

Now we'll set the gear mesh. By moving the upper screw forward or back, we'll be moving the motor closer to or away from the plastic spur gear. What we want to do is get the metal pinion gear as close to the plastic spur gear as we can without binding up the gears. The easy way to check this is to put your finger on the plastic gear and see if you can rock it in the teeth of the metal gear. The two gears should be as close as possible, while still being able to very slightly rock the plastic gear. When you have this correct spacing, tighten down on the two motor screws and re-check the gear spacing. An incorrect gear mesh can result in a huge power loss, so do it correctly.

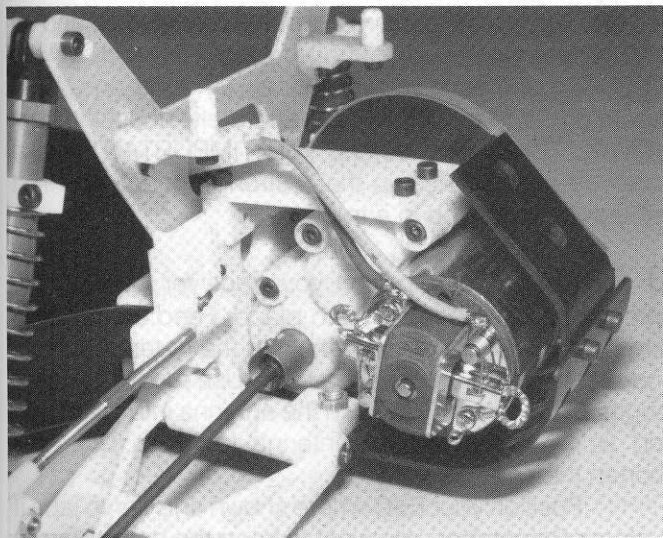

Fig. 140

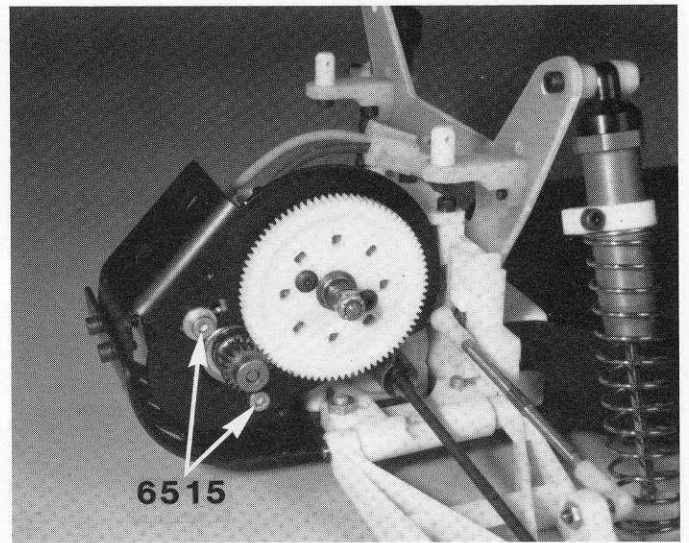

Fig. 141

□ **Figs. 142 & 143** Trim around the outside of the #6608 dust cover, cut out the center button hole and install with two 4-40 x 1/4" SHCS and washers. **CAUTION:** to remove the motor, you must first remove the dust cover. You will then have four screws out that look the same. But if you mix up the dust cover screws with the motor screws, you will strip out the threads. Keep the motor screws with the motor, and the dust cover screws with the dust cover. Also, **DO NOT** try to use aluminum screws to attach the dust cover, because the screws will break off when mounting the dust cover.

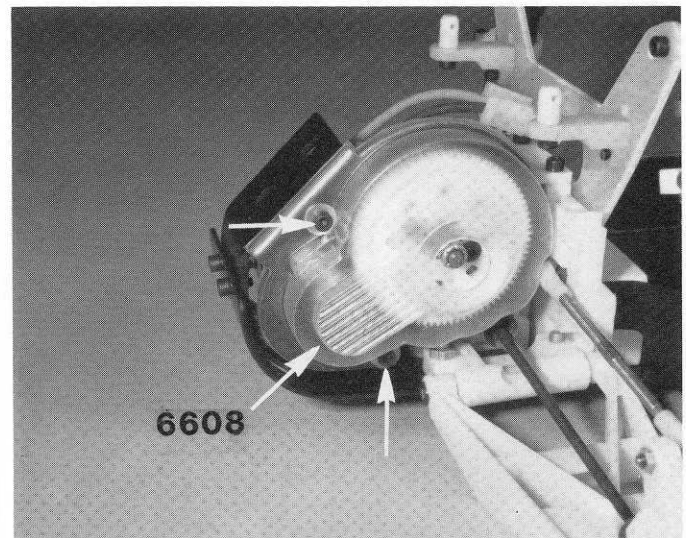

Fig. 142

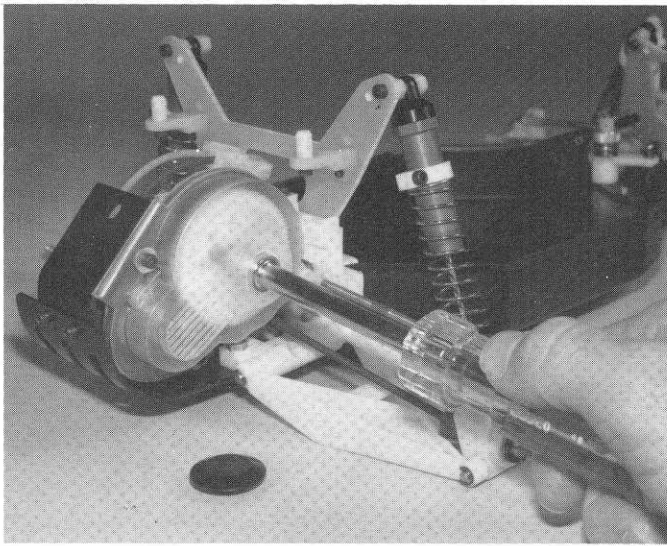

Fig. 143

Figs. 143 & 144 You will be able to make clutch adjustments easily by removing only the button. On slippery tracks, slip the clutch a little more. On high traction tracks, tighten it up a little more. You can adjust the clutch to your driving style. Make sure you always reinstall the button.

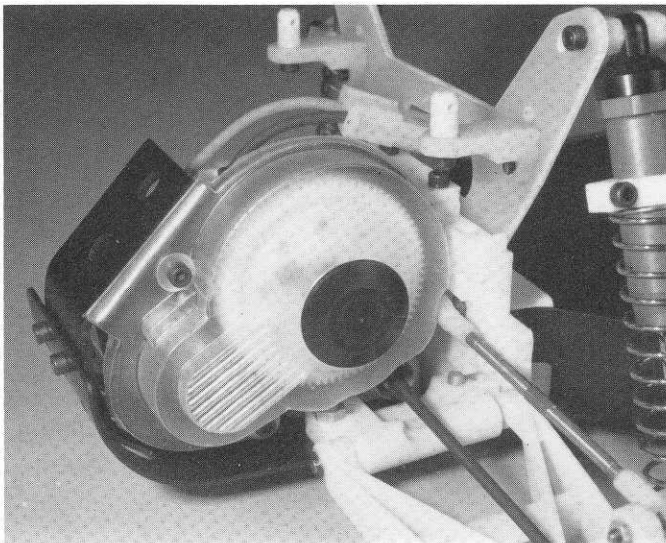

Fig. 144

RADIO INSTALLATION

Choose a good radio! FUTABA and AIRTRONICS are the most popular, but there's also some other good ones available. If you're going to race in competition, get the best radio you can afford.

Some radio systems come with one servo and an ESC (Electronic Speed Control). If your system comes with an ESC, make sure you've chosen a good one. Most racers prefer to buy their ESC separately, choosing from NOVAK, TEKIN, and others. **VERY IMPORTANT:** make sure you choose a servo that's strong enough and fast enough to do the job in a truck.

Fig. 145 Position your receiver close to the antenna and servo tape it into place. Feed the antenna wire up through the antenna hole in the antenna mount, and then through the antenna tube. Use the full antenna length. Do not shorten it. Push the antenna into the mount and tie wrap the excess antenna together. **DO NOT** shorten the antenna wire.

Position your ESC where shown and servo tape it in place. Remember, you want to keep the power (large) wires on your ESC as short as possible.

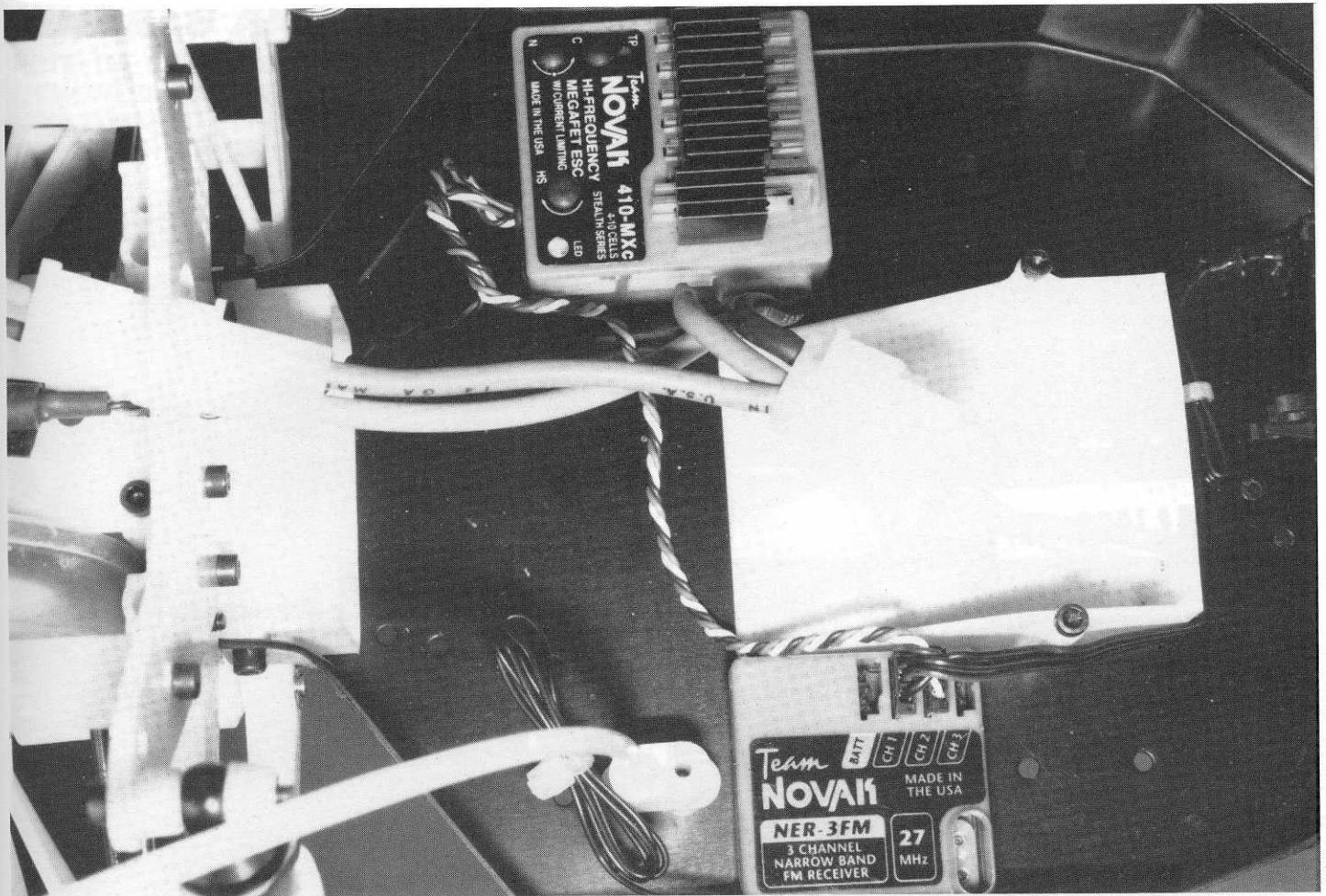

Fig. 145

□ **Fig. 146** The arrow shows a popular place to mount your ESC ON/OFF switch. It's easy to reach with the body on.

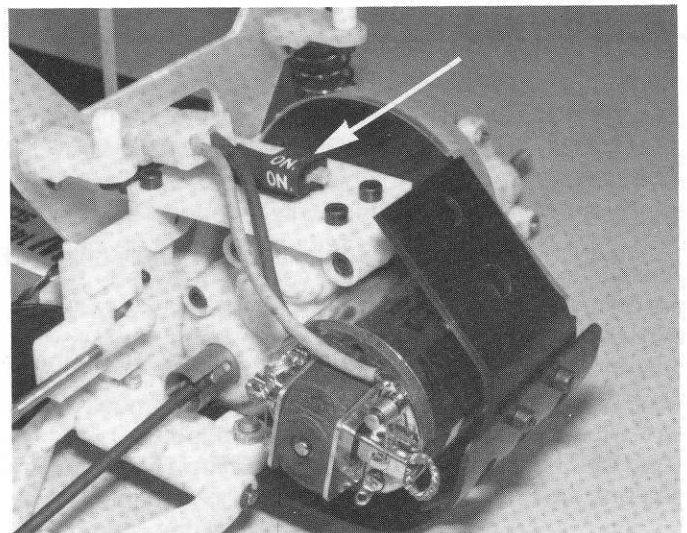

Fig. 146

Fig. 147 Your completed radio installation should look like this.

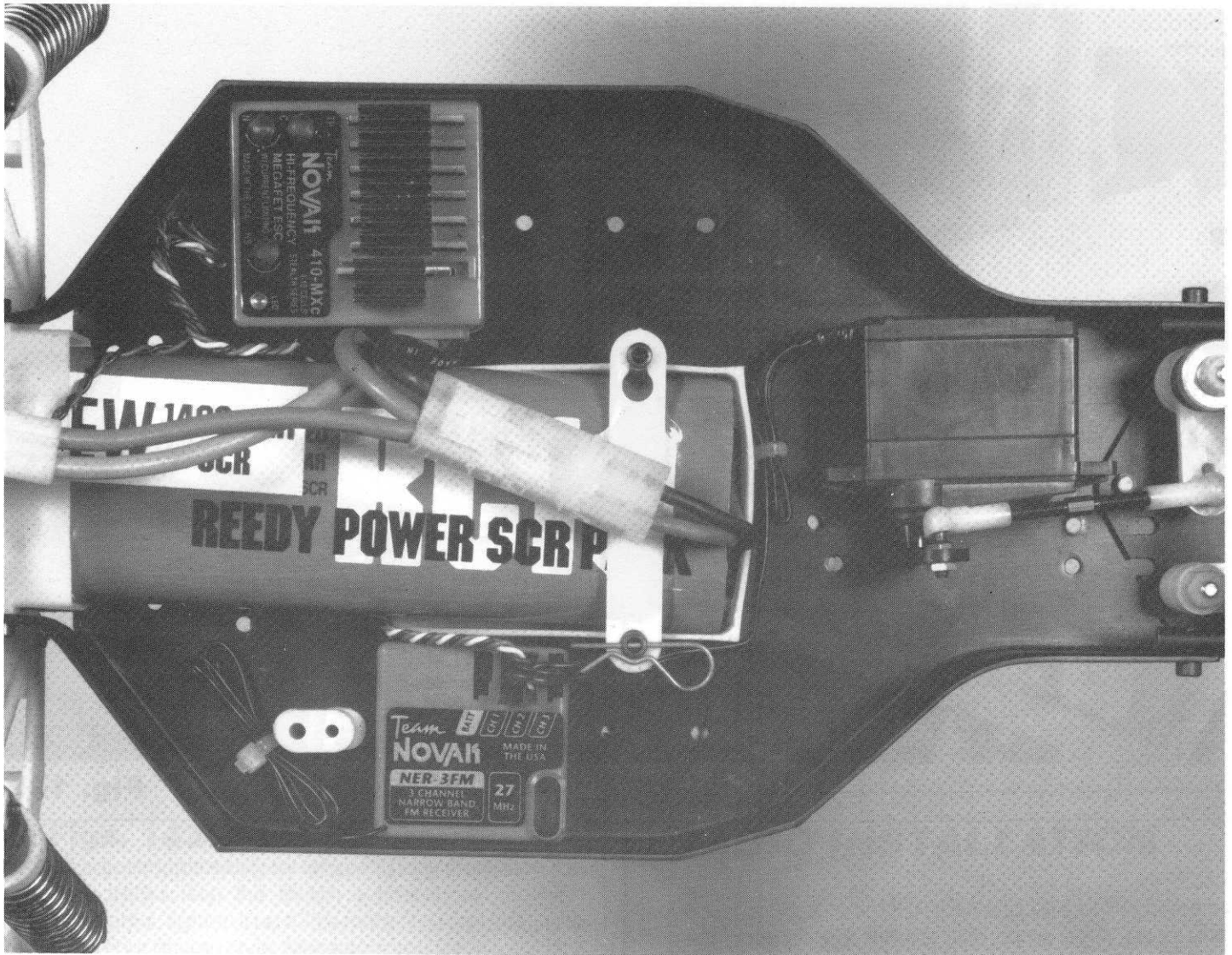

Fig. 147

- INSTALL THE RADIO PER THE RADIO MANUFACTURER'S INSTRUCTIONS.
- INSTALL THE ESC (Electronic Speed Control) PER THE ESC MANUFACTURER'S INSTRUCTIONS.
- INSTALL THE MOTOR PER THE MOTOR MANUFACTURER'S INSTRUCTIONS.
- CHARGE AND INSTALL THE BATTERIES PER THE BATTERY CHARGER MANUFACTURER'S INSTRUCTIONS.

WHEELS AND TIRES

NOTE: THE TIRES IN YOUR KIT MAY LOOK DIFFERENT FROM THE TIRES IN THE PHOTOS. WE PUT IN THE BEST TIRES FOR MOST CONDITIONS, REPLACING THEM AS TIRE DESIGN ADVANCES.

Figs. 148 & 149 Take the #7820 rear tire and insert the #7800 sleeve into the tire. Do both tires.

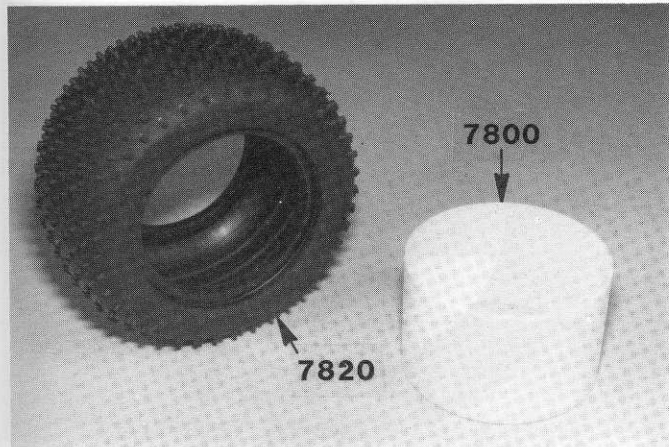

Fig. 148

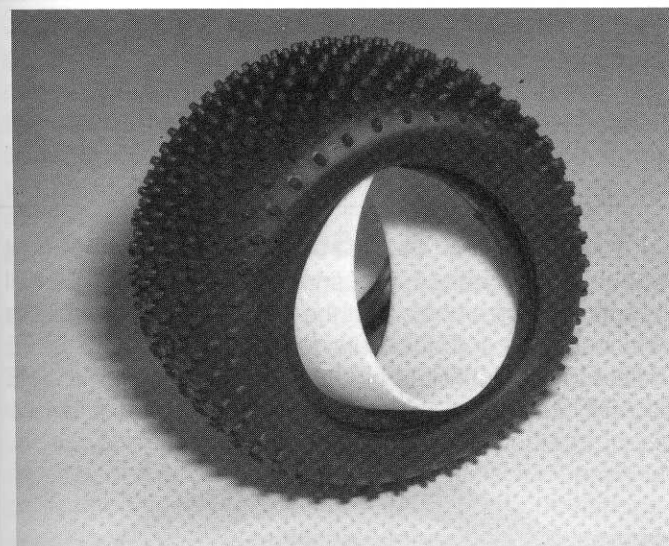

Fig. 149

Figs. 150 & 151 Make sure the sleeves are centered in the tires. The inside half of the wheel has the big hole in the center. The inside halves of the front and rear wheels are exactly the same.

Take one of the inside wheel halves with the big hole in it and one of the outside halves with the very smallest hole in it. Push the inside wheel half into the tire, seating the tire evenly. Push the outside wheel half into the tire, making sure to keep the screw holes lined up. Also, make sure the tire is seated evenly. Install the four longest 4/40 x 5/8" screws. Do not overtighten. Do the other rear wheel and tire.

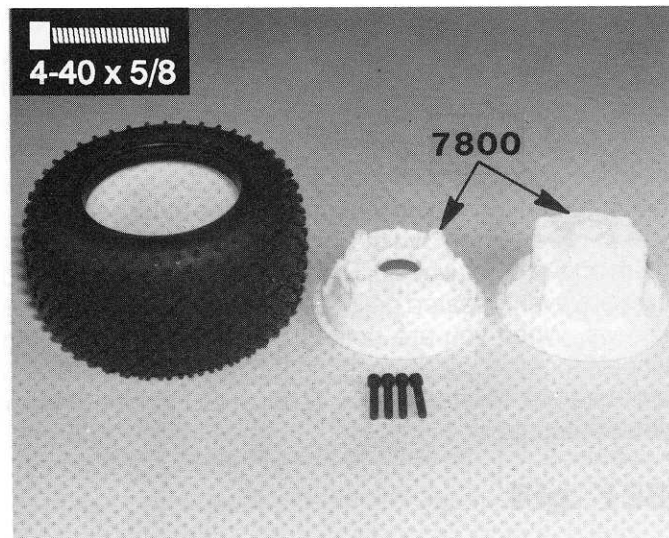

Fig. 150

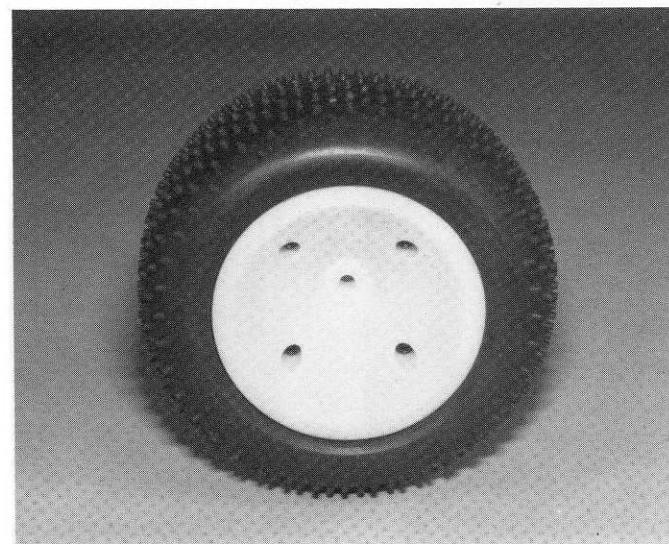

Fig. 151

Figs. 152 & 153 When we designed the RC10T truck, we looked at the ROAR rules and there was no minimum dimension listed for the front wheels and tires. Because what we were designing was similar to Stadium Trucks, we wondered why nobody was using narrow front tires, as on Stadium Trucks.

So, we made some narrow and wide front wheels and tires and did some testing. We ended up running the narrow front wheels and tires at the FLORIDA WINTER CHAMPIONSHIPS and finished 1st and 2nd. Everyone that's seen the truck wanted the narrow wheels and tires.

But, because there might be some tracks that require wide front wheels and tires, we've included parts to make narrow or wide ones. Try them both out and see which ones you like.

Put the appropriate rings in all four front tires. Next we will install the shallow outer wheel halves in the narrow front tires and the deep outer wheel halves in the wide front tires. Now you will need to decide which of the front tires you intend to run. You will then take the one set of inner front wheel halves and mount them to the tires that you have chosen. When you decide to run the other set of tires, you will need to remove the inner wheel halves and install them on the other wheels. Make sure that the wheels and tires are evenly seated before you tighten down the wheel screws. When you are bolting the wide front tires and wheels together please use the longer 4/40 x 5/8" SHCS and use the shorter 4-40 X 7/16" SHSC for the narrow wheels and tires.

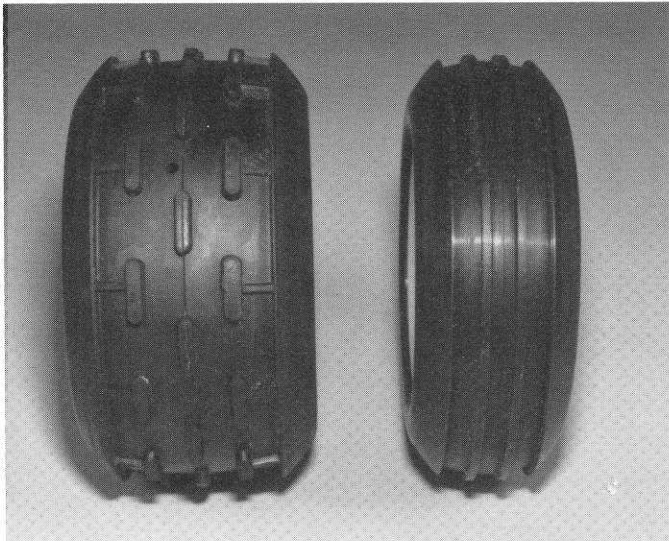

Fig. 152

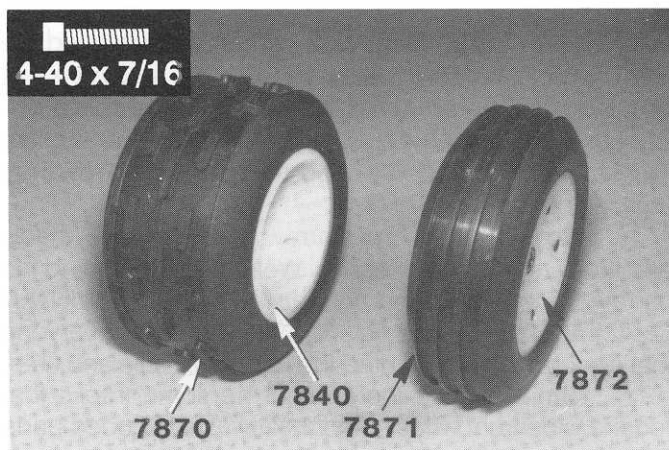

Fig. 153

Fig. 154 Install the rear wheel on the rear axle. You'll probably have to turn the wheel until you seat the groove in the back of the wheel over the split pin in the rear axle. When the wheel is correctly seated, install and tighten the 8/32" axle lock nut. Do both sides.

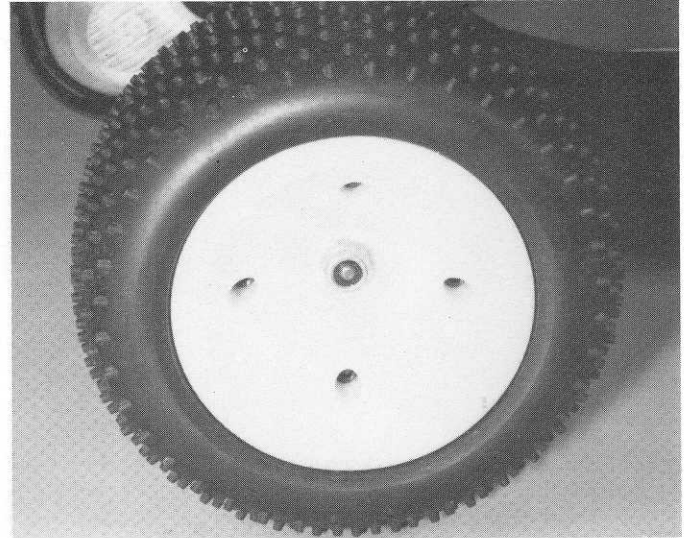

Fig. 154

Figs. 155 & 156 Pick out the pair of front wheels you're going to run, and install the four #6906 ball bearings in the wheels. Put the wheels on the front axles and install the 4-40 locknuts. **IMPORTANT: MAKE SURE THE LOCKNUTS AREN'T TOO TIGHT AND BINDING THE BEARINGS.**

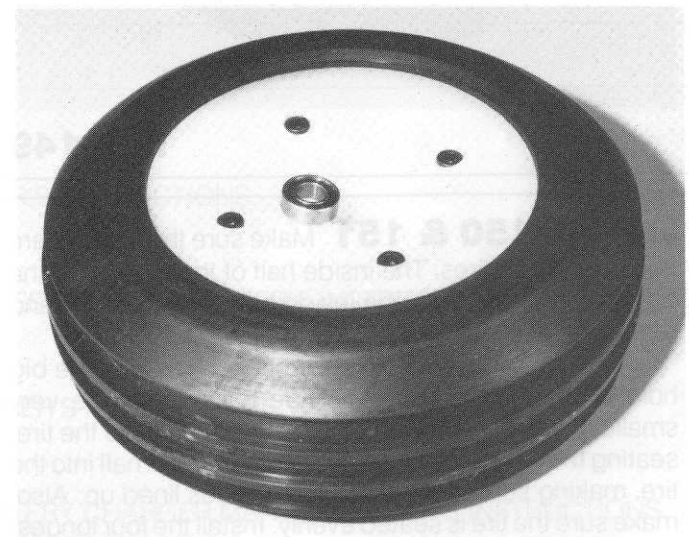

Fig. 155

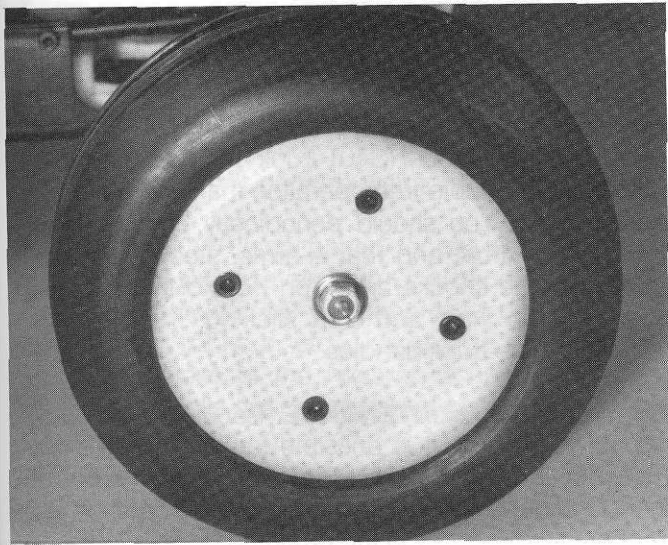

Fig. 156

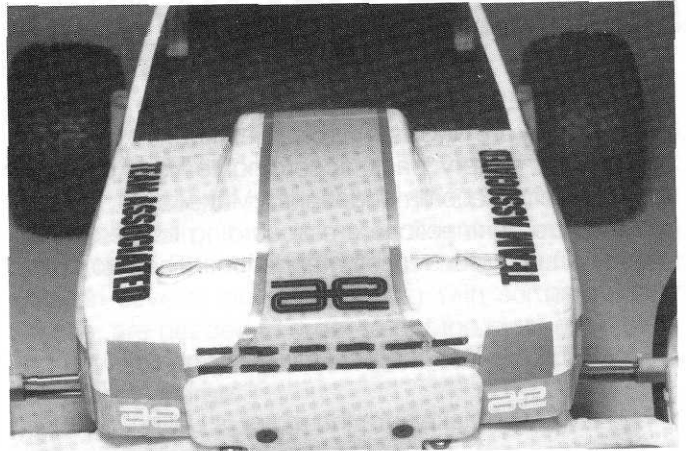

Fig. 158

Figs. 157 & 158 The body can be painted before you mount it, however, it might be easier for you to mount it while it's clear because it will be easier to locate the holes for the body mounts. Fig. 159 shows the trim lines for the body. Trim a little of the body and slip it on. Keep trimming a little at a time until it clears. Cut out the body mount holes. When you've got the body fitted, it's time to paint the body.

The body is painted on the inside. There are two different ways to paint the body, by either brushing it on or spraying it on. The body is made of lexan polycarbonate. In hobby shops, you can find special Lexan or polycarbonate paints made for these type bodies to brush on. Do not use any other type brush-on paints. If you want to spray it on, one of the best type of spray paints for Lexan or polycarbonate is Pactra, available in most hobby shops.

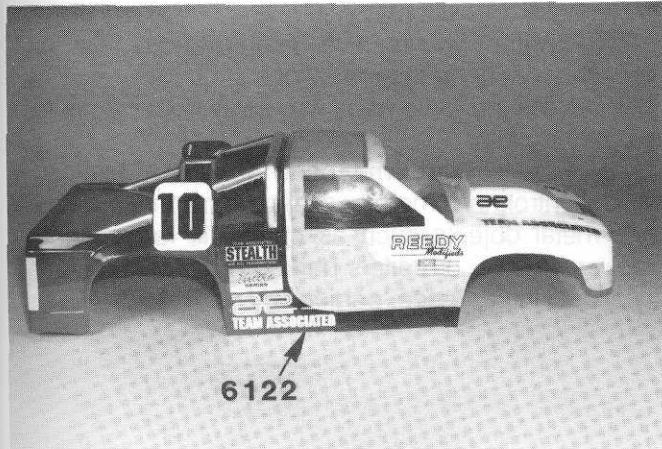

Fig. 157

Fig. 159 Apply decals to the body the way you want.

There are four large nylon washers that will fit over the top of the front and rear body posts. Use these to give the body more support. Mount the body and insert the four body clips.

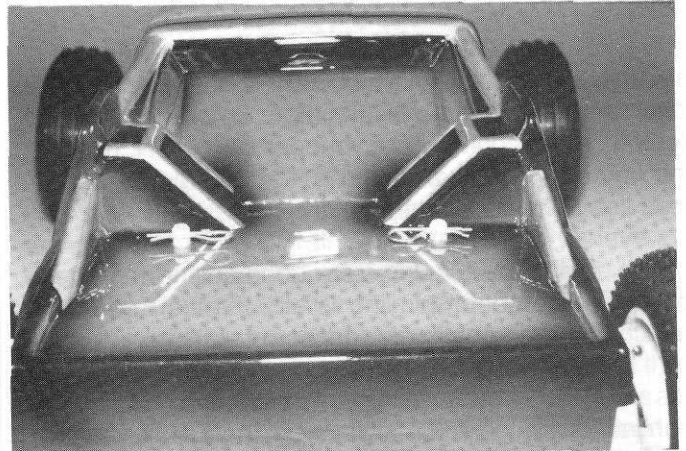

Fig. 159

Now pat yourself on the back. YOU DID FANTASTIC!
© 1991 ASSOCIATED ELECTRICS, INC.

FINAL ADJUSTMENTS

BATTERY CHARGING. Charge your transmitter batteries if they are Ni-Cds. This charge will take overnight. Charge your battery pack according to your charger manufacturer's recommendations. Make sure all the speed control connections are according to the speed control manufacturer's recommendations. Then go on to the following:

STEP 1—Turn the transmitter switch ON.

STEP 2—Make sure the motor is UNPLUGGED.

STEP 3—Plug in your car batteries.

STEP 4—Turn the car switch ON.

STEP 5—Turn the steering wheel to the right. See if the wheels turn to the right. If they turn to the left, you have a steering servo reversing switch in the transmitter that should be switched to the opposite position. Read your radio manual for more details.

STEP 6—When your wheels turn in the correct position, take your hands off the steering wheel. Is the servo arm on the steering servo centered? Refer to Fig. 129. If it's not centered, you'll have to remove the servo arm screw and center the arm.

STEP 7—Are your wheels now pointed straight forward? If not, refer to Fig. 133 and adjust the turnbuckle to correctly loosen the two linkage set collars, center the wheels, then re-tighten the collars.

STEP 8—Leave the transmitter switch ON. Turn the car switch OFF. Plug your motor into the speed control.

STEP 9— A word of caution here. You'll want to have the car sitting up on a block so the rear wheels cannot touch anything before you turn the car switch back on to set the speed control. Turn your car switch ON. Now set the speed control according to the speed control manufacturer's recommendations.

STEP 10—When you're done setting the speed control (and probably playing with the throttle) turn the car switch OFF.

STEP 11—Turn the transmitter switch OFF. The transmitter switch must always be the **FIRST SWITCH TURNED ON** and **THE LAST SWITCH TURNED OFF**.

YOUR TRUCK IS NOW READY TO RUN!

RC10T TRUCK MAINTENANCE

You'll find your RC10T truck will give you many more hours of trouble-free operation than any other car available now. You should periodically check all the moving parts: front and rear A-arms, steering blocks, steering linkage, shocks, and so on. If any of these should get any dirt in them and start sticking, it will greatly impede how the truck handles.

MOTOR MAINTENANCE. Because we're running out in the dirt, it is possible for dirt to make the brushes stick. So, if you're having motor problems, one of the first things to check is to make sure the brushes are still able to move freely in the brush holders.

If you've run enough to wear them out, Associated has replacement brushes available. A helpful product which will give you a little more power and make the brushes and commutator last much longer is Associated's Reedy-in-a-Can Power Spray #750. Simply spray a short burst of this on the brushes and commutator every time before you run and it will clean and lubricate the brushes and commutator. For those of you who want more power, Reedy Modified motors are available from Associated. Reedy Modified's #550 for stock racing and #502 for modified are good starting choices.

RADIO MAINTENANCE. A radio problem is not always caused by the radio. Often it is the result of a combination of factors which can include motor noise, poor electrical connections or layout, reversed or defective crystals, weak transmitter battery, and so on. If your radio problems persist, one or all of the following tips may help:

Make sure your motor noise capacitors are properly installed.

Make sure the brushes are free in their brush holders and are not arcing.

Try a different frequency.

Try a different motor.

Lengthen your receiver antenna and/or raise the antenna mount up to the rear shock strut.

Dress the radio wires well away from the power leads of the motor.

Note also that 75 mhz band radios and Electronic Speed Controls are more susceptible to interference. Large metal objects such as chain-link fences, light poles, cars, vans, or trailers parked near the track can cause local interference, particularly on 75 mhz.

CHARGING BATTERIES

It is important to understand the characteristics of the battery pack in your truck because how you use it will greatly affect both its performance and its life. With proper care your pack will perform well for many hundreds of cycles.

The ROAR legal battery for use with your truck is composed of six or seven "sub-C" size cells with a rated capacity of between 1.2-1.8 amperes for one hour, or 2.4 amperes for 1/2 hour, etc. This charge capacity is the same regardless of the number of cells in the pack because the cells are connected in series and the same current passes through each one.

CHARGER. A good quality charger will last longer for you than an economy unit, so please do not cut yourself short here by trying to save a couple of dollars. Any good name brand charger will do the job correctly. The more sophisticated chargers have extra features that make charging less time-consuming and can easily handle the abuse of heavy back-to-back type charging. The choice of a DC only or an AC/DC charger should be based on personal needs (where you will be using your truck, etc.) and usage.

OVERCHARGE. There is no way to make a Ni-Cd cell accept more charge than it is designed to hold. This means that as the cell approaches a fully charged condition, the portion of charging current not being stored becomes heat and pressure. If charging continues after the cell is fully charged, all of the current is converted to heat and pressure—about 40 watts worth, or the equivalent of the heat produced by an average soldering iron. High temperature and pressure is damaging to the cells, so overcharging must be avoided.

Ni-Cd cells have a built-in process for recombining the accumulated gas (actually oxygen) produced by overcharge, but the process produces heat and takes a lot of time. If you overcharge your battery and it seems to take a long time to cool down, it's because this pressure reducing reaction is taking place. Once the gas is recombined the temperature drops.

HOW TO TELL WHEN YOUR CELLS ARE CHARGED

One of the problems with Ni-Cds is their inherent voltage stability; the voltage of a fully charged cell is not much different from one that's just about dead. For that reason several indicators, along with some common sense, are needed in order to get the most out of your battery. The following is a list of indicators you can use to detect full charge.

TEMPERATURE METHOD. This works only if you start with a cool battery pack. As the pack charges, frequently check its temperature by feeling the cells directly. As soon as you notice an increase in temperature, stop charging. If the cells become too hot to hold onto, your cells are excessively overcharged. Let them cool.

TIMED CHARGE METHOD. This works only if you have confidence in the timing accuracy of your charger. Many chargers on the market only approximate a constant charging current; they may vary from six amps when you first start charging, all the way down to two amps if the Ni-Cd pack is nearly charged and the voltage of the charging source (automobile battery) is low. If the charging current varies, it becomes difficult to estimate the average current. However, if your charger is reasonably dependable, you can use the following method.

Charge your pack using the "temperature method" above and keep track of the time required to reach full charge. Once you have established the time, you can use it as a setting for the timer on your charger. To be safe, use a setting about a minute less than what you established. This method allows you to charge without constantly monitoring the battery temperature.

If you charge a battery that is still hot from running, reduce the time about 20%. Then, after the pack has cooled, finish charging with the temperature method.

VOLTAGE METHOD. Voltage is a poor indication of a cell's state of charge. In fact, other factors like temperature, current drain, and "cell memory" have as much of an effect on voltage as the state of charge does. However, if current flow and temperature are held constant, it is possible to see the cell voltage gradually climb during the charging process. The absolute value of this voltage isn't of much use—how the voltage changes is an excellent indicator. To use this method, you will need a digital voltmeter or an expanded-scale voltmeter capable of resolving 0.01 volts on the 10 volt range.

Connect the voltmeter across the Ni-Cd pack, preferably right at the cell terminals, or, if that's not possible, across the terminals of the throttle control

resistor. Don't try to read the voltage at the output of the charger because you'll end up reading the voltage drop through all the connectors and cables between the charger and the Ni-Cd pack, which can sometimes distort the effect you're looking for. You should start with a Ni-Cd pack that is less than half charged. Connect your charger and begin charging at four amps. If your charger is adjustable, set the current now—but don't try to change it later. A constant current charger is preferable here, but if yours gradually drops off during charge, that's still permissible, as long as it doesn't drop below three amps.

Watch the voltage as the pack charges. Notice that the voltage at first climbs rapidly and in the middle of the charging cycle more slowly. This voltage will most likely be in the range of 8 1/2 to 9 volts for a six cell pack. As the pack approaches full charge, the voltage will begin to climb more rapidly; and as it goes into overcharge, the climb will slow down and then stop. This is where you stop charging—at the point where the voltage stops climbing. If you left the charger on, the voltage would begin to fall as the pack went deeply into overcharge and started to heat up. The maximum voltage reached will probably be in the nine to ten volt region; the actual value is unimportant.

When measuring voltage on NiCad cells, you must use a digital VOM (volt/ohm meter). A conventional analog scale VOM is not sensitive enough. By the time you see the needle move across the scale, you would have already damaged the battery cells.

SLOW CHARGE METHOD. Slow or "overnight" charging is a method you are not likely to use often, but it is a good way to bring the pack to absolutely full charge. However, the output voltage of a slow charged pack is slightly lower.

The charging current must be between 0.05 and 0.12 amperes. If less current, the pack will never reach full charge; any more and the pack will overheat. The time required to reach full charge ranges from 15 to 40 hours, depending on the current used. The charger can be left on for a much longer time without harming the cells; however, the output voltage of the pack will be temporarily lowered by an extremely long overcharge. The voltage returns to normal after a discharge-charge cycle.

These next two tips are really for the benefit of serious racers. If you're just out having fun, don't worry about them.

FULL DISCHARGE. Ni-Cd packs perform best if they are COMPLETELY discharged before they are charged. If you are involved in racing, you will have to do this if you expect to win any races! Discharge for at least an hour (preferably overnight with a clip-on resistor) before charging.

Associated Chargers have a discharge function. Various clip-on discharge resistors (about 30 ohms, 10 watts) are available at hobby stores.

TOPPING-UP can give you a little extra voltage at the beginning of a race, as long as you don't overdo it. Put the last minute or two of charge into your pack just before the race starts.

GOOD LUCK IN YOUR RACING!

CAUTION

Ni-cad batteries are susceptible to damage when overcharged at a high rate, and can release caustic chemicals if the overcharge is severe.

Do not stall the motor under power. If the truck stops suddenly on the track, or fails to move forward when you attempt to accelerate, push the throttle control on your transmitter to the brake position immediately and attend to the truck. A small rock can stall the gears, and if the throttle is left in the on position the result can be a burned out motor (or electronic speed control unit).

If you run your truck to the point where more than one cell in the pack is completely discharged, it is possible to lose radio control of the truck before the drive motor stops completely. For this reason you should not operate your truck in an area where it could be harmed or cause harm, such as near a busy roadway or a pool of water. Usually radio control will be regained as soon as you pick up the truck and the motor is allowed to free-run. If you still don't have control, then you should unplug the motor.

When you stop running your truck, turn off the radio at the truck first before turning off the transmitter.

A burned-out or shorted motor can make the truck appear to have radio problems. If the truck slows down suddenly and the radio acts erratically even with a full battery charge, then the cause is probably the motor. Check the range of the radio with the motor unplugged. A shorted motor will draw extremely high current even under no-load conditions.

SAVE THIS BOOKLET!

MORE THAN AN INSTRUCTION MANUAL, IT'S ALSO A HANDY, PICTORIAL SUPPLEMENT TO TEAM ASSOCIATED'S RC10T CATALOG.

REFER TO THIS MANUAL FOR PART NUMBER AND NAME WHEN ORDERING.