

Front Suspension:

RESET

Ride Height: 12mm - VS 5,1mm
 Camber: 2° - 26mm
 Toe: 1° - 21,9mm
 Anti-Roll Bar: 1,9 mm
 Arm Type: Carbon
 Tower Type: Kit
 Wheelbase Shim: hinter Schwinge
 Wheel Hex: 5mm
 Steering Block Type: Kit
 Caster Block: -2° -1° 0° +1° +2°
 Chassis Brace Material: Carbon
 Top Plate Brace Material: Kit
 Front Axles: CVA DCV
 Notes:

Lower Brace Type: Fixed Pivot



Ball Stud Spacing: 2mm

Arm Mount A: 1° 0.5°
 Gray Black



Arm Mount B: 1° 0.5°
 Gray Black



Diff Height:
 +3
 +2
 +1
 +0

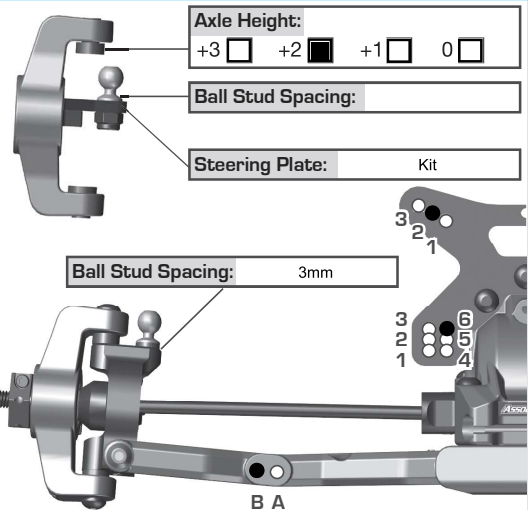

Rear Suspension:

Ride Height: 12mm - 5,2mm
 Camber: 2° - 31,2mm
 Anti-Roll Bar: 1,8mm
 Arm Type: Carbon
 Tower Type: Kit
 Wheelbase Shim: mittig
 Wheel Hex: 7mm
 Hub Type: Carbon HRC
 Drive Shaft Type: Universals
 Chassis Brace Material: Carbon
 Upper Chassis Brace Material: Carbon
 Hub Spacing: Fwd Mid Back
 Notes: Hub link mount 180° gedreht - Spurstange innen +3mm

Lower Brace Type: Fixed Pivot



Rear Chassis Brace Screws:

Arm Mount C: 1° 0.5°
 Gray Black



Arm Mount D: 1° 0.5°
 Gray Black



Axle Height:
 ▼0 3▲ +3
 ▼1 2▲ +2
 ▲1 2▼ +1
 ▲0 3▼ +0

Diff Height:
 +3
 +2
 +1
 +0

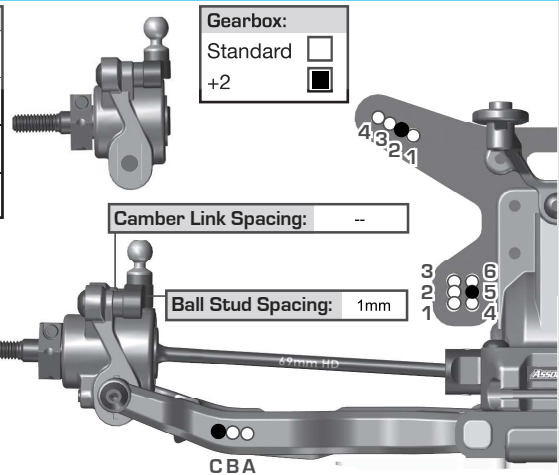

Electronics:

Radio: Sanwa M17 **Servo:** Ruddog 3008
 EPA: Throttle: % Brake: %
 ESC: Reedy Blackbox 610R
 ESC Settings:
 Motor / Wind: Reedy 4.5T **Timing:** 30°
 Pinion: 21 **Spur:** 78
 Motor Position: Forward Back
 Battery Position:
 Back 1 2 3 4 5 Forward
 Battery: Ruddog 5200 **Weight:**
 Notes:

Differential:

	Front	Center	Rear
Fluid:	AE60K		AE60K
Gears:	4		4
Type:	LTC		LTC
Notes:			

Slipper Clutch:

Type: decoupled Slipper 8,6mm
 # of Pads: Kit
 Setting: 2,7mm
 Notes:

Shocks:

	Front	Rear
Piston:	2x1.7	2x1.8
Thickness:	2mm	2mm
Fluid:	AE50WT	AE37.5WT
Spring:	Xray 4dot	Xray 4dot
Limiters:	Int: 2_ Ext: 5_	Int: 2_ Ext: 4_
Stroke:	21,6mm	27,5mm
Eyelet:	+2	0
Cup Offset:	0 <input type="checkbox"/> +5 <input checked="" type="checkbox"/> +9 <input type="checkbox"/>	0 <input type="checkbox"/> +5 <input type="checkbox"/> +9 <input type="checkbox"/>
Kashima Bodies:	<input checked="" type="checkbox"/>	Chrome Shafts: <input checked="" type="checkbox"/> Machined Spacers: <input checked="" type="checkbox"/>
Notes:	Dämpfer upside/down hinten+vorn	



Track Info:

Size:
 Surface: EOS Carpet
 Traction:
 Moisture:
 Condition:
 Temperature:
 Notes:

Tires:

Front Tires: Schumacher Shard
 Front Compound: gelb
 Front Insert: U6733
 Rear Tires: Schumacher Cactus
 Rear Compound: gelb
 Rear Insert: U6734
 Wheel (F/R): Ruddog
 Notes: Klebekante vorn bis auf Profil

Body, Weight:

Body: Kit
 Front Wing:
 Rear Wing: RDRP 6,5Zoll 1mm
 Rear Wing Mount: 0 -2
 Wing Angle: 0° 3° 6°
 Chassis Length: Kit
 Total Vehicle Weight:
 Notes:

Vehicle Comments:

Notes: Carbon Gearbox vorn+hinten
 RDRP Titanspurslangen
 RDRP Alulenkung (Arms+Rack)
 Carbon Sideguards
 RDRP A+B+C+D Block