

## Front Suspension:

RESET

Ride Height:	12 mm
Camber:	-1
Toe:	+1
Anti-Roll Bar:	1.8 mm
Arm Type:	#92128 Suspension Arm, Standard
Wheelbase Shim:	1 mm Behind Arm
Wheel Hex:	5 mm
Caster Block:	8° <input type="checkbox"/> 9° <input checked="" type="checkbox"/> 10° <input type="checkbox"/>
Chassis Brace:	Plastic <input checked="" type="checkbox"/> Carbon <input type="checkbox"/>
Top Plate Brace:	Yes <input type="checkbox"/> No <input checked="" type="checkbox"/>
Front Axles:	CVA <input type="checkbox"/> DCV <input checked="" type="checkbox"/>
Notes:	#92197 FT DCVs RDRP +4 mm Steering Rack



Front Chassis Brace Screws:

Ball Stud Spacing: 3 mm

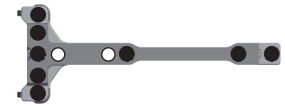

Arm Mount A: 1°  0.5°

Diff Height:
+3 <input type="checkbox"/>
+2 <input type="checkbox"/>
+1 <input type="checkbox"/>
0 <input type="checkbox"/>

Arm Mount B: 1°  0.5°

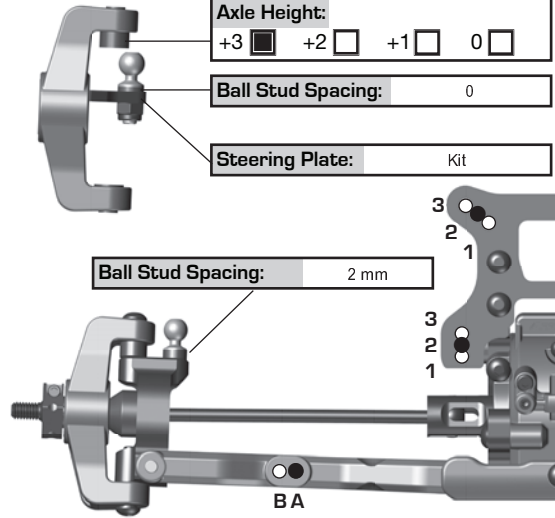

Axle Height:
+3 <input checked="" type="checkbox"/> +2 <input type="checkbox"/> +1 <input type="checkbox"/> 0 <input type="checkbox"/>

Ball Stud Spacing:	0
--------------------	---

Steering Plate:	Kit
-----------------	-----

Ball Stud Spacing: 2 mm

## Rear Suspension:

Ride Height:	12 mm
Camber:	-1
Anti-Roll Bar:	1.8mm
Arm Type:	#92130 Suspension Arm, Standard
Wheelbase Shim:	2 mm In Front Of Arm
Wheel Hex:	#71034 FT Clamping Wheel Hex, 6 mm
CVA Bone Length:	#92212 66 mm w/ #92207 Axles
Chassis Brace:	Plastic <input checked="" type="checkbox"/> Carbon <input type="checkbox"/>
Hub Spacing:	Fwd <input type="checkbox"/> Mid <input type="checkbox"/> Back <input checked="" type="checkbox"/>
Notes:	

Rear Chassis Brace Screws:

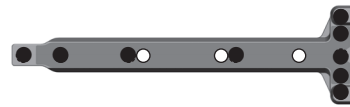

Arm Mount C: 1°  0.5°

Diff Height:
+3 <input type="checkbox"/>
+2 <input type="checkbox"/>
+1 <input type="checkbox"/>
0 <input type="checkbox"/>

Arm Mount D: 1°  0.5°

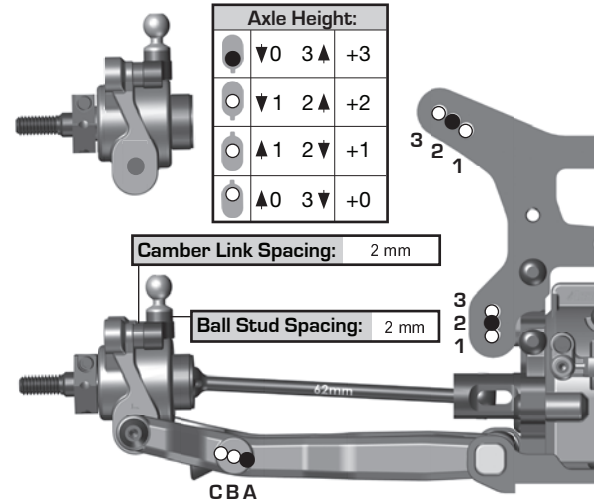

Axle Height:
▼0 3▲ +3
▼1 2▲ +2
▲1 2▼ +1
▲0 3▼ +0

Camber Link Spacing: 2 mm

Ball Stud Spacing: 2 mm

## Electronics:

Radio:	Sanwa	Servo:	#27101 Reedy RT1508
EPA: Throttle:	100 %	Brake:	85 %
ESC:	#27004 Reedy Blackbox 510R		
ESC Settings:	See Setup Sheet		
Motor:	Reedy Sonic M3		
Wind:	4.5	Timing:	20
Pinion:	18	Spur:	78
Battery:	#27349 Reedy Zapper SG3 LP 4100 mAh		
Battery Position:	1 <input type="checkbox"/> 2 <input type="checkbox"/> 3 <input type="checkbox"/> 4 <input checked="" type="checkbox"/>		

## Differential:

Front Fluid:	15k	Mass:	
Gears:	Plastic <input type="checkbox"/> Metal <input checked="" type="checkbox"/>		
Center Fluid:	N/A	Mass:	N/A
Gears:	Plastic <input type="checkbox"/> Metal <input type="checkbox"/>		
Rear Fluid:	15k	Mass:	
Gears:	Plastic <input type="checkbox"/> Metal <input checked="" type="checkbox"/>		
Slipper Clutch:			
Setting:	Tight		
Pads:	3 x #91197 FT LCF		

## Shocks:

	Front	Rear
Piston:	#91626 2x1.6 Flat Machined	#91627 2x1.7 Flat Machined
Fluid:	#5435 FT 50 wt	#5429 FT 35 wt
Spring:	#91835 Red V2	#91840 Blue V2
Limiters:	0 In / 3 Out	0 In / 4 Out
Stroke:	23 mm	29.5 mm
Eyelet Length:	Long	Long
Cup Offset:	9 mm	5 mm
Notes:	#91494 FT Machined Shock Spacers; #91493 FT X-Rings	

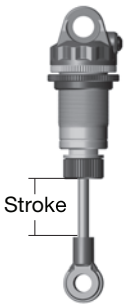

## Track Info:

Size:	Small <input type="checkbox"/> Medium <input type="checkbox"/> Large <input checked="" type="checkbox"/> Extra Large <input type="checkbox"/>
Surface:	Dirt <input type="checkbox"/> Carpet <input checked="" type="checkbox"/> AstroTurf <input type="checkbox"/> Multi Surface <input type="checkbox"/>
Traction:	Low <input type="checkbox"/> Medium <input type="checkbox"/> High <input type="checkbox"/> Very High <input type="checkbox"/>
Moisture:	Dry <input type="checkbox"/> Damp <input type="checkbox"/> Wet <input type="checkbox"/>
Condition:	Indoor <input checked="" type="checkbox"/> Outdoor <input type="checkbox"/> Dusty <input type="checkbox"/> Hard Packed <input type="checkbox"/> Bumpy <input type="checkbox"/> Grooved <input type="checkbox"/> Smooth <input type="checkbox"/> Loamy <input type="checkbox"/>
Temperature:	Ambient: _____ Track: _____
Notes:	

## Tires:

Front Tires:	JConcepts Swaggers
Front Compound:	Pink
Front Insert:	No Foam
Rear Tires:	JConcepts Twin Pin
Rear Compound:	Pink
Rear Insert:	JConcepts 4wd Front Foam
Wheel (F/R):	#92095 & #9695 Team Associated 12mm Hex
Notes:	

## Body, Wing, Weight:

Body:	JConcepts Finisher
Wing:	#91741 Team Associated Kit (No Vertical Wicker Bill)
Front Wing:	Yes <input type="checkbox"/> No <input checked="" type="checkbox"/>
Wing Angle:	0° <input type="checkbox"/> 6° <input checked="" type="checkbox"/>
Weights:	
Total Vehicle Weight:	

## Vehicle Comments:

Notes: To make the car slower reacting, use #91625 2 x 1.5 front pistons with #5430 FT 45 wt shock fluid and #91626 2 x 1.6 rear pistons with #5429 FT 35 wt shock fluid