

Front Suspension:

Ride Height:	13mm
Camber:	-1deg
Toe:	1deg
Anti-Roll Bar:	1.8mm
Arm Type:	Gull Wing - Standard
Tower Type:	Gull Wing
Wheelbase Shim:	1mm behind arm
Wheel Hex:	5.0mm
Caster Block:	8° <input type="checkbox"/> 9° <input checked="" type="checkbox"/> 10° <input type="checkbox"/>
Chassis Brace Support:	2mm G10
Top Plate Brace:	None
Front Axles:	CVA <input checked="" type="checkbox"/> DCV <input type="checkbox"/>
Notes:	_____

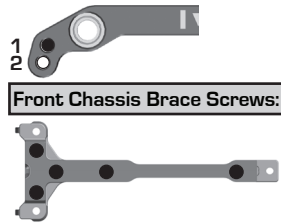

Front Chassis Brace Screws: _____

Ball Stud Spacing: 1mm

Arm Mount A: 1° 0.5°
 Gray Black



Arm Mount B: 1° 0.5°
 Gray Black



Diff Height:
 +2
 +0

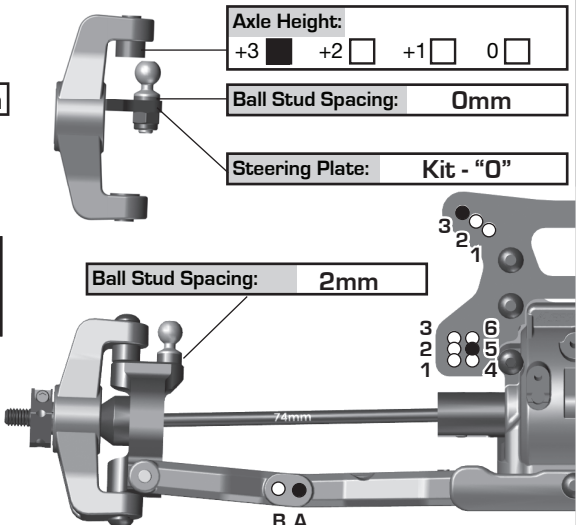

Rear Suspension:

Ride Height:	13mm
Camber:	-1deg
Anti-Roll Bar:	1.8mm
Arm Type:	Standard
Wheelbase Shim:	2mm in front of arm
Wheel Hex:	6.0mm
Chassis Brace Support:	2mm G10
Hub Spacing:	Fwd <input type="checkbox"/> Mid <input checked="" type="checkbox"/> Back <input type="checkbox"/>
Notes:	_____

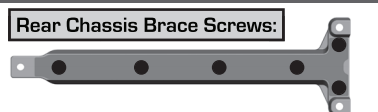

Rear Chassis Brace Screws: _____

Arm Mount C: 1° 0.5°
 Gray Black



Arm Mount D: 1° 0.5°
 Gray Black



Axle Height:

▼0	3▲	+3
▼1	2▲	+2
▲1	2▼	+1
▲0	3▼	+0

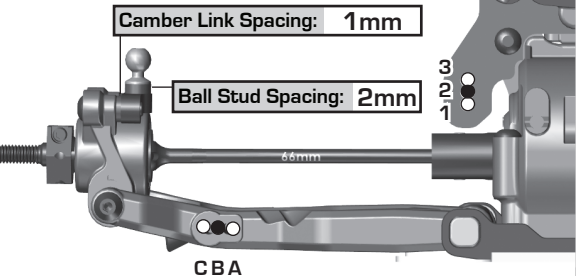

Electronics:

Radio:	Servo:
EPA: Throttle: %	Brake: %
ESC:	
ESC Settings:	
Motor / Wind:	Timing:
Pinion:	Spur: 78T
Battery:	
Battery Position:	
Back 1 <input type="checkbox"/> 2 <input type="checkbox"/> 3 <input type="checkbox"/> 4 <input checked="" type="checkbox"/> Forward	
Battery Weight:	

Differential:

	Front	Center	Rear
Fluid:	15K		15K
Gears:	Metal		Metal
Type:	LTC		LTC
Notes:	_____		

Slipper Clutch:

Type: Octalock 11mm LCF

of Pads: 2 Pad

Setting: 2.1mm

Shocks:

	Front	Rear
Piston:	2x1.6	2x1.7
Thickness:	2mm	2mm
Fluid:	45wt	35wt
Spring:	Red	Blue
Limiters:	Int: 1 Ext: 2	Int: ___ Ext: ___
Stroke:	22mm	27.5mm
Eyelet Length:	+2	0
Cup Offset:	5mm	0mm
Notes:	_____	

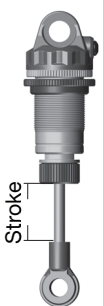

Track Info:

Size:	Small <input type="checkbox"/> Medium <input type="checkbox"/> Large <input type="checkbox"/> Extra Large <input type="checkbox"/>
Surface:	Dirt <input type="checkbox"/> Carpet <input type="checkbox"/> AstroTurf <input type="checkbox"/> Multi Surface <input type="checkbox"/>
Traction:	Low <input type="checkbox"/> Medium <input type="checkbox"/> High <input type="checkbox"/> Very High <input type="checkbox"/>
Moisture:	Dry <input type="checkbox"/> Damp <input type="checkbox"/> Wet <input type="checkbox"/>
Condition:	Indoor <input type="checkbox"/> Outdoor <input type="checkbox"/> Dusty <input type="checkbox"/> Hard Packed <input type="checkbox"/> Bumpy <input type="checkbox"/> Grooved <input type="checkbox"/> Smooth <input type="checkbox"/> Loamy <input type="checkbox"/>
Temperature:	Ambient: _____ Track: _____
Notes:	_____
Vehicle Comments:	_____

Tires:

Front Tires:	_____
Front Compound:	_____
Front Insert:	_____
Rear Tires:	_____
Rear Compound:	_____
Rear Insert:	_____
Wheel (F/R):	_____
Notes:	_____

Body, Wing, Weight:

Body:	Kit - Lightweight
Front Wing:	Yes <input type="checkbox"/> No <input checked="" type="checkbox"/>
Rear Wing:	Kit
Wing Angle:	0° <input type="checkbox"/> 6° <input checked="" type="checkbox"/>
Wing Mount Height:	0 <input type="checkbox"/> -2 <input checked="" type="checkbox"/>
Servo Weights:	_____
Electronic Weights:	_____
Total Vehicle Weight:	_____