

Front Suspension

Ride Height: \_\_\_\_\_  
 Camber: \_\_\_\_\_  
 Toe: \_\_\_\_\_  
 Anti-Roll Bar: \_\_\_\_\_  
 Arm Type: \_\_\_\_\_  
 Tower Type: \_\_\_\_\_  
 Wheelbase Shim: \_\_\_\_\_  
 Wheel Hex: \_\_\_\_\_  
 Caster Block: 8°  9°  10°   
 Chassis Brace Support: \_\_\_\_\_  
 Top Plate Brace: \_\_\_\_\_  
 Front Axles: CVA  DCV

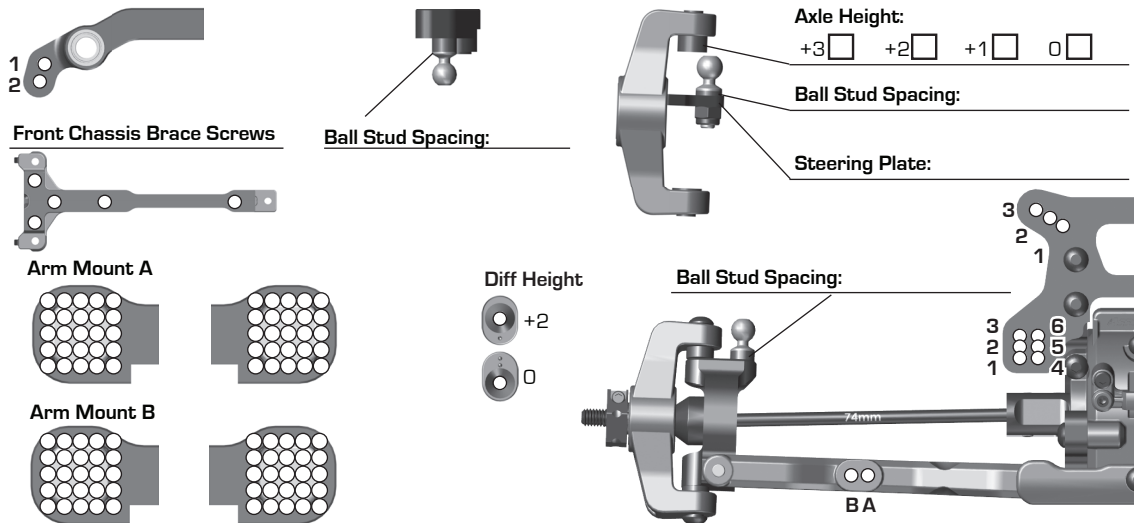

Notes

Rear Suspension

Ride Height: \_\_\_\_\_  
 Camber: \_\_\_\_\_  
 Anti-Roll Bar: \_\_\_\_\_  
 Arm Type: \_\_\_\_\_  
 Wheelbase Shim: \_\_\_\_\_  
 Wheel Hex: \_\_\_\_\_  
 CVA Bone Length: \_\_\_\_\_  
 Chassis Brace Support: \_\_\_\_\_  
 Hub Spacing: Fwd  Mid  Back

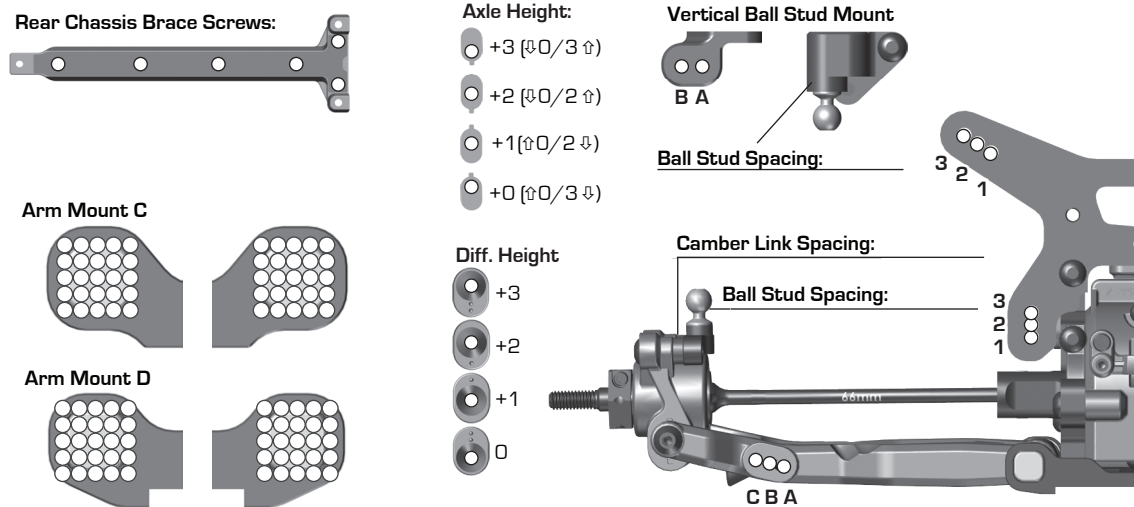

Notes

Electronics, Drivetrain

Radio: \_\_\_\_\_ Servo: \_\_\_\_\_  
 EPA: Throttle: \_\_\_\_\_ % Brake: \_\_\_\_\_ %  
 ESC: \_\_\_\_\_  
 ESC Settings: \_\_\_\_\_  
 Motor: \_\_\_\_\_ Timing: \_\_\_\_\_  
 Pinion: \_\_\_\_\_ Spur: \_\_\_\_\_  
 Battery: Back 1  2  3  4  Fwd  
 Battery Position: \_\_\_\_\_

Diffs	Front	Center	Rear
Fluid			
Gears			
Type			

Notes

Slipper Clutch: \_\_\_\_\_  
 # of Pads \_\_\_\_\_

Shocks	Front	Rear
Piston:		
Fluid:		
Spring:		
Limiters:	Int: _____ Ext: _____	Int: _____ Ext: _____
Stroke:		
Eyelet Length:		
Cup Offset:		

Notes



Track Info, Tires & Aero

Layout: Tight  Mixed  Open  Extra Large   
 Surface: Dirt  Carpet  Astroturf   
 Traction: Low  Medium  High  Very High   
 Moisture: Dry  Damp  Wet   
 Condition: Indoor  Outdoor  Dusty  Hard Packed   
 Bumpy  Grooved  Smooth  Loamy   
 Temperature: Ambient: \_\_\_\_\_ Humidity: \_\_\_\_\_

Notes

Front Tires: \_\_\_\_\_  
 Front Compound: \_\_\_\_\_  
 Front Insert: \_\_\_\_\_  
 Rear Tires: \_\_\_\_\_  
 Rear Compound: \_\_\_\_\_  
 Rear Insert: \_\_\_\_\_  
 Wheel (F/R): \_\_\_\_\_

Notes

Body: \_\_\_\_\_  
 Rear Wing: \_\_\_\_\_  
 Wing Angle: 0°  6°   
 Wing Mount Height: 0  -2   
 Front Wing Yes  No   
 Servo Weights: \_\_\_\_\_  
 Electronic Weights: \_\_\_\_\_  
 Total Vehicle Weight: \_\_\_\_\_

Comments