

Front Suspension:

Reset Forms

Ride Height: 17mm
 Camber: -1*
 Toe: Full droop, slight toe out
 Anti-Roll Bar: None
 Arm Type: Kit
 Tower Type: Kit
 Wheel Hex: Kit
 Steering Block KPI: 2
 Caster Block Insert: 0 +2.5 +5
 Bulkhead Type: 0* aluminum
 Kick-Up Angle: -2.5 0 +2.5
 Steering Stop Spacing: Remove screw
 Caster Block Spacing: Fwd Back
 Notes: add shim steering link until link is straight

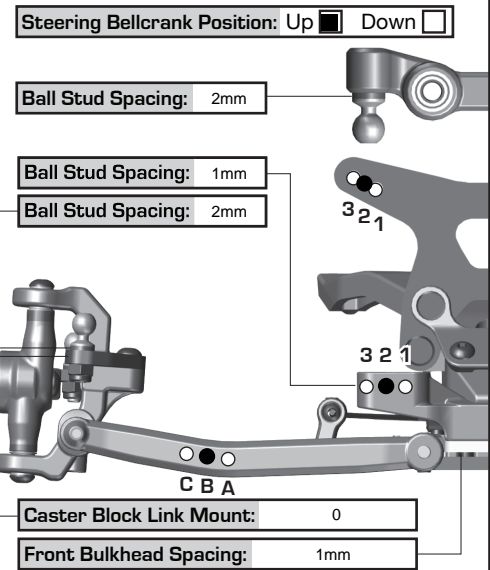
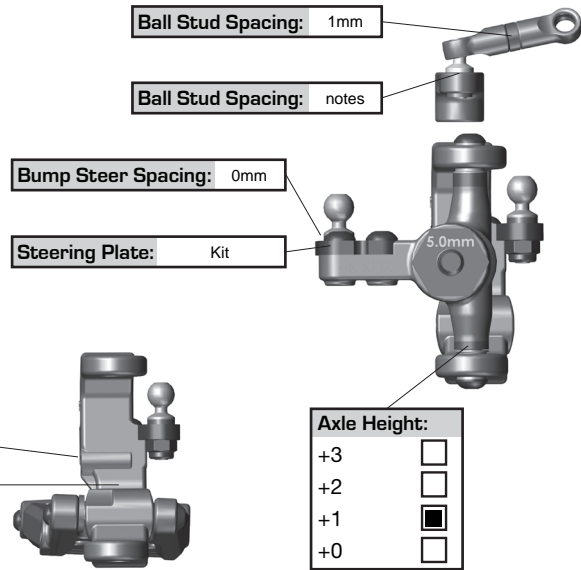

Rear Suspension:

Ride Height: 17mm
 Camber: -1*
 Anti-Roll Bar: None
 Arm Type: Kit
 Tower Type: Kit
 Arm Spacing: Fwd Mid Back
 Wheel Hex:
 Hub Type: Std HRC
 Hub Spacing: Fwd Mid Back
 Drive Shaft: CVA's Universals
 Notes:

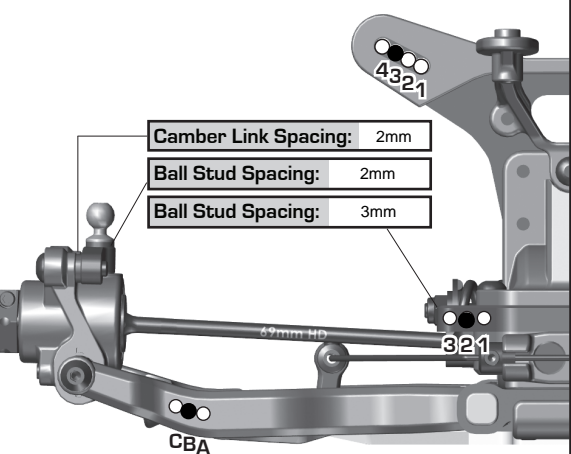
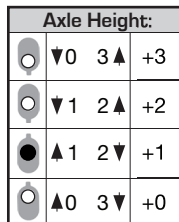
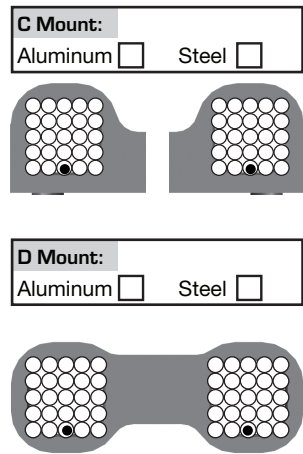

Electronics:

Radio: Noble NB4 Servo: Savox 1258tg
 EPA: Throttle: 100 % Brake: 100 %
 ESC: Reedy 510r
 ESC Settings: Who cares lol
 Motor / Wind: MC4 17.5 Timing: 46.5
 Pinion: 32t Spur: 72t
 Battery Mount: Std Offset
 Battery: Reedy zapper 6400 Weight: none
 Notes:

Drivetrain:

Differential: Ball Diff:
 Height: 1 Gear Diff:
 Diff Setting: yes
 Notes:

Slipper Clutch:

Type:
 # of Pads:
 Setting:
 Notes:

Shocks:

	Front	Rear
Piston:	2x1.8	2x1.9
Thickness:	2.5mm	2.5mm
Fluid:	30wt	30wt
Spring:	1up red	1up gold
Limiters:	Int: 0 Ext: 0	Int: 0 Ext: 0
Stroke:	23	28
Eyelet:	2	4
Cup Offset:	0 <input type="checkbox"/> +5 <input checked="" type="checkbox"/> +9 <input type="checkbox"/>	0 <input type="checkbox"/> +5 <input type="checkbox"/> +9 <input type="checkbox"/>
Kashima Bodies:	<input type="checkbox"/>	Chrome Shafts: <input type="checkbox"/> Machined Spacers: <input type="checkbox"/>
Notes:		

Track Info:

Size: small-medium
 Surface: hard packed dirt
 Traction: high
 Moisture: mid
 Condition: blown every run, or often enough
 watered almost every round
 Temperature:
 Notes:

Tires:

Front Tires: JC Smoothie 2s
 Front Compound: Silver
 Front Insert: Dirt-tech
 Rear Tires: JC Smoothie 2s
 Rear Compound: Silver
 Rear Insert: Dirt-tech
 Wheel (F/R): JC Mono
 Notes: Sauce 5min before run, wipe, no wait

Body, Weight:

Body: Team associated B7 body
 Front Wing: No
 Rear Wing: JC Turf wing
 Wing Angle: 0° 3° 6°
 Chassis Length:
 Servo Weights:
 Electronic Weights: 11g
 Total Vehicle Weight:

Vehicle Comments:

Notes: