

Front Suspension:

Ride Height: _____
 Camber: _____
 Toe: _____
 Anti-Roll Bar: _____
 Arm Type: _____
 Tower Type: _____
 Wheel Hex: _____
 Steering Block KPI: _____
 Caster Block Insert: 0 +2.5 +5
 Bulkhead Type: _____
 Kick-Up Angle: -2.5 0 +2.5
 Steering Stop Spacing: _____
 Caster Block Spacing: Fwd Back
 Notes: _____

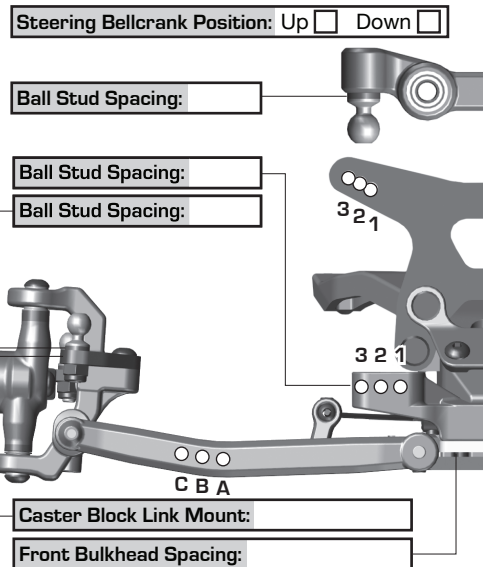
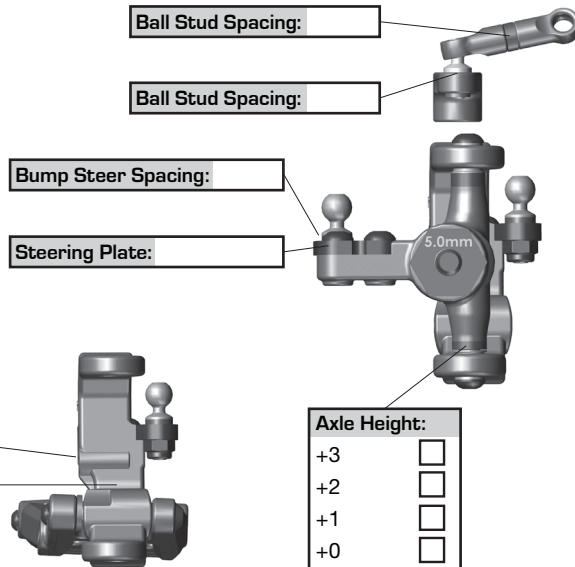

Rear Suspension:

Ride Height: _____
 Camber: _____
 Anti-Roll Bar: _____
 Arm Type: _____
 Tower Type: _____
 Arm Spacing: Fwd Mid Back
 Wheel Hex: _____
 Hub Type: Std HRC
 Hub Spacing: Fwd Mid Back
 Drive Shaft: CVA's Universals
 Notes: _____

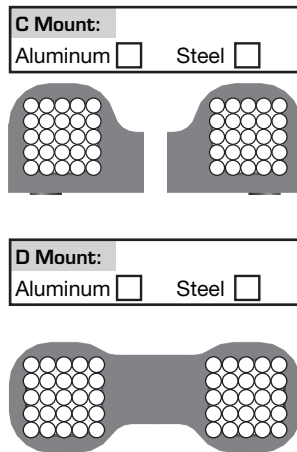

Axle Height:	
<input type="radio"/> ▼0 3 ▲	+3
<input type="radio"/> ▼1 2 ▲	+2
<input type="radio"/> ▲1 2 ▼	+1
<input type="radio"/> ▲0 3 ▼	+0

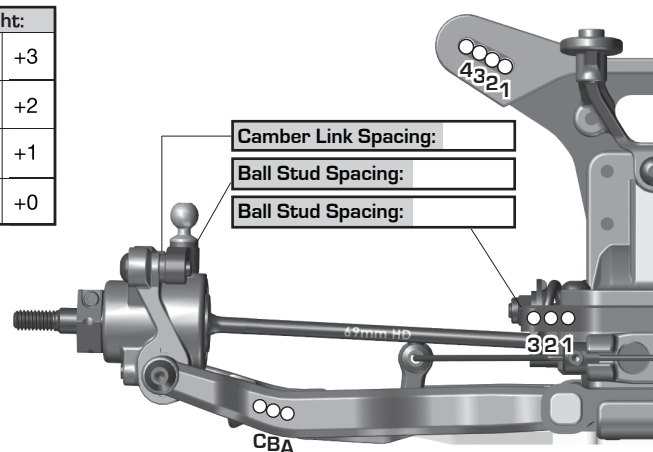

Electronics:

Radio: _____ Servo: _____
 EPA: Throttle: _____ % Brake: _____ %
 ESC: _____
 ESC Settings: _____
 Motor / Wind: _____ Timing: _____
 Pinion: _____ Spur: _____
 Battery Mount: Std Offset
 Back 1 2 3 4 5 Forward
 Battery: _____ Weight: _____
 Notes: _____

Drivetrain:

Differential: Ball Diff:
 Height: _____ Gear Diff:
 Diff Setting: _____
 Notes: _____

Slipper Clutch:

Type: _____
 # of Pads: _____
 Setting: _____
 Notes: _____

Shocks:

	Front	Rear
Piston:	_____	_____
Thickness:	_____	_____
Fluid:	_____	_____
Spring:	_____	_____
Limiters: Int: _____ Ext: _____	Int: _____ Ext: _____	Int: _____ Ext: _____
Stroke:	_____	_____
Eyelet:	_____	_____
Cup Offset: 0 <input type="checkbox"/> +5 <input type="checkbox"/> +9 <input type="checkbox"/>	0 <input type="checkbox"/> +5 <input type="checkbox"/> +9 <input type="checkbox"/>	0 <input type="checkbox"/> +5 <input type="checkbox"/> +9 <input type="checkbox"/>
Kashima Bodies: <input type="checkbox"/>	Chrome Shafts: <input type="checkbox"/>	Machined Spacers: <input type="checkbox"/>
Notes:	_____	_____

Track Info:

Size: _____
 Surface: _____
 Traction: _____
 Moisture: _____
 Condition: _____
 Temperature: _____
 Notes: _____

Tires:

Front Tires: _____
 Front Compound: _____
 Front Insert: _____
 Rear Tires: _____
 Rear Compound: _____
 Rear Insert: _____
 Wheel (F/R): _____
 Notes: _____

Body, Weight:

Body: _____
 Front Wing: _____
 Rear Wing: _____
 Wing Angle: 0° 3° 6°
 Chassis Length: _____
 Servo Weights: _____
 Electronic Weights: _____
 Total Vehicle Weight: _____

Vehicle Comments:

Notes: _____

