



Driver: Team Event: N/A Qualify: N/A Main: N/A
 Date: December 29, 2023 Tracks: TR Speedway Finish: N/A Best Lap Time: N/A

Front Suspension:

Reset Forms

Ride Height:	13mm
Camber:	-1.5°
Toe:	0° (Tierod Gap = 27.5mm)
Anti-Roll Bar:	1.0mm
Arm Type:	#92411 FT Carbon
Tower Type:	#92430 Kit
Wheel Hex:	#91610 FT Clamping, 7.0mm
Steering Block KPI:	#92414 Kit - 4 Trail / KPI 3
Caster Block Insert:	0 <input type="checkbox"/> -2.5 <input checked="" type="checkbox"/> -5 <input type="checkbox"/>
Bulkhead Type:	#92436 FT 0°, Aluminum
Kick-Up Angle:	-2.5 <input type="checkbox"/> 0 <input checked="" type="checkbox"/> +2.5 <input type="checkbox"/>
Steering Stop Spacing:	0mm
Caster Block Spacing:	Fwd <input type="checkbox"/> Back <input type="checkbox"/>
Notes:	#71181 FT Hex Adapter Front Axles, Titanium #91983 FT Steering Bellcranks, Aluminum

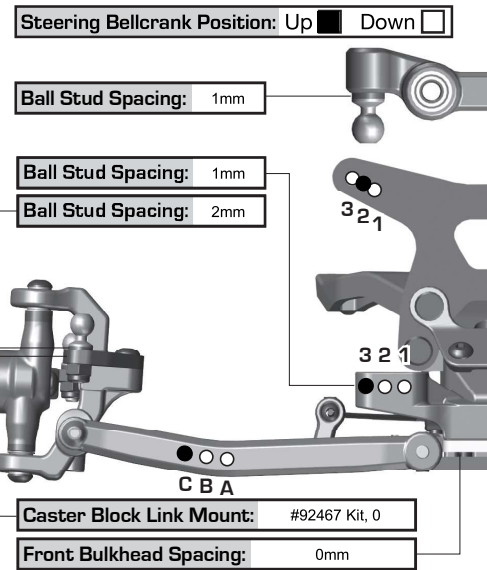
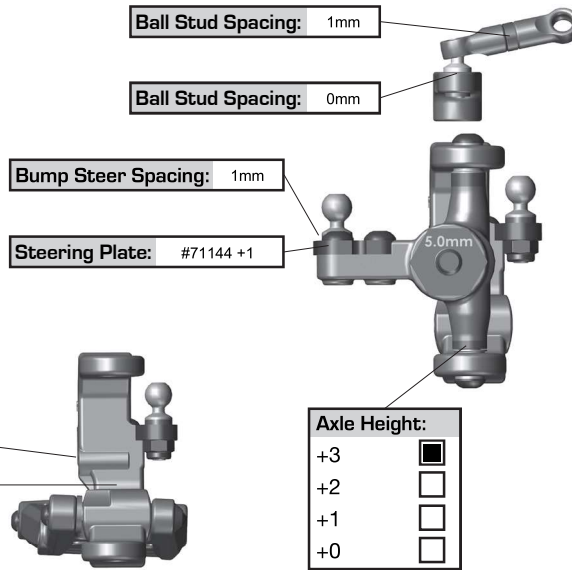

Rear Suspension:

Ride Height:	13mm
Camber:	-1.5°
Anti-Roll Bar:	1.0mm
Arm Type:	#92409 FT Carbon
Tower Type:	#92431 Kit
Arm Spacing:	Fwd <input type="checkbox"/> Mid <input type="checkbox"/> Back <input type="checkbox"/>
Wheel Hex:	#91609 FT Clamping, 5.0mm
Hub Type:	Std <input type="checkbox"/> HRC <input checked="" type="checkbox"/> #92413 FT Carbon
Hub Spacing:	Fwd <input type="checkbox"/> Mid <input checked="" type="checkbox"/> Back <input type="checkbox"/>
Drive Shaft:	CVA's <input checked="" type="checkbox"/> Universals <input type="checkbox"/>
Notes:	#92185 FT Carbon Hub Link Shims

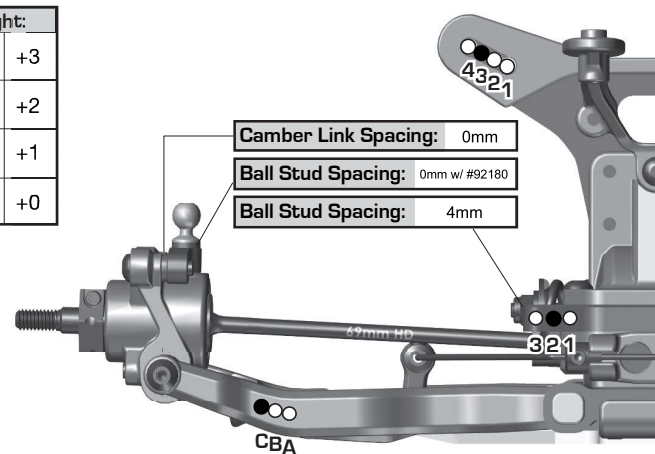
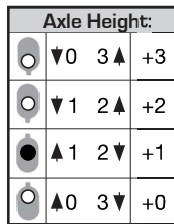
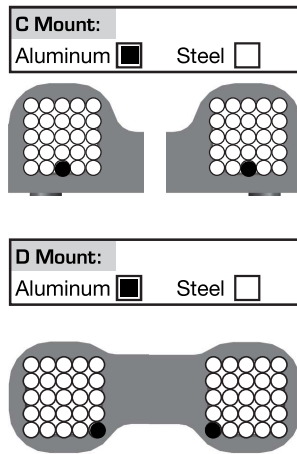

Electronics:

Radio:	N/A	Servo:	#27119 Reedy RT1705A
EPA: Throttle:	N/A %	Brake:	N/A %
ESC:	#27017 Reedy Blackbox 610R		
ESC Settings:	See Setup Sheet		
Motor / Wind:	#27444 Reedy Sonic M4 6.5T	Timing:	20°
Pinion:	#1341 FT 23T	Spur:	#92296 Octalock 81T
Battery Mount:	Std <input type="checkbox"/> Offset <input checked="" type="checkbox"/>	Forward	
Battery:	#27396 Reedy Zapper 4800	Weight:	#27355 Reedy Battery Weight, 50g
Notes:	#1370 FT Servo Horn, 25T (2mm Ballstud Spacing)		

Drivetrain:

Differential:	Ball Diff: <input type="checkbox"/>
Height:	1 Gear Diff: <input checked="" type="checkbox"/>
Diff Setting:	#91918 FT Diff Decoder = 205 #5459 FT 100k
Notes:	4-Gear LTC Metal

Slipper Clutch:

Type:	#92450 & 91803 Kit
# of Pads:	#92285 FT Octalock LCF x 2
Setting:	Front Tires Lift 1"
Notes:	

Shocks:

	Front	Rear
Piston:	2 x 1.6	2 x 1.9
Thickness:	#91932 2.5mm	#92428 2.5mm
Fluid:	#5474 FT 35wt	#5472 FT 30wt
Spring:	#91944 13mm Red	#91950 13mm Blue
Limiters:	Int: 0 Ext: 1mm	Int: 0 Ext: 2mm
Stroke:	23.5mm	27.5mm
Eyelet:	0mm	+2mm
Cup Offset:	0 <input type="checkbox"/> +5 <input checked="" type="checkbox"/> +9 <input type="checkbox"/>	0 <input type="checkbox"/> +5 <input type="checkbox"/> +9 <input type="checkbox"/>
Kashima Bodies:	<input checked="" type="checkbox"/>	Chrome Shafts: <input checked="" type="checkbox"/> Machined Spacers: <input checked="" type="checkbox"/>
Notes:		

Track Info:

Size:	Medium
Surface:	CRC Black Carpet
Traction:	High
Moisture:	None
Condition:	High Speed Sweepers; Technical Infield
Temperature:	70F
Notes:	

Tires:

Front Tires:	JConcepts Fuzzbites
Front Compound:	Double Pink
Front Insert:	None
Rear Tires:	JConcepts Fuzzbites
Rear Compound:	Double Pink
Rear Insert:	JConcepts Open Cell Gray
Wheel (F/R):	#9690 & 9695 Team Associated 12mm
Notes:	

Body, Weight:

Body:	#92423 FT Lightweight RC10B7
Front Wing:	#92425 Team Associated RC10B7
Rear Wing:	#92424 Team Associated RC10B7 7"
Wing Angle:	0° <input type="checkbox"/> 3° <input type="checkbox"/> 6° <input checked="" type="checkbox"/>
Chassis Length:	#92400 RC10B7
Servo Weights:	None
Electronic Weights:	#91977 FT Aluminum
Total Vehicle Weight:	N/A

Vehicle Comments:

Notes:	#92360 FT Titanium Turnbuckle Set #91750, 91751, 91752 & 91753 FT Titanium Ballstuds
--------	---