

**Front Suspension:**

Ride Height: \_\_\_\_\_  
Camber: \_\_\_\_\_  
Toe: \_\_\_\_\_  
Anti-Roll Bar: \_\_\_\_\_  
Arm Type: \_\_\_\_\_  
Tower Type: \_\_\_\_\_  
Wheel Hex: \_\_\_\_\_  
Steering Block KPI: \_\_\_\_\_  
Caster Block Insert: 0  +2.5  +5   
Bulkhead Type: \_\_\_\_\_  
Kick-Up Angle: -2.5  0  +2.5   
Steering Stop Spacing: \_\_\_\_\_  
Caster Block Spacing: Fwd  Back   
Notes: \_\_\_\_\_

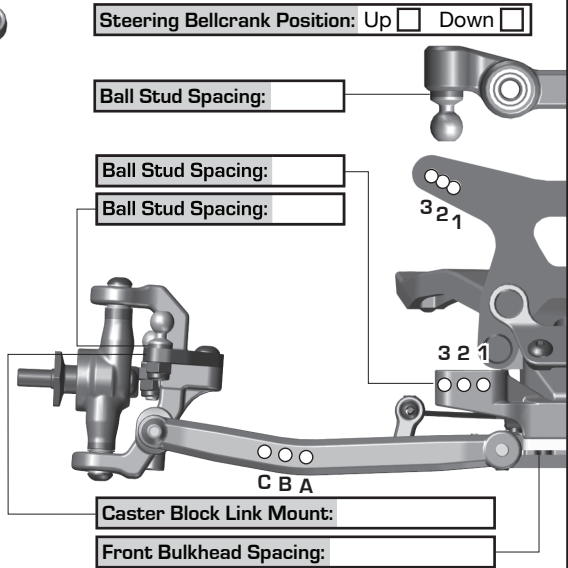
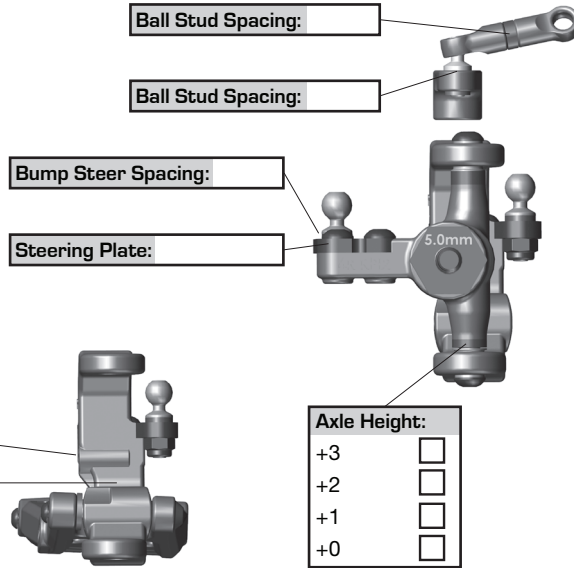

**Rear Suspension:**

Ride Height: \_\_\_\_\_  
Camber: \_\_\_\_\_  
Anti-Roll Bar: \_\_\_\_\_  
Arm Type: \_\_\_\_\_  
Tower Type: \_\_\_\_\_  
Arm Spacing: Fwd  Mid  Back   
Wheel Hex: \_\_\_\_\_  
Hub Type: Std  HRC   
Hub Spacing: Fwd  Mid  Back   
Drive Shaft: CVA's  Universals   
Notes: \_\_\_\_\_

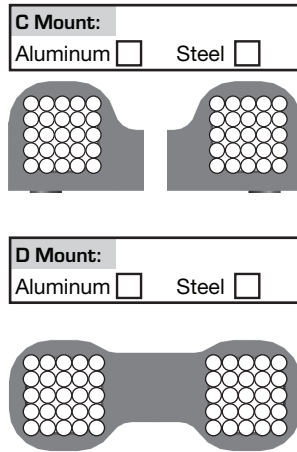

Axle Height:	
<input type="radio"/> ▼0 3 ▲	+3
<input type="radio"/> ▼1 2 ▲	+2
<input type="radio"/> ▲1 2 ▼	+1
<input type="radio"/> ▲0 3 ▼	+0

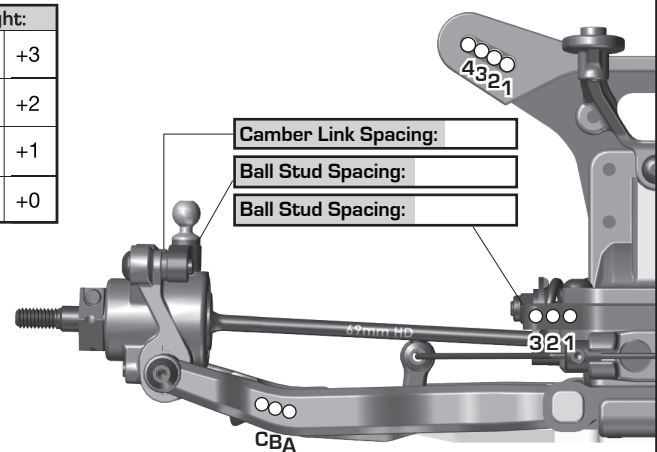

**Electronics:**

Radio: \_\_\_\_\_ Servo: \_\_\_\_\_  
EPA: Throttle: \_\_\_\_\_ % Brake: \_\_\_\_\_ %  
ESC: \_\_\_\_\_  
ESC Settings: \_\_\_\_\_  
Motor / Wind: \_\_\_\_\_ Timing: \_\_\_\_\_  
Pinion: \_\_\_\_\_ Spur: \_\_\_\_\_  
Battery Mount: Std  Offset   
Back 1  2  3  4  5  Forward  
Battery: \_\_\_\_\_ Weight: \_\_\_\_\_  
Notes: \_\_\_\_\_

**Drivetrain:**

Differential: Ball Diff:   
Height: \_\_\_\_\_ Gear Diff:   
Diff Setting: \_\_\_\_\_  
Notes: \_\_\_\_\_

**Slipper Clutch:**

Type: \_\_\_\_\_  
# of Pads: \_\_\_\_\_  
Setting: \_\_\_\_\_  
Notes: \_\_\_\_\_

**Shocks:**

	Front	Rear
Piston:	_____	_____
Thickness:	_____	_____
Fluid:	_____	_____
Spring:	_____	_____
Limiters: Int: _____ Ext: _____	Int: _____ Ext: _____	Int: _____ Ext: _____
Stroke:	_____	_____
Eyelet:	_____	_____
Cup Offset: 0 <input type="checkbox"/> +5 <input type="checkbox"/> +9 <input type="checkbox"/> 0 <input type="checkbox"/> +5 <input type="checkbox"/> +9 <input type="checkbox"/>		
Kashima Bodies: <input type="checkbox"/> Chrome Shafts: <input type="checkbox"/> Machined Spacers: <input type="checkbox"/>		
Notes:		

Stroke

**Track Info:**

Size: \_\_\_\_\_  
Surface: \_\_\_\_\_  
Traction: \_\_\_\_\_  
Moisture: \_\_\_\_\_  
Condition: \_\_\_\_\_  
Temperature: \_\_\_\_\_  
Notes: \_\_\_\_\_

**Tires:**

Front Tires: \_\_\_\_\_  
Front Compound: \_\_\_\_\_  
Front Insert: \_\_\_\_\_  
Rear Tires: \_\_\_\_\_  
Rear Compound: \_\_\_\_\_  
Rear Insert: \_\_\_\_\_  
Wheel (F/R): \_\_\_\_\_  
Notes: \_\_\_\_\_

**Body, Weight:**

Body: \_\_\_\_\_  
Front Wing: \_\_\_\_\_  
Rear Wing: \_\_\_\_\_  
Wing Angle: 0°  3°  6°   
Chassis Length: \_\_\_\_\_  
Servo Weights: \_\_\_\_\_  
Electronic Weights: \_\_\_\_\_  
Total Vehicle Weight: \_\_\_\_\_

**Vehicle Comments:**

Notes: \_\_\_\_\_  
\_\_\_\_\_  
\_\_\_\_\_  
\_\_\_\_\_  
\_\_\_\_\_