

## Front Suspension:

**Ride Height:** \_\_\_\_\_  
**Camber:** \_\_\_\_\_  
**Toe:** \_\_\_\_\_  
**Arm Type:** \_\_\_\_\_  
**Tower Type:** \_\_\_\_\_  
**Caster Block Insert:** \_\_\_\_\_  
**Bulkhead Type:** \_\_\_\_\_  
**Kick-Up Angle:** \_\_\_\_\_  
**Wheel Hex:** \_\_\_\_\_  
**Notes:** \_\_\_\_\_  
 \_\_\_\_\_  
 \_\_\_\_\_  
 \_\_\_\_\_

**Anti Roll Bar:**  
 None   
 White (0.8mm)   
 Gray (0.9mm)   
 Blue (1.0mm)   
 Other: \_\_\_\_\_

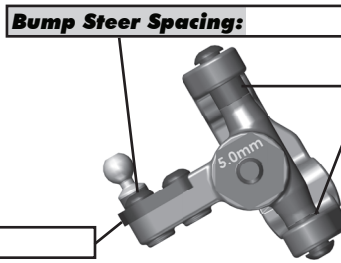

**Axle Height:**  
 +3   
 +2   
 +1   
 0

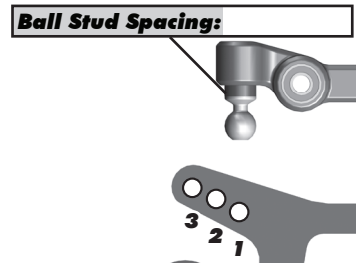

**Steering Plate:** \_\_\_\_\_

**Steering Stop Spacing:** \_\_\_\_\_

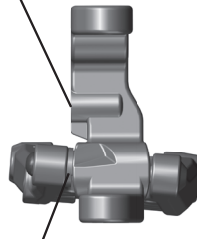

**Caster Block Spacing:** \_\_\_\_\_

**Ball Stud Spacing:** \_\_\_\_\_

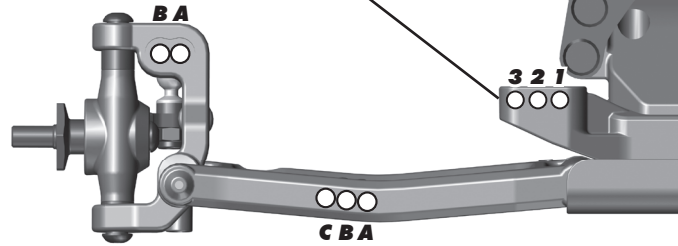

## Rear Suspension:

**Ride Height:** \_\_\_\_\_  
**Camber:** \_\_\_\_\_  
**Wheel Hex:** \_\_\_\_\_  
**Hub Spacing:**  
 Forward  Middle  Back   
**Shock Mounting Position:**  
 Front of Arm  Rear of Arm   
**Notes:** \_\_\_\_\_  
 \_\_\_\_\_  
 \_\_\_\_\_

**Anti Roll Bar:**  
 None   
 White (1.2mm)   
 Gray (1.3mm)   
 Blue (1.4mm)   
 Other: \_\_\_\_\_

**Rear Hub Link Setting:**  
**Up**  
 E C A  
 D B  
**Down**  
 D B  
 E C A

**C Mount Inserts:** 1°  0.5°



**D Mount Inserts:** 1°  0.5°



**Hub Insert:**  
 +3  +2  +1  0

**Ball Stud Spacing:** \_\_\_\_\_

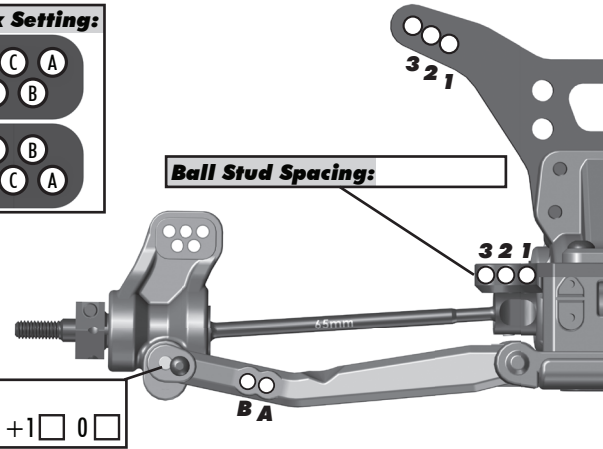

## Electronics:

**Radio:** \_\_\_\_\_ **Servo:** \_\_\_\_\_  
**EPA:** Throttle: \_\_\_\_\_ % Brake: \_\_\_\_\_ %  
**ESC:** \_\_\_\_\_  
**ESC Settings:** \_\_\_\_\_  
**Motor:** \_\_\_\_\_  
**Wind:** \_\_\_\_\_ **Timing:** \_\_\_\_\_  
**Pinion:** \_\_\_\_\_ **Spur:** \_\_\_\_\_  
**Battery:** \_\_\_\_\_  
**Battery Position:** \_\_\_\_\_

## Drivetrain:

**Transmission:**  
**3 Gear:**  **4 Gear:**   
**Stand Up:**  **Lay Down:**   
**Differential:**  
**Ball Diff:**  **Gear Diff:**   
**Notes:** \_\_\_\_\_  
**Slipper Clutch:**  
**Type:** \_\_\_\_\_  
**# of Pads:** \_\_\_\_\_

## Shocks:

	Front	Rear
<b>Piston:</b>	_____	_____
<b>Fluid:</b>	_____	_____
<b>Spring:</b>	_____	_____
<b>Limiters:</b>	_____	_____
<b>Stroke:</b>	_____	_____
<b>Eyelet Length:</b>	_____	_____
<b>Cup Offset:</b>	_____	_____
<b>Notes:</b>	_____	_____



## Track Info:

**Size:** Small  Medium  Large  Extra Large   
**Surface:** Dirt  Carpet  Astroturf  Multi Surface   
**Traction:** Low  Medium  High  Very High   
**Moisture:** Dry  Damp  Wet   
**Condition:** Indoor  Outdoor  Dusty  Hard Packed   
 Bumpy  Grooved  Smooth  Loamy   
**Temperature:** Ambient: \_\_\_\_\_ Track: \_\_\_\_\_  
**Notes:** \_\_\_\_\_

## Tires:

**Front Tires:** \_\_\_\_\_  
**Front Compound:** \_\_\_\_\_  
**Front Insert:** \_\_\_\_\_  
**Rear Tires:** \_\_\_\_\_  
**Rear Compound:** \_\_\_\_\_  
**Rear Insert:** \_\_\_\_\_  
**Wheel (F/R):** \_\_\_\_\_  
**Notes:** \_\_\_\_\_

## Body, Wing, Weight:

**Body:** \_\_\_\_\_  
**Wing:** \_\_\_\_\_  
**Wing Angle:** 0°  3°  6°   
**Servo Weights:**  
 None  Aluminum  Steel  Other   
**Electronic Weights:**  
 None  Aluminum  Steel  Other   
**Total Vehicle Weight:** \_\_\_\_\_

## Vehicle Comments:

**Notes:** \_\_\_\_\_