

Front Suspension:

Ride Height:	21mm
Camber:	-1°
Toe:	0 deg
Anti-Roll Bar:	
Arm Type:	#91673 Gull-Wing, Standard
Tower Type:	#91880 Gull-Wing
Caster Block Insert:	5°
Steering Block:	4mm
Bulkhead Type:	#91656 Plastic
Kick-Up Angle:	25°
Wheel Hex:	#91682 Aluminum, 5mm
Notes:	

Bump Steer Spacing: 0mm

Steering Plate: #71144 +1

Steering Stop Spacing: 0mm

Caster Block Spacing: 1mm

Axle Height:

+3	<input type="checkbox"/>
+2	<input checked="" type="checkbox"/>
+1	<input type="checkbox"/>
0	<input type="checkbox"/>

Ball Stud Spacing: 1mm

Ball Stud Spacing: 1mm

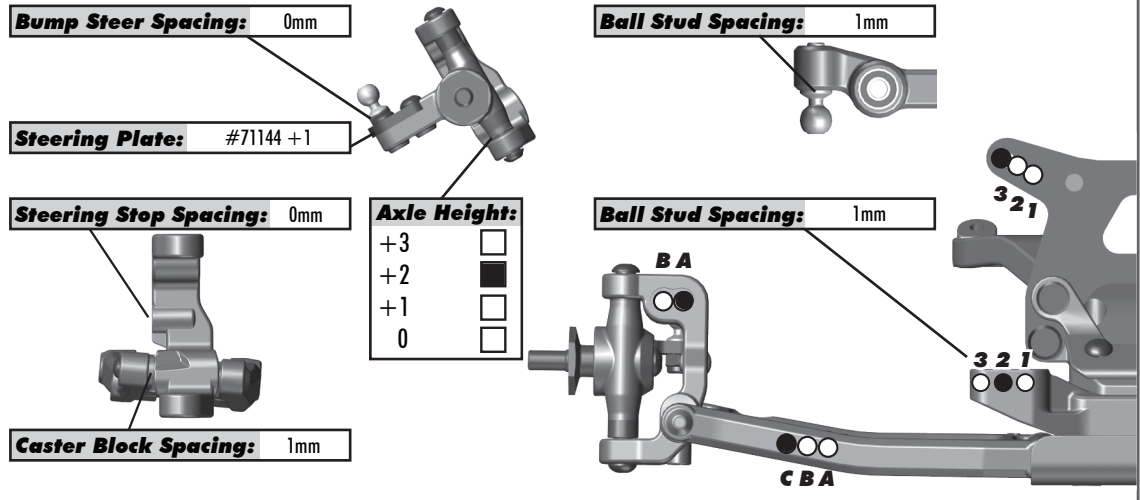

Rear Suspension:

Ride Height:	21mm
Camber:	-1°
Anti-Roll Bar:	
Arm Type:	#91853 73mm
Arm Spacing:	Arm Forward
Hub Spacing:	Towards Hex
Forward	<input type="checkbox"/>
Middle	<input checked="" type="checkbox"/>
Back	<input type="checkbox"/>
Shock Mounting Position:	Front of Arm <input checked="" type="checkbox"/> Rear of Arm <input type="checkbox"/>
Tower Type:	#91881 Wide
Wheel Hex:	5mm
CVA Bone Length:	69mm
CVA Axle:	+2
Notes:	

C Mount: Aluminum Brass

D Mount: Aluminum Brass

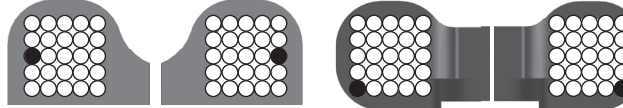

Possible Insert Locations

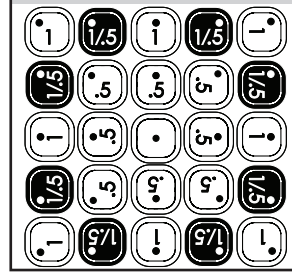

Hub Insert: +3 +2 +1 0

Camber Link Spacing: 1mm

Ball Stud Spacing: 2mm

Ball Stud Spacing: 3mm

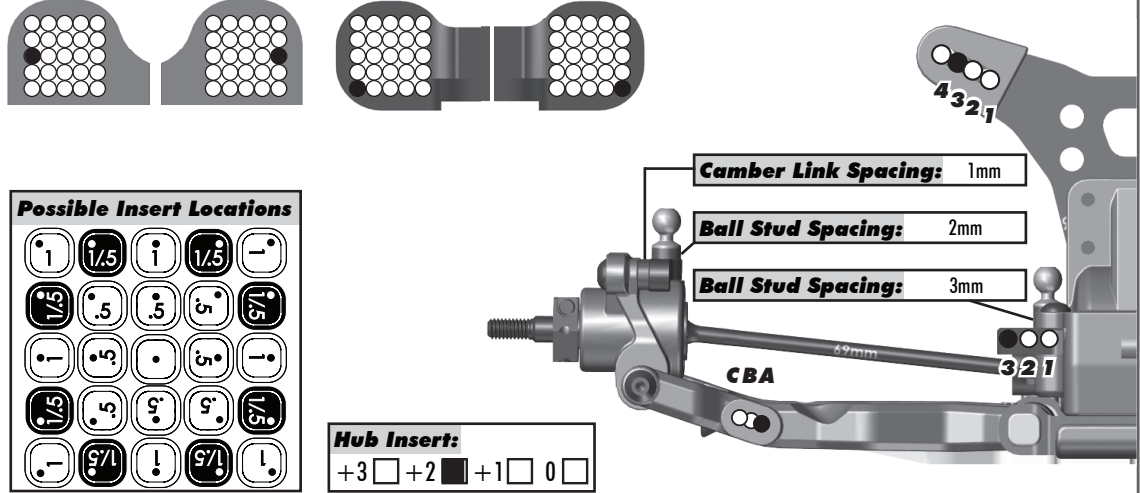

Electronics:

Radio:	Servo:
EPA: Throttle: %	Brake: %
ESC:	
ESC Settings:	
Motor:	
Wind:	Timing:
Pinion:	Spur: 78T
Battery:	
Battery Position:	4F
Battery Weight:	

Drivetrain:

Transmission:	Laydown: <input checked="" type="checkbox"/>
3 Gear:	Layback: <input type="checkbox"/>
4 Gear:	Stand Up: <input type="checkbox"/>
Differential:	Ball Diff: <input checked="" type="checkbox"/>
Height: 2	Gear Diff: <input type="checkbox"/>
Gear Diff Mass:	
Notes:	
Slipper Clutch:	
Type:	HD B6.3
# of Pads:	2 x 11mm ID Ocalock LCF

Shocks:

	Front	Rear
Piston:	2 x 1.6mm (2.0)	2 x 1.7mm (2.0)
Fluid:	35wt	35wt
Spring:	V2 Gray	V2 Gray
Int. Limiters:	0	0
Ext. Limiters:	0	0
Stroke:	21mm	27.5mm
Eyelet Length:	Long (+2)	Long (+2)
Cup Offset:	5mm	5mm
Notes:	2.0mm Pistons	



Track Info:

Size:	Small <input type="checkbox"/>	Medium <input type="checkbox"/>	Large <input type="checkbox"/>	Extra Large <input type="checkbox"/>
Surface:	Dirt <input type="checkbox"/>	Carpet <input type="checkbox"/>	Astroturf <input type="checkbox"/>	Multi Surface <input type="checkbox"/>
Traction:	Low <input type="checkbox"/>	Medium <input type="checkbox"/>	High <input type="checkbox"/>	Very High <input type="checkbox"/>
Moisture:	Dry <input type="checkbox"/>	Damp <input type="checkbox"/>	Wet <input type="checkbox"/>	
Condition:	Indoor <input type="checkbox"/>	Outdoor <input type="checkbox"/>	Dusty <input type="checkbox"/>	Hard Packed <input type="checkbox"/>
	Bumpy <input type="checkbox"/>	Grooved <input type="checkbox"/>	Smooth <input type="checkbox"/>	Loamy <input type="checkbox"/>
Temperature:	Ambient:	Track:		
Notes:				
Vehicle Comments:				

Tires:

Front Tires:	
Front Compound:	
Front Insert:	
Rear Tires:	
Rear Compound:	
Rear Insert:	
Wheel (F/R):	
Notes:	

Chassis, Body, Wing:

Body:	Kit
Front Wing:	Kit
Rear Wing:	Kit
Wing Angle:	0° <input type="checkbox"/> 3° <input type="checkbox"/> 6° <input checked="" type="checkbox"/>
Chassis Length:	#91892
Servo Weights:	
Electronic Weights:	Aluminum
Total Vehicle Weight:	