

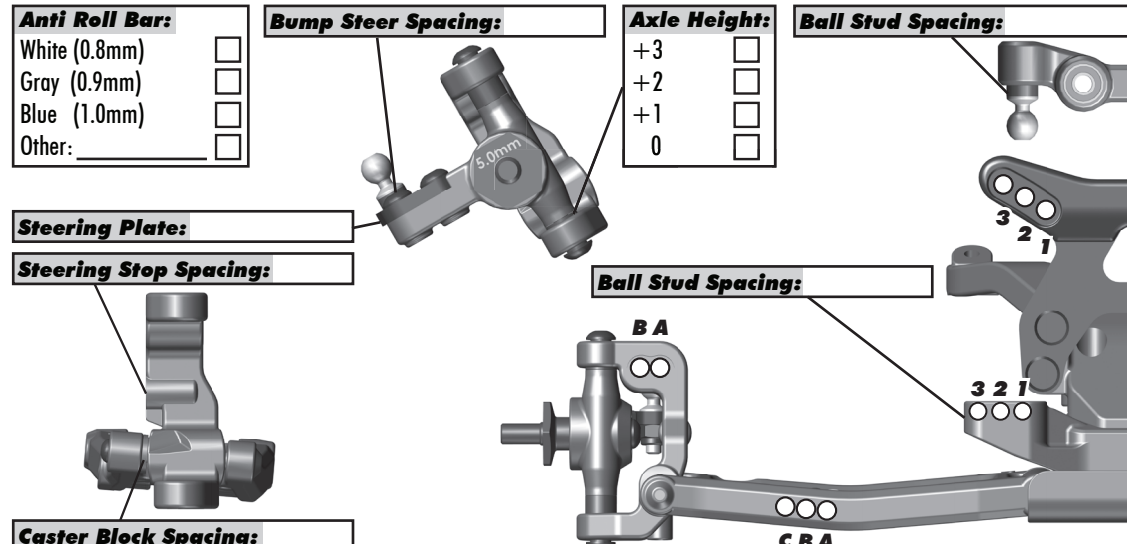
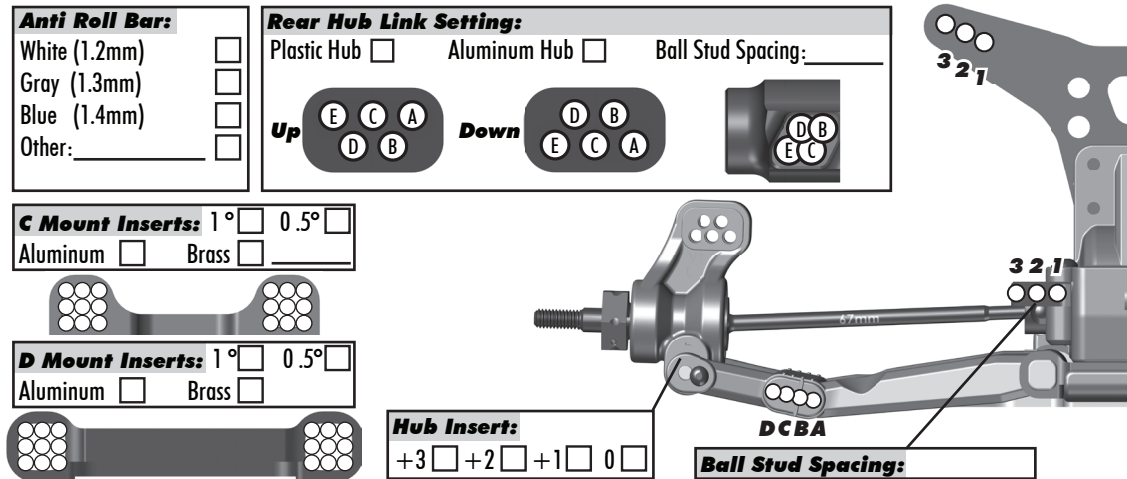

## Front Suspension:

<b>Ride Height:</b>	<b>Anti Roll Bar:</b> White (0.8mm) <input type="checkbox"/> Gray (0.9mm) <input type="checkbox"/> Blue (1.0mm) <input type="checkbox"/> Other: _____ <input type="checkbox"/>	<b>Bump Steer Spacing:</b>	<b>Axle Height:</b> +3 <input type="checkbox"/> +2 <input type="checkbox"/> +1 <input type="checkbox"/> 0 <input type="checkbox"/>	<b>Ball Stud Spacing:</b>
<b>Camber:</b>		<b>Steering Plate:</b>	<b>Ball Stud Spacing:</b>	
<b>Toe:</b>		<b>Steering Stop Spacing:</b>	<b>Ball Stud Spacing:</b>	
<b>Arm Type:</b>		<b>Caster Block Spacing:</b>	<b>Ball Stud Spacing:</b>	
<b>Tower Type:</b>			<b>Ball Stud Spacing:</b>	
<b>Caster Block Insert:</b>				
<b>Steering Block:</b>				
<b>Bulkhead Type:</b>				
<b>Kick-Up Angle:</b>				
<b>Wheel Hex:</b>				
<b>Notes:</b>				

## Rear Suspension:

<b>Ride Height:</b>	<b>Anti Roll Bar:</b> White (1.2mm) <input type="checkbox"/> Gray (1.3mm) <input type="checkbox"/> Blue (1.4mm) <input type="checkbox"/> Other: _____ <input type="checkbox"/>	<b>Rear Hub Link Setting:</b> Plastic Hub <input type="checkbox"/> Aluminum Hub <input type="checkbox"/> Ball Stud Spacing: _____		
<b>Camber:</b>		<b>Up</b>  <b>Down</b> 	<b>Hub Insert:</b> +3 <input type="checkbox"/> +2 <input type="checkbox"/> +1 <input type="checkbox"/> 0 <input type="checkbox"/>	
<b>Tower Type:</b>		<b>C Mount Inserts:</b> 1° <input type="checkbox"/> 0.5° <input type="checkbox"/> Aluminum <input type="checkbox"/> Brass <input type="checkbox"/>	<b>Ball Stud Spacing:</b>	
<b>Wheel Hex:</b>		<b>D Mount Inserts:</b> 1° <input type="checkbox"/> 0.5° <input type="checkbox"/> Aluminum <input type="checkbox"/> Brass <input type="checkbox"/>	<b>Ball Stud Spacing:</b>	
<b>CVA Bone Length:</b>			<b>Ball Stud Spacing:</b>	
<b>CVA Pin Location:</b>				
<b>Hub Spacing:</b> Forward <input type="checkbox"/> Middle <input type="checkbox"/> Back <input type="checkbox"/>				
<b>Shock Mounting Position:</b> Front of Arm <input type="checkbox"/> Rear of Arm <input type="checkbox"/>				
<b>Notes:</b>				

## Electronics:

<b>Radio:</b>	<b>Servo:</b>
<b>EPA:</b> Throttle: _____ % Brake: _____ %	
<b>ESC:</b>	
<b>ESC Settings:</b>	
<b>Motor:</b>	
<b>Wind:</b>	<b>Timing:</b>
<b>Pinion:</b>	<b>Spur:</b>
<b>Battery:</b>	
<b>Battery Position:</b>	

## Drivetrain:

<b>Transmission:</b>	<b>Laydown:</b> <input type="checkbox"/>
<b>3 Gear:</b> <input type="checkbox"/>	<b>Layback:</b> <input type="checkbox"/>
<b>4 Gear:</b> <input type="checkbox"/>	<b>Stand Up:</b> <input type="checkbox"/>
<b>Differential:</b>	<b>Ball Diff:</b> <input type="checkbox"/>
<b>Height:</b> _____	<b>Gear Diff:</b> <input type="checkbox"/>
<b>Notes:</b>	
<b>Slipper Clutch:</b>	
<b>Type:</b>	
<b># of Pads:</b>	

## Shocks:

	Front	Rear
<b>Piston:</b>		
<b>Fluid:</b>		
<b>Spring:</b>		
<b>Limiters:</b>		
<b>Stroke:</b>		
<b>Eyelet Length:</b>		
<b>Cup Offset:</b>		
<b>Notes:</b>		



## Track Info:

<b>Size:</b> Small <input type="checkbox"/> Medium <input type="checkbox"/> Large <input type="checkbox"/> Extra Large <input type="checkbox"/>
<b>Surface:</b> Dirt <input type="checkbox"/> Carpet <input type="checkbox"/> Astroturf <input type="checkbox"/> Multi Surface <input type="checkbox"/>
<b>Traction:</b> Low <input type="checkbox"/> Medium <input type="checkbox"/> High <input type="checkbox"/> Very High <input type="checkbox"/>
<b>Moisture:</b> Dry <input type="checkbox"/> Damp <input type="checkbox"/> Wet <input type="checkbox"/>
<b>Condition:</b> Indoor <input type="checkbox"/> Outdoor <input type="checkbox"/> Dusty <input type="checkbox"/> Hard Packed <input type="checkbox"/> Bumpy <input type="checkbox"/> Grooved <input type="checkbox"/> Smooth <input type="checkbox"/> Loamy <input type="checkbox"/>
<b>Temperature:</b> Ambient: _____ Track: _____
<b>Notes:</b>

## Tires:

<b>Front Tires:</b>
<b>Front Compound:</b>
<b>Front Insert:</b>
<b>Rear Tires:</b>
<b>Rear Compound:</b>
<b>Rear Insert:</b>
<b>Wheel (F/R):</b>
<b>Notes:</b>

## Body, Wing, Weight:

<b>Body:</b>
<b>Wing:</b>
<b>Wing Angle:</b> 0° <input type="checkbox"/> 3° <input type="checkbox"/> 6° <input type="checkbox"/>
<b>Servo Weights:</b> None <input type="checkbox"/> Aluminum <input type="checkbox"/> Steel <input type="checkbox"/> Other <input type="checkbox"/>
<b>Electronic Weights:</b> None <input type="checkbox"/> Aluminum <input type="checkbox"/> Steel <input type="checkbox"/> Other <input type="checkbox"/>
<b>Total Vehicle Weight:</b>

## Vehicle Comments:

**Notes:** \_\_\_\_\_