

Front Suspension

Ride Height: _____
 Camber: _____
 Toe: _____
 Anti-Roll Bar: _____
 Arm Type: _____
 Tower Type: _____
 Caster Block Insert: _____
 Steering Block: _____
 Bulkhead Type: _____
 Kick-Up Angle: _____
 Wheel Hex: _____

Bump Steer Spacing: _____
 Steering Plate: _____
 Steering Stud Spacing: _____
 Axle Height: +3
 +2
 +1
 0
 SCH1256
 Caster Block Spacing: _____

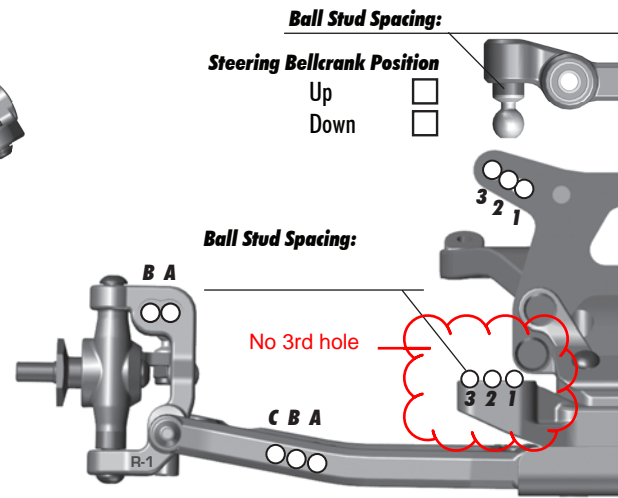

Notes

Rear Suspension

Ride Height: _____
 Camber: _____
 Anti-Roll Bar: _____
 Wheel Hex: _____
 CVA Bone Length: _____
 CVA Axle: _____
 Tower Type: _____
 Arm Type: _____
 Arm Spacing: _____
 Hub Spacing: Forward Middle Back
 Shock Mounting Position: Front of Arm Rear of Arm

C Mount: Aluminum Brass
 D Mount: Aluminum Brass

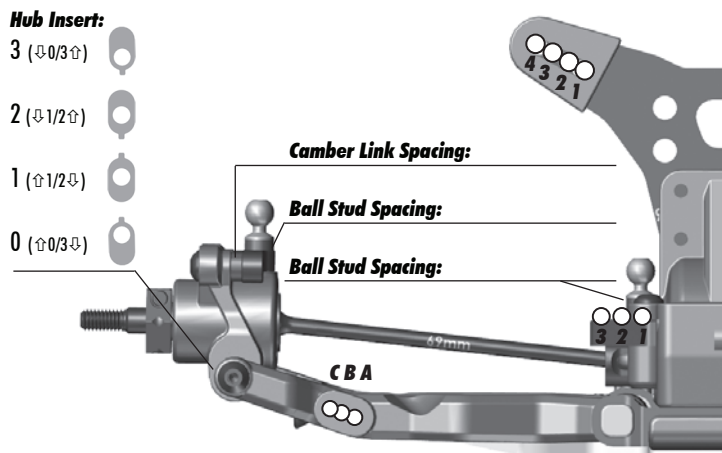

Notes

Electronics, Drivetrain & Shocks

Radio: _____ Servo: _____
 EPA: Throttle: _____ % Brake: _____ %
 ESC: _____
 ESC Settings: _____
 Motor: _____ Timing: _____
 Pinion: _____ Spur: _____
 Battery: _____ Battery Weight: _____
 Battery Position: _____

Transmission
 Laydown Layback
 Differential Height: _____
 Ball Diff Gear Diff:
 Gear Diff. Mass: _____
 Slipper
 Type: _____
 # of Pads: _____
 Setting: _____

Shocks	Front		Rear	
	Int:	Out:	Int:	Out:
Piston:				
Fluid:				
Spring:				
Limiters:				
Stroke:				
Eyelet Length:				
Cup Offset:				
Notes:				



Notes

Track Info, Tires & Aero

Size: Small Medium Large Extra Large
 Surface: Dirt Carpet Astroturf
 Traction: Low Medium High Very High
 Moisture: Dry Damp Wet
 Condition: Indoor Outdoor Dusty Hard Packed
 Bumpy Grooved Smooth Loamy
 Temperature: Ambient: _____ Humidity: _____

Front Tires: _____
 Front Compound: _____
 Front Insert: _____
 Rear Tires: _____
 Rear Compound: _____
 Rear Insert: _____
 Wheel (F/R): _____

Body: _____
 Wing: _____
 Wing Angle: _____
 Front Wing: _____
 Chassis Length: _____
 Servo Weights: _____
 Electronic Weights: _____
 Total Vehicle Weight: _____

Notes

Notes

Comments