

## Front Suspension:

Ride Height: \_\_\_\_\_  
 Camber: \_\_\_\_\_  
 Toe: \_\_\_\_\_  
 Anti-Roll Bar: \_\_\_\_\_  
 Arm Type: \_\_\_\_\_  
 Tower Type: \_\_\_\_\_  
 Wheel Hex: \_\_\_\_\_  
 Steering Block: \_\_\_\_\_  
 Caster Block Insert: \_\_\_\_\_  
 Bulkhead Type: \_\_\_\_\_  
 Kick-Up Angle: \_\_\_\_\_  
 Notes: \_\_\_\_\_

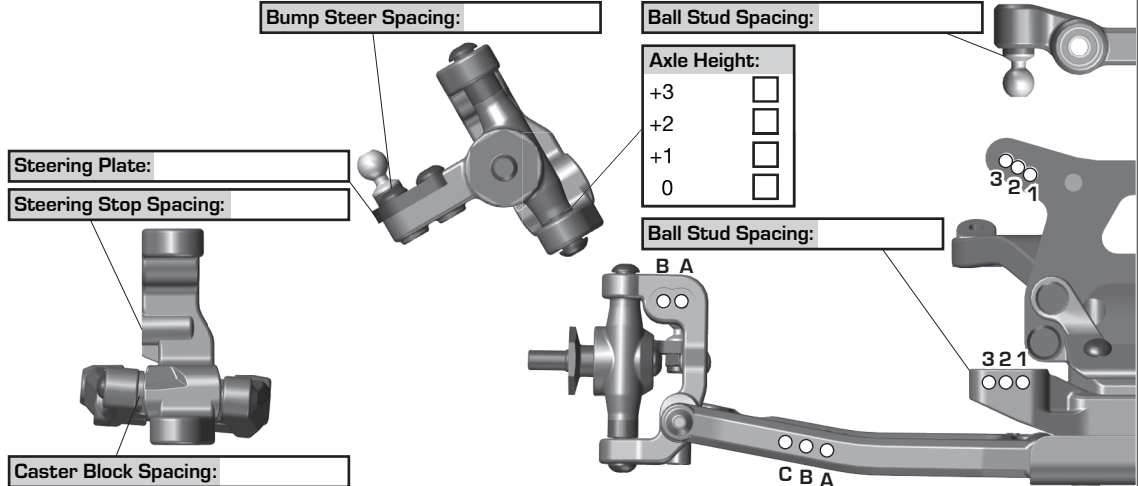

## Rear Suspension:

Ride Height: \_\_\_\_\_  
 Camber: \_\_\_\_\_  
 Anti-Roll Bar: \_\_\_\_\_  
 Arm Type: \_\_\_\_\_  
 Tower Type: \_\_\_\_\_  
 Arm Spacing: \_\_\_\_\_  
 Wheel Hex: \_\_\_\_\_  
 Shock Mounting Position:  
 Front of Arm  Rear of Arm   
 Hub Spacing: Fwd  Mid  Back   
 CVA Bone Length: \_\_\_\_\_  
 CVA Axle Type: \_\_\_\_\_  
 Notes: \_\_\_\_\_

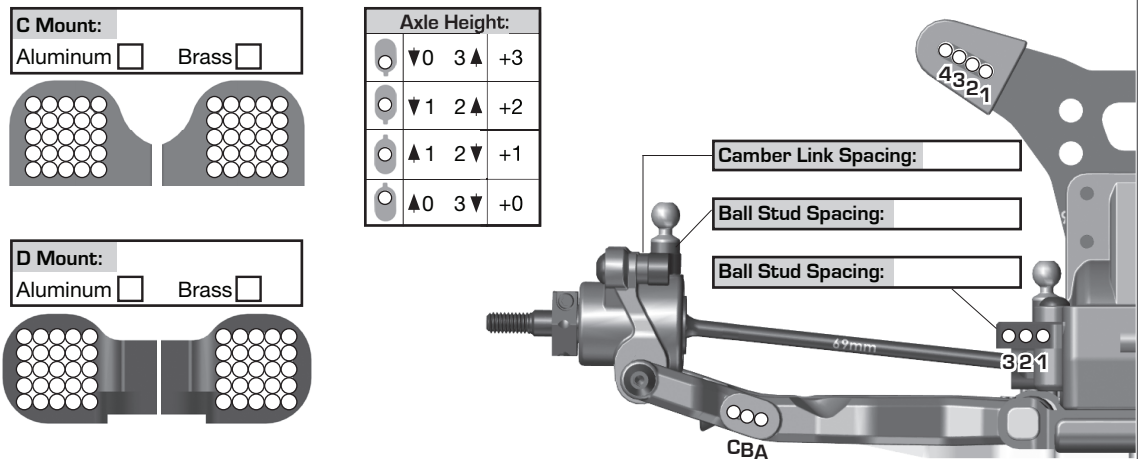

## Electronics:

Radio: \_\_\_\_\_ Servo: \_\_\_\_\_  
 EPA: Throttle: \_\_\_\_\_ % Brake: \_\_\_\_\_ %  
 ESC: \_\_\_\_\_  
 ESC Settings: \_\_\_\_\_  
 Motor: \_\_\_\_\_  
 Wind: \_\_\_\_\_ Timing: \_\_\_\_\_  
 Pinion: \_\_\_\_\_ Spur: \_\_\_\_\_  
 Battery: \_\_\_\_\_  
 Battery Position: \_\_\_\_\_  
 Battery Weight: \_\_\_\_\_

## Drivetrain:

Transmission: \_\_\_\_\_  
 Laydown:  Layback:   
 Differential: \_\_\_\_\_ Ball Diff:   
 Height: \_\_\_\_\_ Gear Diff:   
 Gear Diff Mass: \_\_\_\_\_  
 Notes: \_\_\_\_\_  
**Slipper Clutch:**  
 Type: \_\_\_\_\_  
 # of Pads: \_\_\_\_\_  
 Setting: \_\_\_\_\_

## Shocks:

	Front	Rear
Piston:	_____	_____
Fluid:	_____	_____
Spring:	_____	_____
Limiters:	Int: _____ Ext: _____	Int: _____ Ext: _____
Stroke:	_____	_____
Eyelet Length:	_____	_____
Cup Offset:	_____	_____
Notes:	_____	

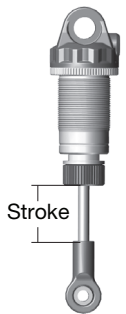

## Track Info:

Size: Small  Medium  Large  Extra Large   
 Surface: Dirt  Carpet  Astroturf  Multi Surface   
 Traction: Low  Medium  High  Very High   
 Moisture: Dry  Damp  Wet   
 Condition: Indoor  Outdoor  Dusty  Hard Packed   
 Bumpy  Grooved  Smooth  Loamy   
 Temperature: Ambient: \_\_\_\_\_ Track: \_\_\_\_\_  
 Notes: \_\_\_\_\_  
 Vehicle Comments: \_\_\_\_\_

## Tires:

Front Tires: \_\_\_\_\_  
 Front Compound: \_\_\_\_\_  
 Front Insert: \_\_\_\_\_  
 Rear Tires: \_\_\_\_\_  
 Rear Compound: \_\_\_\_\_  
 Rear Insert: \_\_\_\_\_  
 Wheel (F/R): \_\_\_\_\_  
 Notes: \_\_\_\_\_

## Body, Weight:

Body: \_\_\_\_\_  
 Front Wing: \_\_\_\_\_  
 Rear Wing: \_\_\_\_\_  
 Wing Angle: \_\_\_\_\_  
 Chassis Length: \_\_\_\_\_  
 Servo Weights: \_\_\_\_\_  
 Electronic Weights: \_\_\_\_\_  
 Total Vehicle Weight: \_\_\_\_\_