

Front Suspension

Ride Height: _____
 Camber: _____
 Toe: _____
 Anti-Roll Bar: _____
 Arm Type: _____
 Tower Type: _____
 Caster Block Insert: _____
 Steering Block: _____
 Bulkhead Type: _____
 Kick-Up Angle: _____
 Wheel Hex: _____

Bump Steer Spacing: _____
 Steering Plate: _____
 Steering Stop Spacing: _____
 Axle Height: +3
 +2
 +1
 0
 SCH1256
 Caster Block Spacing: _____

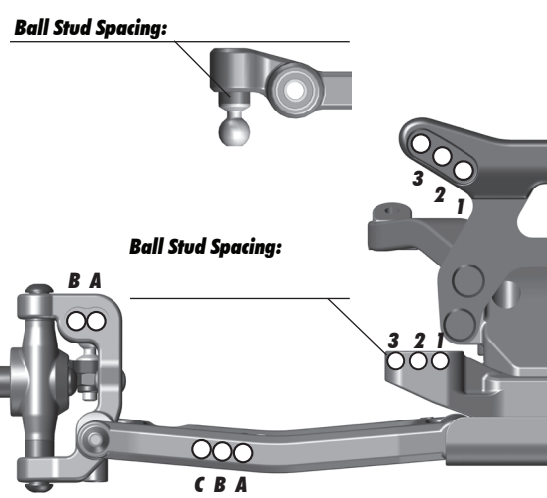

Notes

Rear Suspension

Ride Height: _____
 Camber: _____
 Tower Type: _____
 Wheel Hex: _____
 CVA Bone Length: _____
 CVA Pin Location: _____
 Anti-Roll Bar: _____
 Arm & Position: 73 75 Forward Back
 Hub Spacing: Forward Middle Back
 Shock Mounting Position: Front of Arm Rear of Arm

C Mount Inserts: 1° 0.5°
 Aluminum Brass
 D Mount Inserts: 1° 0.5°
 Aluminum Brass

Hub Insert: 3 (∅-0/3∅)
 2 (∅-1/2∅)
 1 (∅-1/2∅)
 0 (∅-0/3∅)

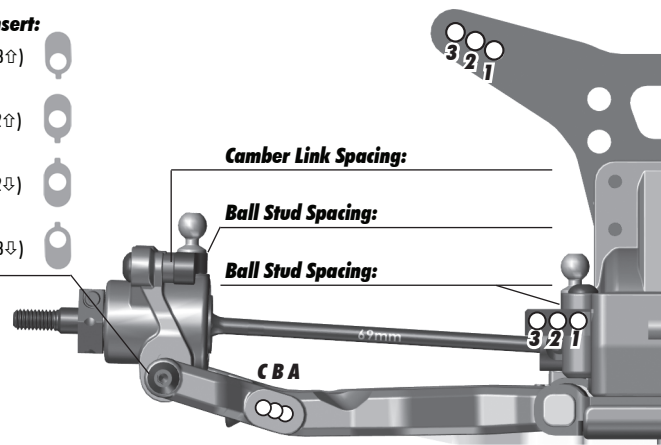

Notes

Track Info, Tires & Aero

Radio: _____ Servo: _____
 EPA: Throttle: _____ % Brake: _____ %
 ESC: _____
 ESC Settings: _____
 Motor: _____ Timing: _____
 Pinion: _____ Spur: _____
 Battery: _____ Battery Weight: _____
 Battery Position: _____

Transmission Laydown Layback Stand-Up
 3 Gear 4 Gear
 Differential Height: _____
 Ball Diff: _____
 Gear Diff: _____
 Slipper Type: _____
 # of Pads: _____

Shocks	Front	Rear
Piston:		
Fluid:		
Spring:		
Int. Limiter:		
Ext. Limiter:		
Stroke:		
Eyelet Length:		
Cup Offset:		
Notes:		

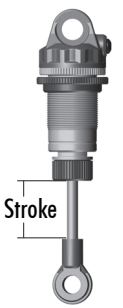

Size: Small Medium Large Extra Large
 Surface: Dirt Carpet Astroturf Multi Surface
 Traction: Low Medium High Very High
 Moisture: Dry Damp Wet
 Condition: Indoor Outdoor Dusty Hard Packed
 Bumpy Grooved Smooth Loamy
 Temperature: Ambient: _____ Humidity: _____

Front Tires: _____
 Front Compound: _____
 Front Insert: _____
 Rear Tires: _____
 Rear Compound: _____
 Rear Insert: _____
 Wheel (F/R): _____

Body: _____
 Wing: _____
 Wing Angle: 0° 3° 6°
 Front Wing: _____
 Chassis Length: _____
 Servo Weights: _____
 Electronic Weights: _____
 Total Vehicle Weight: _____

Notes

Notes

Comments