

Front Suspension

Ride Height: 17mm
 Camber: -1
 Toe: _____
 Arm Type: Gullwing Hard
 Tower Type: Gullwing
 Caster Block Insert: 5*
 Bulkhead Type: Brass
 Kick-Up Angle: 25*
 Wheel Hex: 5.0mm

Anti Roll Bar:
 None
 White (0.8mm)
 Gray (0.9mm)
 Blue (1.0mm)
 Other: _____

Bump Steer Spacing: 0mm

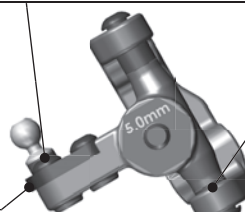

Axle Height:
 +3
 +2
 +1
 0
 SCH1256

Ball Stud Spacing: 2mm

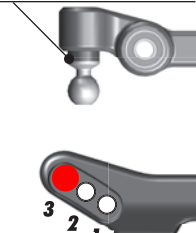

Aluminium steering rack and bell cranks. Proline Front wing.

Steering Plate: Kit

Steering Stop Spacing: 0

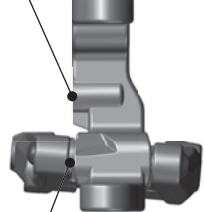

Caster Block Spacing: 1mm

Ball Stud Spacing: 2mm

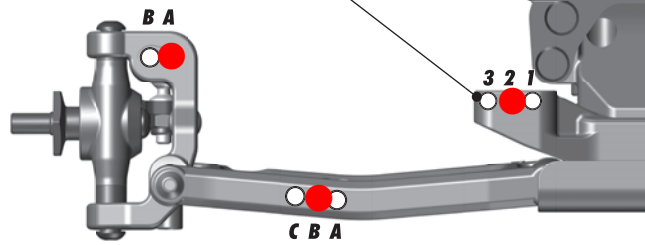

Rear Suspension

Ride Height: 18mm
 Camber: -1
 Wheel Hex: 7.0mm
 Hub Spacing:
 Forward Middle Back
 Shock Mounting Position:
 Front of Arm Rear of Arm

Anti Roll Bar:
 None
 White (1.2mm)
 Gray (1.3mm)
 Blue (1.4mm)
 Other: _____

C Mount Inserts: 1° 0.5°
 Aluminum Brass

D Mount Inserts: 1° 0.5°
 Aluminum Brass

Rear Hub Link Setting:

Plastic Hub Aluminum Hub
 Up  Down 

Spacing:  Ball Stud Spacing

Hub Insert:
 0 (0/3↑)
 +1 (1/2↑)
 +2 (1/2↓)
 +3 (0/3↓)

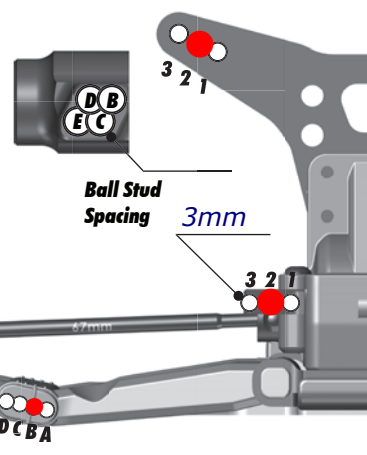

Soft Arms, Tall tower, long shock bodies. 67mm driveshafts.

Track Info, Tires & Aero Electronics, Drivetrain & Shocks

Radio: Ko Propo Servo: Ko propo
 EPA: Throttle: _____ % Brake: _____ %
 ESC: LRP Flow X
 ESC Settings:
 Motor: Reedy 6.5 Timing: 35*
 Pinion: 23 Spur: 81
 Battery: Reedy 4000mah #27325
 Battery Position: Forward

Drivetrain: Height: 2mm
 Transmission:
 3 Gear 4 Gear
 Stand Up Layback
 Ball Diff:
 Gear Diff: 4 x 6k
 Slipper Clutch: Kit
 # of Pads: 2 x LCF

Shocks:	Front	Rear
Piston:	TMG 1.6	TMG 1.7
Fluid:	37.wt	27.5wt
Spring:	V2 Red	V2 White
Limiters:	0	0
Stroke:	21mm	27.5mm
Eyelet Length:	Long	Long
Cup Offset:	+5	+5
Notes:		

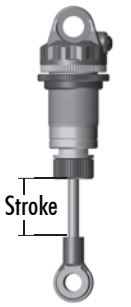

Size: Small Medium Large Extra Large
 Surface: Dirt Carpet Astroturf Multi Surface
 Traction: Low Medium High Very High
 Moisture: Dry Damp Wet
 Condition: Indoor Outdoor Dusty Hard Packed
 Bumpy Grooved Smooth Loamy
 Temperature: Ambient: _____ Humidity: _____
 Notes: _____

Front Tires: Cut stagger
 Front Compound: Yellow
 Front Insert: None
 Rear Tires: Mini Darts
 Rear Compound: Yellow
 Rear Insert: KWF
 Wheel (F/R): Kit
 Notes: _____

Body: Proline Elite lightweight
 Wing: Kit
 Wing Angle: 0° 3° 6°
 Servo Weights: _____
 None Aluminum Steel Other
 Electronic Weights: _____
 None Aluminum Steel Other
 Total Vehicle Weight: _____

Comments