

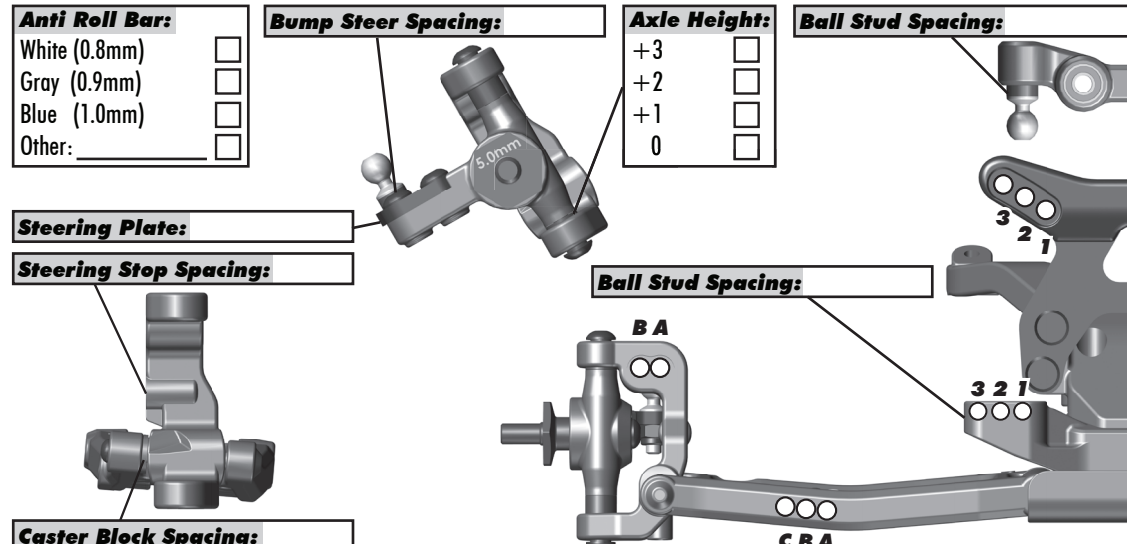
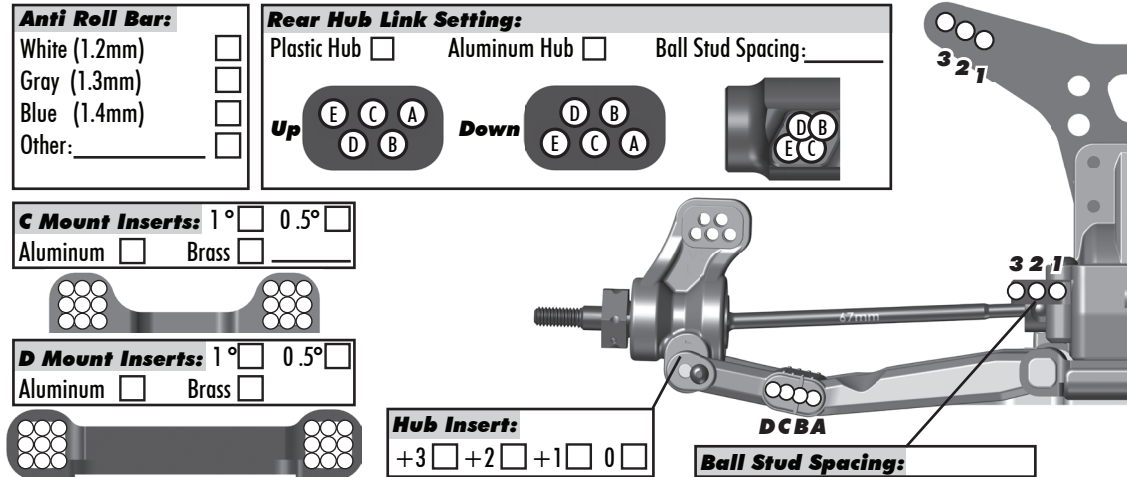

Front Suspension:

Ride Height:	Anti Roll Bar: White (0.8mm) <input type="checkbox"/> Gray (0.9mm) <input type="checkbox"/> Blue (1.0mm) <input type="checkbox"/> Other: _____ <input type="checkbox"/>	Bump Steer Spacing:	Axle Height: +3 <input type="checkbox"/> +2 <input type="checkbox"/> +1 <input type="checkbox"/> 0 <input type="checkbox"/>	Ball Stud Spacing:
Camber:		Steering Plate:	Ball Stud Spacing:	
Toe:		Steering Stop Spacing:	Ball Stud Spacing:	
Arm Type:		Caster Block Spacing:	Ball Stud Spacing:	
Tower Type:			Ball Stud Spacing:	
Caster Block Insert:				
Steering Block:				
Bulkhead Type:				
Kick-Up Angle:				
Wheel Hex:				
Notes:				

Rear Suspension:

Ride Height:	Anti Roll Bar: White (1.2mm) <input type="checkbox"/> Gray (1.3mm) <input type="checkbox"/> Blue (1.4mm) <input type="checkbox"/> Other: _____ <input type="checkbox"/>	Rear Hub Link Setting: Plastic Hub <input type="checkbox"/> Aluminum Hub <input type="checkbox"/> Ball Stud Spacing: _____		
Camber:		Up  Down 	Hub Insert: +3 <input type="checkbox"/> +2 <input type="checkbox"/> +1 <input type="checkbox"/> 0 <input type="checkbox"/>	
Tower Type:		C Mount Inserts: 1° <input type="checkbox"/> 0.5° <input type="checkbox"/> Aluminum <input type="checkbox"/> Brass <input type="checkbox"/>	Ball Stud Spacing:	
Wheel Hex:		D Mount Inserts: 1° <input type="checkbox"/> 0.5° <input type="checkbox"/> Aluminum <input type="checkbox"/> Brass <input type="checkbox"/>	Ball Stud Spacing:	
CVA Bone Length:			Ball Stud Spacing:	
CVA Pin Location:				
Hub Spacing: Forward <input type="checkbox"/> Middle <input type="checkbox"/> Back <input type="checkbox"/>				
Shock Mounting Position: Front of Arm <input type="checkbox"/> Rear of Arm <input type="checkbox"/>				
Notes:				

Electronics:

Radio:	Servo:
EPA: Throttle: _____ % Brake: _____ %	
ESC:	
ESC Settings:	
Motor:	
Wind:	Timing:
Pinion:	Spur:
Battery:	
Battery Position:	

Drivetrains:

Transmission:	Laydown: <input type="checkbox"/>
3 Gear: <input type="checkbox"/>	Layback: <input type="checkbox"/>
4 Gear: <input type="checkbox"/>	Stand Up: <input type="checkbox"/>
Differential:	Ball Diff: <input type="checkbox"/>
Height: _____	Gear Diff: <input type="checkbox"/>
Notes:	
Slipper Clutch:	
Type:	
# of Pads:	

Shocks:

	Front	Rear
Piston:		
Fluid:		
Spring:		
Limiters:		
Stroke:		
Eyelet Length:		
Cup Offset:		
Notes:		



Track Info:

Size: Small <input type="checkbox"/> Medium <input type="checkbox"/> Large <input type="checkbox"/> Extra Large <input type="checkbox"/>
Surface: Dirt <input type="checkbox"/> Carpet <input type="checkbox"/> Astroturf <input type="checkbox"/> Multi Surface <input type="checkbox"/>
Traction: Low <input type="checkbox"/> Medium <input type="checkbox"/> High <input type="checkbox"/> Very High <input type="checkbox"/>
Moisture: Dry <input type="checkbox"/> Damp <input type="checkbox"/> Wet <input type="checkbox"/>
Condition: Indoor <input type="checkbox"/> Outdoor <input type="checkbox"/> Dusty <input type="checkbox"/> Hard Packed <input type="checkbox"/> Bumpy <input type="checkbox"/> Grooved <input type="checkbox"/> Smooth <input type="checkbox"/> Loamy <input type="checkbox"/>
Temperature: Ambient: _____ Track: _____
Notes:

Tires:

Front Tires:
Front Compound:
Front Insert:
Rear Tires:
Rear Compound:
Rear Insert:
Wheel (F/R):
Notes:

Body, Wing, Weight:

Body:
Wing:
Wing Angle: 0° <input type="checkbox"/> 3° <input type="checkbox"/> 6° <input type="checkbox"/>
Servo Weights: None <input type="checkbox"/> Aluminum <input type="checkbox"/> Steel <input type="checkbox"/> Other <input type="checkbox"/>
Electronic Weights: None <input type="checkbox"/> Aluminum <input type="checkbox"/> Steel <input type="checkbox"/> Other <input type="checkbox"/>
Total Vehicle Weight:

Vehicle Comments:

Notes: _____