

Front Suspension

**Ride Height:** \_\_\_\_\_  
**Camber:** \_\_\_\_\_  
**Toe:** \_\_\_\_\_  
**Arm Type:** \_\_\_\_\_  
**Tower Type:** \_\_\_\_\_  
**Caster Block Insert:** \_\_\_\_\_  
**Bulkhead Type:** \_\_\_\_\_  
**Kick-Up Angle:** \_\_\_\_\_  
**Wheel Hex:** \_\_\_\_\_

**Anti Roll Bar:**  
 None   
 White (0.8mm)   
 Gray (0.9mm)   
 Blue (1.0mm)   
 Other: \_\_\_\_\_

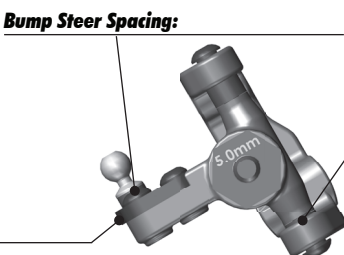

**Axle Height:**  
 +3   
 +2   
 +1   
 0   
 SCH1256

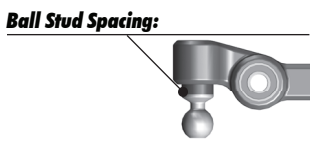

**Steering Plate:** \_\_\_\_\_

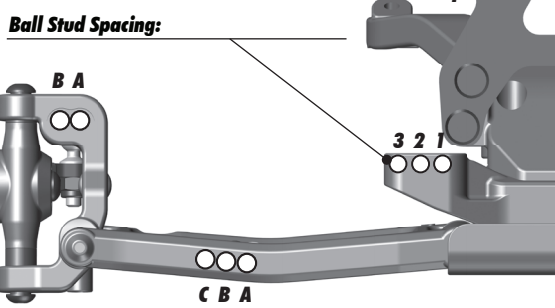
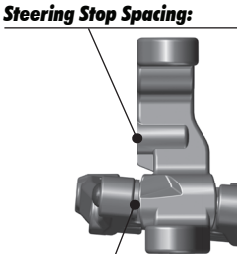

Notes

**Caster Block Spacing:** \_\_\_\_\_

Rear Suspension

**Ride Height:** \_\_\_\_\_  
**Camber:** \_\_\_\_\_  
**Wheel Hex:** \_\_\_\_\_  
**Hub Spacing:**  
 Forward  Middle  Back   
**Shock Mounting Position:**  
 Front of Arm  Rear of Arm

**Anti Roll Bar:**  
 None   
 White (1.2mm)   
 Gray (1.3mm)   
 Blue (1.4mm)   
 Other: \_\_\_\_\_

**C Mount Inserts:** 1°  0.5°   
 Aluminum  Brass

**D Mount Inserts:** 1°  0.5°   
 Aluminum  Brass

**Rear Hub Link Setting:**  
 Plastic Hub  Aluminum Hub   
 Up Down

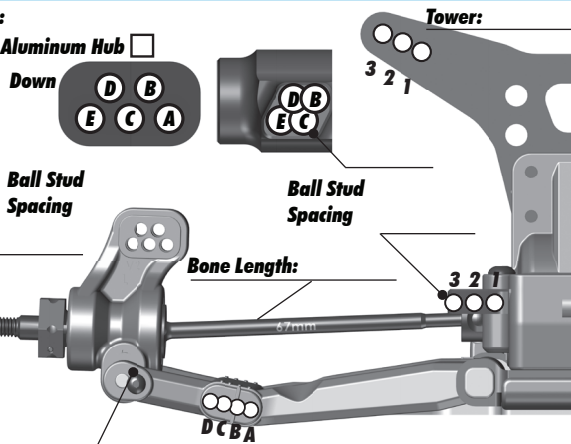

Notes

Track Info, Tires & Aero

**Radio:** \_\_\_\_\_ **Servo:** \_\_\_\_\_  
**EPA:** Throttle: \_\_\_\_\_ % Brake: \_\_\_\_\_ %  
**ESC:** \_\_\_\_\_  
**ESC Settings:** \_\_\_\_\_  
**Motor:** \_\_\_\_\_ **Timing:** \_\_\_\_\_  
**Pinion:** \_\_\_\_\_ **Spur:** \_\_\_\_\_  
**Battery:** \_\_\_\_\_  
**Battery Position:** \_\_\_\_\_

**Drivetrain:** \_\_\_\_\_ **Height:** \_\_\_\_\_  
**Transmission:**  
 3 Gear  4 Gear  
 Stand Up  Layback  
 Ball Diff:  
 Gear Diff:  
**Slipper Clutch:** \_\_\_\_\_  
**# of Pads:** \_\_\_\_\_

Shocks:	Front	Rear
<b>Piston:</b>		
<b>Fluid:</b>		
<b>Spring:</b>		
<b>Limiters:</b>		
<b>Stroke:</b>		
<b>Eyelet Length:</b>		
<b>Cup Offset:</b>		
<b>Notes:</b>		

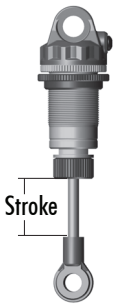

**Size:** Small  Medium  Large  Extra Large   
**Surface:** Dirt  Carpet  Astroturf  Multi Surface   
**Traction:** Low  Medium  High  Very High   
**Moisture:** Dry  Damp  Wet   
**Condition:** Indoor  Outdoor  Dusty  Hard Packed   
 Bumpy  Grooved  Smooth  Loamy   
**Temperature:** Ambient: \_\_\_\_\_ Humidity: \_\_\_\_\_  
**Notes:** \_\_\_\_\_

**Front Tires:** \_\_\_\_\_  
**Front Compound:** \_\_\_\_\_  
**Front Insert:** \_\_\_\_\_  
**Rear Tires:** \_\_\_\_\_  
**Rear Compound:** \_\_\_\_\_  
**Rear Insert:** \_\_\_\_\_  
**Wheel (F/R):** \_\_\_\_\_  
**Notes:** \_\_\_\_\_

**Body:** \_\_\_\_\_  
**Wing:** \_\_\_\_\_  
**Wing Angle:** 0°  3°  6°   
**Servo Weights:** \_\_\_\_\_  
 None  Aluminum  Steel  Other   
**Electronic Weights:** \_\_\_\_\_  
 None  Aluminum  Steel  Other   
**Total Vehicle Weight:** \_\_\_\_\_

Comments

\_\_\_\_\_