

**Front Suspension:**

**Camber:** \_\_\_\_\_ °  
**Total Toe:** \_\_\_\_\_ °  
**Ride Height:** \_\_\_\_\_  
**Arm Type:** \_\_\_\_\_  
**Tower Type:** \_\_\_\_\_  
**Caster Block Insert:** \_\_\_\_\_ °  
**Kick-Up Angle:** \_\_\_\_\_ °

**Notes:** \_\_\_\_\_  
\_\_\_\_\_  
\_\_\_\_\_

**Bump Steer Spacing:**

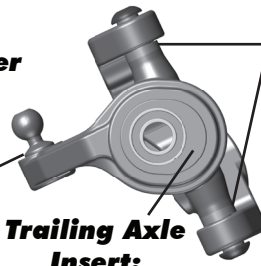

**Trailing Axle Insert:**

2mm  3mm  4mm

**Steering Stop Spacing:**

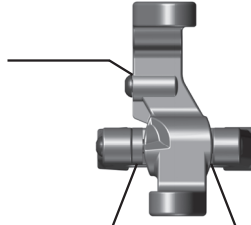

**Caster Block Spacing:**

**Axle Height:**

Up   
Middle   
Down

**Ball Stud Spacing:**



**Ball Stud Spacing:**

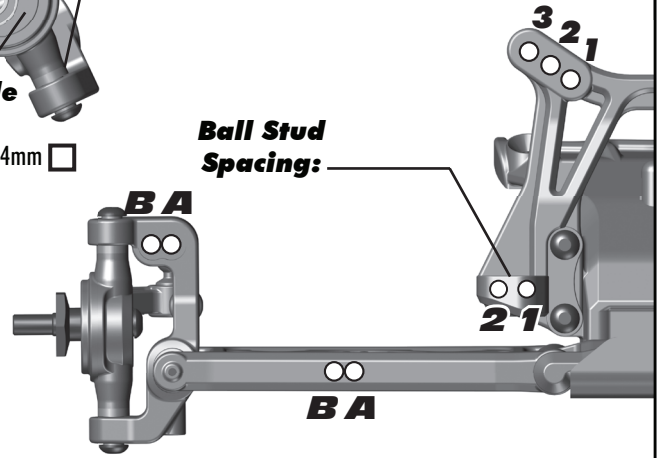

**Rear Suspension:**

**Camber:** \_\_\_\_\_ °  
**Ride Height:** \_\_\_\_\_  
**Hub Spacing:**

Forward  Middle  Back

**Notes:** \_\_\_\_\_  
\_\_\_\_\_  
\_\_\_\_\_

**Anti Roll Bar:**

None   
Black (1.2mm)   
Silver (1.3mm)   
Gold (1.4mm)

**Rear Hub Link Setting:**

**A**  C  B  A  Up   
Down   
**B**  B  A  Up   
Down

**Ball Stud Spacing:**



**Arm Mount:**

**Inboard Toe:** \_\_\_\_\_ °

**Anti-Squat:** \_\_\_\_\_ °

**Hub Insert:**

0°  0.5°  1°

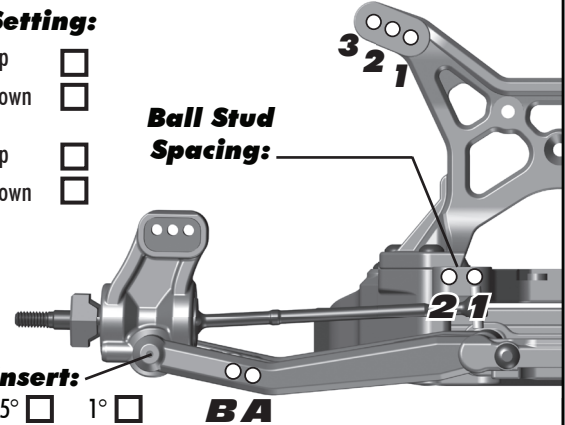

**Electronics:**

**Radio:** \_\_\_\_\_ **Servo:** \_\_\_\_\_  
**EPA: Throttle:** \_\_\_\_\_ % **Brake:** \_\_\_\_\_ %  
**ESC:** \_\_\_\_\_  
**ESC Settings:** \_\_\_\_\_  
**Motor:** \_\_\_\_\_  
**Wind:** \_\_\_\_\_ **Timing:** \_\_\_\_\_  
**Pinion:** \_\_\_\_\_ **Spur:** \_\_\_\_\_  
**Battery:** \_\_\_\_\_  
**Battery Position:** \_\_\_\_\_

**Drivetrain:**

**Differential:**

Ball:   
Setting: \_\_\_\_\_  
Gear:   
Oil: \_\_\_\_\_

**Slipper Clutch:**

**Type:** \_\_\_\_\_  
**# of Pads:** \_\_\_\_\_  
**Notes:** \_\_\_\_\_

**Shocks:**

	Front	Rear
<b>Piston:</b>		
<b>Oil:</b>		
<b>Spring:</b>		
<b>Limiters:</b>		
<b>Cup Offset:</b>		
<b>Stroke:</b>		
<b>Free Length:</b>		
<b>Notes:</b>		

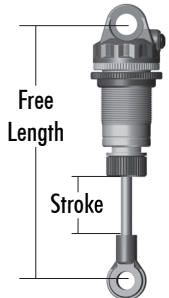

**Track Info:**

**Size:** Small  Medium  Large  Extra Large   
**Surfaces:** Dirt  Carpet  AstroTurf  Multi Surface   
**Traction:** Low  Medium  High  Very High   
**Moisture:** Dry  Damp  Wet   
**Condition:** Indoor  Outdoor  Dusty  Hard Packed   
Bumpy  Grooved  Smooth  Loamy

**Temperature:** Ambient: \_\_\_\_\_ Track: \_\_\_\_\_

**Notes:** \_\_\_\_\_  
\_\_\_\_\_

**Tires:**

**Tires (F/R):** \_\_\_\_\_ / \_\_\_\_\_  
**Compound (F/R):** \_\_\_\_\_ / \_\_\_\_\_  
**Insert (F/R):** \_\_\_\_\_ / \_\_\_\_\_  
**Wheel (F/R):** \_\_\_\_\_ / \_\_\_\_\_  
**Notes:** \_\_\_\_\_

**Body & Wing:**

**Body:** \_\_\_\_\_  
**Wing:** \_\_\_\_\_  
**Wing Angle:** 0°  3°  6°  \_\_\_\_\_  
**Notes:** \_\_\_\_\_

**Race Results:**

**Qualify:** \_\_\_\_\_ **Main:** \_\_\_\_\_  
**Finish:** \_\_\_\_\_ **TQ:**   
**Best Lap Time:** \_\_\_\_\_

**Vehicle Comments:**

\_\_\_\_\_  
\_\_\_\_\_  
**Total Vehicle Weight:** \_\_\_\_\_