

Front Suspension:

Reset Forms

Camber: -1
Total Toe: 0
Ride Height: 24mm
Arm Type: Flat - Plastic
Tower Type: Flat - Hard
Caster Block Insert: 5
Kick-Up Angle: 25

Notes: Hard Front Tower, Hard Steering Blocks, Hard Castor Blocks
FT Aluminum Steering, FT Axles and Hex

Bump Steer Spacing: 0
Trailing Axle Insert: 2mm 3mm 4mm
Ball Stud Spacing: 2mm

Steering Stop Spacing: None 2mm 0

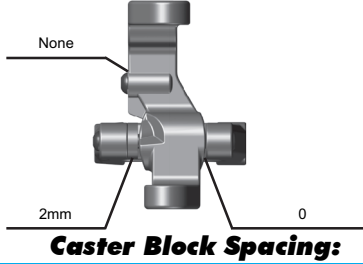

Axle Height: Up Middle Down

Ball Stud Spacing: 1.5mm

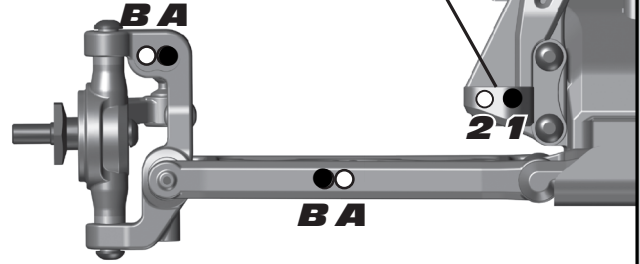

Rear Suspension:

Camber: -1
Ride Height: 24mm
Hub Spacing: Forward Middle Back

Notes: Hard Rear Tower, Hard Rear Ballstud Mount, Hard Hubs
FT Aluminum C + D Arm Mounts, FT Hex

Anti Roll Bar: None Black (1.2mm) Silver (1.3mm) Gold (1.4mm)
Rear Hub Link Setting: A C A Up Down B B A Up Down

Arm Mount: 3
Inboard Toe: 2
Anti-Squat: 0° 0.5° 1°



Hub Insert: BA

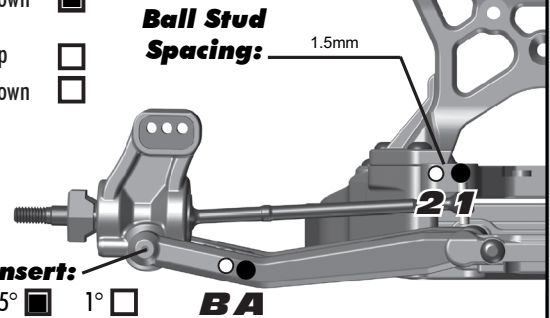

Electronics:

Radio: m12 **Servo:** Airtronics 94671
EPA: Throttle: 97 % **Brake:** 87 %
ESC: LRP Flow
ESC Settings: 5/2/2/2/0/0/0
Motor: Reedy Sonic 2
Wind: 8.5 **Timing:** 10°
Pinion: 23 **Spur:** 78
Battery: Reedy Shorty #738
Battery Position: Rear

Drivetrains:

Differential: Ball: Setting: Medium
Gear: Oil: _____

Slipper Clutch:

Type: Associated Vented
of Pads: 2
Notes: Cut 2mm From Inner Diameter on Inside Pad

Shocks:

	Front	Rear
Piston:	3 x 1.4	3 x 1.4
Oil:	AE 32.5	AE 27.5
Spring:	K - White	K - Gold
Limiters:	2	2
Cup Offset:	Medium	Medium
Stroke:	20.5mm	26.5mm
Free Length:		
Notes:	#91493 Low Friction X-Rings	

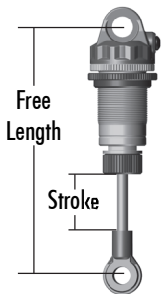

Track Info:

Size: Small Medium Large Extra Large
Surfaces: Dirt Carpet Astroturf Multi Surface
Traction: Low Medium High Very High
Moisture: Dry Damp Wet
Condition: Indoor Outdoor Dusty Hard Packed Bumpy Grooved Smooth Loamy

Temperature: Ambient: 75 **Track:** _____
Notes: Hard Pack with a groove forming and sections with sharp ruts

Tires:

Tires (F/R): AKA Impact / AKA Impact
Compound (F/R): Super Soft / Super Soft
Insert (F/R): Jconcepts And+1 / Jconcepts And+1
Wheel (F/R): AE Hex / AE Hex
Notes: Front Tires Were Cut From 4wd Fronts

Body & Wing:

Body: Kit
Wing: Jconcepts
Wing Angle: 0° 3° 6°
Notes: Wing cut to 1 line

Race Results:

Qualify: 1 **Main:** A
Finish: 1 **TQ:**
Best Lap Time: 27.957

Vehicle Comments:

Lunsford Titanium Screw Kit, Schelle Bearings

Total Vehicle Weight: _____