

## Front Suspension:

**Camber:** \_\_\_\_\_  
**Total Toe:** \_\_\_\_\_  
**Ride Height:** \_\_\_\_\_  
**Arm Type:** \_\_\_\_\_  
**Tower Type:** \_\_\_\_\_  
**Caster Block Insert:** \_\_\_\_\_  
**Kick-Up Angle:** \_\_\_\_\_  
**Wheel Hex:** \_\_\_\_\_  
**Notes:** \_\_\_\_\_

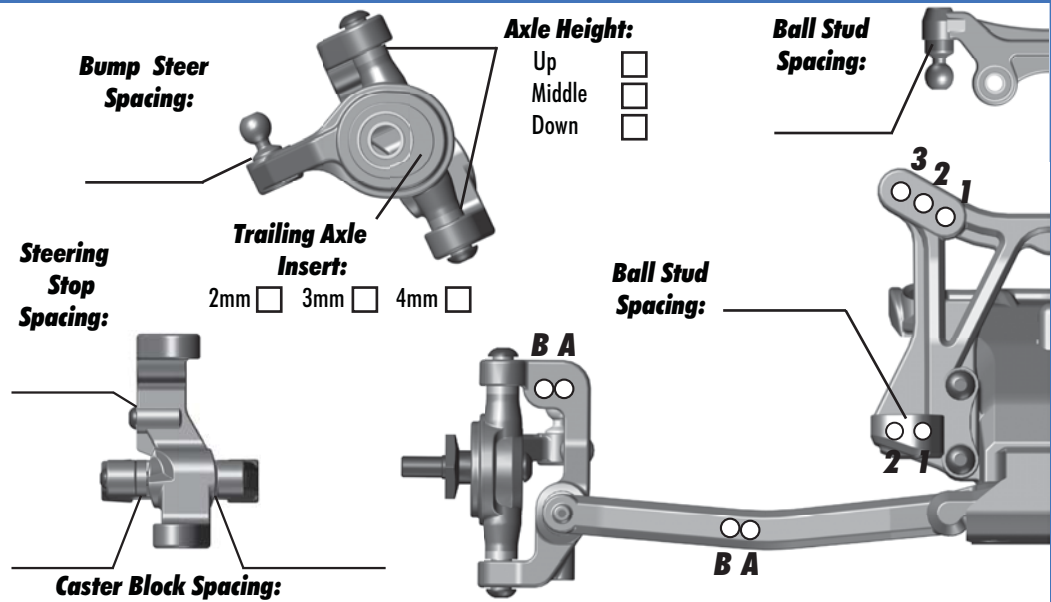

## Rear Suspension:

**Camber:** \_\_\_\_\_  
**Ride Height:** \_\_\_\_\_  
**Wheel Hex:** \_\_\_\_\_  
**Hub Spacing:** Forward  Middle  Back   
**Notes:** \_\_\_\_\_

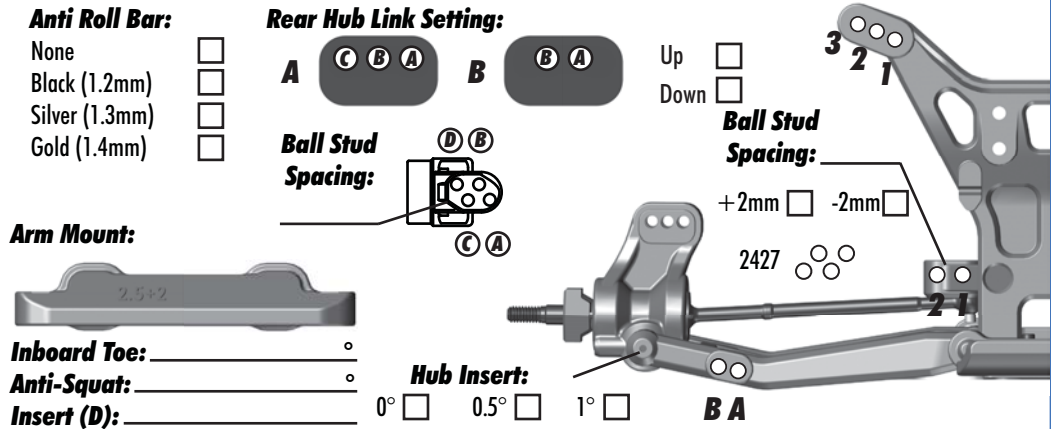

## Electronics:

**Radio:** \_\_\_\_\_ **Servo:** \_\_\_\_\_  
**EPA: Throttle:** \_\_\_\_\_ % **Brake:** \_\_\_\_\_ %  
**ESC:** \_\_\_\_\_  
**ESC Settings:** \_\_\_\_\_  
**Motor:** \_\_\_\_\_  
**Wind:** \_\_\_\_\_ **Timing:** \_\_\_\_\_  
**Pinion:** \_\_\_\_\_ **Spur:** \_\_\_\_\_  
**Battery:** \_\_\_\_\_  
**Battery Position:** \_\_\_\_\_

## Drivetrain:

**Differential:** Ball  Gear   
**Gearbox:** 3 Gears  4 Gears   
**Notes:** \_\_\_\_\_  
**Slipper Clutch:** \_\_\_\_\_  
**Type:** \_\_\_\_\_  
**# of Pads:** \_\_\_\_\_  
**Notes:** \_\_\_\_\_

## Shocks:

	Front	Rear
<b>Piston:</b>		
<b>Oil:</b>		
<b>Spring:</b>		
<b>Limiters:</b>		
<b>Cup Offset:</b>		
<b>Stroke:</b>		
<b>Free Length:</b>		
<b>Notes:</b>		

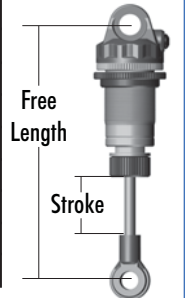

## Track Info:

**Size:** Small  Medium  Large  Extra Large   
**Surfaces:** Dirt  Carpet  Astroturf  Multi Surface   
**Traction:** Low  Medium  High  Very High   
**Moisture:** Dry  Damp  Wet   
**Condition:** Indoor  Outdoor  Dusty  Hard Packed   
 Bumpy  Grooved  Smooth  Loamy   
**Temperature:** Ambient: \_\_\_\_\_ Track: \_\_\_\_\_  
**Notes:** \_\_\_\_\_

## Tires:

\_\_\_\_\_ :F - Tires - R:  
 \_\_\_\_\_ :F - Compound - R:  
 \_\_\_\_\_ :F - Insert - R:  
 \_\_\_\_\_ :F - Wheel - R:  
 \_\_\_\_\_ :F - Notes - R:

## Body & Wing:

**Body:** \_\_\_\_\_  
**Wing:** \_\_\_\_\_  
**Wing Angle:** 0°  3°  6°   
**Notes:** \_\_\_\_\_

## Race Results:

**Quality:** \_\_\_\_\_ **Main:** \_\_\_\_\_  
**Finish:** \_\_\_\_\_ **TQ:**   
**Best Lap Time:** \_\_\_\_\_  
**Team Associated**

## Vehicle Comments:

**Total Vehicle Weight:** \_\_\_\_\_