

Front Suspensions:

Camber: -1.5 °
Total Toe: 0 °
Ride Height: 24 mm
Arm Type: #91398 Flat, Standard
Tower Type: #91374 Flat, Hard
Caster Block Insert: 5 °
Kick-Up Angle: 25 °

Notes: #91363 Factory Team Top Plate, Hard
#91401 Factory Team Caster Block, Hard
#91373 Plastic Front Hinge Pin Brace
#91392 Factory Team Aluminum Steering Set
#91403 Factory Team Caster Block Bushings, Offset

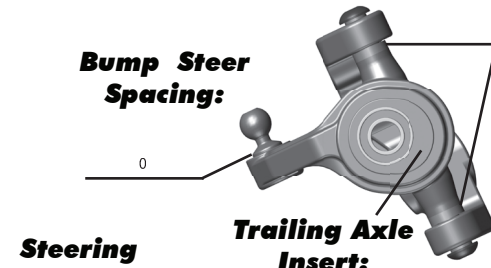

Axle Height:
Up
Middle
Down

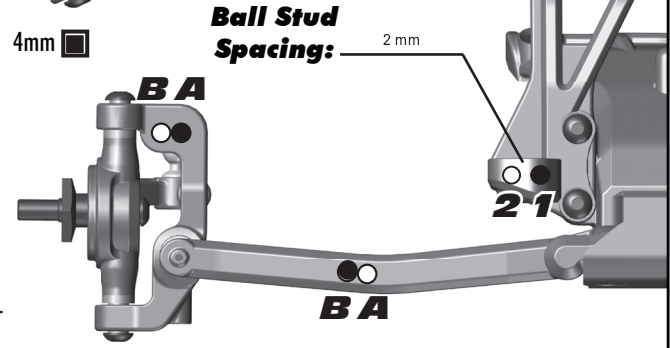
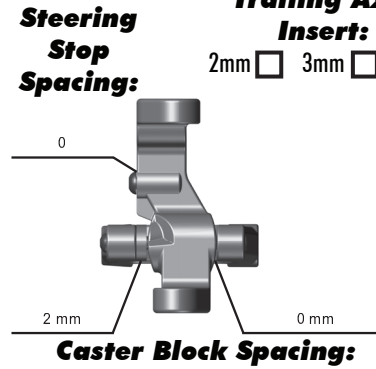

Rear Suspension:

Camber: -1.5 °
Ride Height: 24 mm
Hub Spacing: Forward Middle Back

Notes: #91413 Factory Team Rear Arms, Hard
#91548 Factory Team 0° Aluminum Hubs (Back Row Inside + 3 mm)
#91520 Factory Team Aluminum Camber Link Mount (Low + 3 mm)
#91522 & 91524 Factory Team Aluminum "C" and "D" plate

Anti Roll Bar: None
Black (1.2mm)
Silver (1.3mm)
Gold (1.4mm)

Rear Hub Link Setting:
A C A Up
Down
B B A Up
Down



Arm Mount: 3 °
Inboard Toe: 2 °
Anti-Squat: 0° 0.5° 1°

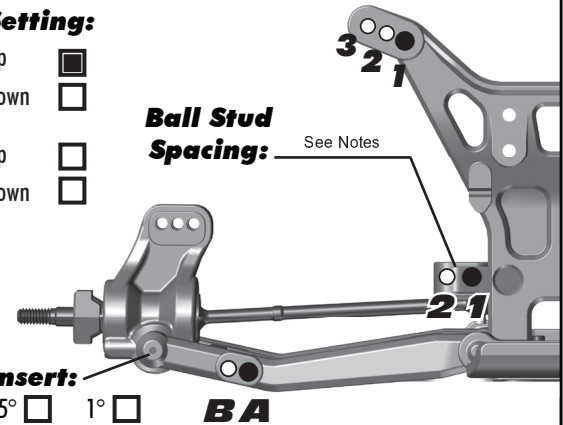

Electronics:

Radio: Airtronics M12 **Servo:** XP 1313
EPA Throttle: 100 % **Brake:** 80 %
ESC: Reedy BlackBox
ESC Settings: N/A
Motor: Reedy Sonic Mach2
Wind: 7.5 **Timing:** 20
Pinion: 23 **Spur:** 81
Battery: Reedy #602 Shorty
Battery Position: Back

Drivetrain:

Differential:
Ball:
Setting: Standard
Gear:
Oil:

Slipper Clutch:

Type: AVID
of Pads: 3
Notes: All white pads

Shocks:

	Front	Rear
Piston:	3 x 1.4 Tapered	3 x 1.4 Flat
Oil:	35	30
Spring:	White	White
Limiters:	1	1
Cup Offset:	5 mm	5 mm
Stroke:	20.5 mm	26.5 mm
Free Length:	N/A	N/A
Notes:	#91493 Factory Team Low Friction X-Rings	

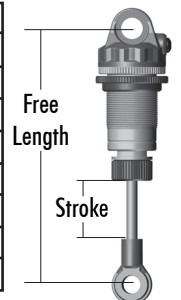

Track Info:

Size: Small Medium Large Extra Large
Surfaces: Dirt Carpet Astroturf Multi Surface
Traction: Low Medium High Very High
Moisture: Dry Damp Wet
Condition: Indoor Outdoor Dusty Hard Packed
Bumpy Grooved Smooth Loamy

Temperature: Ambient: 75 Track: 70
Notes: Minimum groove with dust outside; Dries out during the day

Tires:

Tires (F/R): JConcepts Dirt Webs / JConcepts Dirt Webs
Compound (F/R): Gold / Gold
Insert (F/R): JConcepts Dirt Tech / JConcepts Dirt Tech
Wheel (F/R): JConcepts Mono / JConcepts Mono
Notes:

Body & Wing:

Body: JConcepts Silencer
Wing: JConcepts High Clearance 6.5"
Wing Angle: 0° 3° 6°
Notes: Wing lip cut to two lines

Race Results:

Qualify: 1 **Main:** A
Finish: **TQ:**
Best Lap Time: 21.1

Vehicle Comments:

#91551 Factory Team Bearing Set; #91545 Factory Team Graphite Battery Strap; #91446 & 91447 Factory Team Shock Bushings; #91547 Factory Team Milled Motor Plate; Lunsford screw kit & front axles;

Total Vehicle Weight: 1621g