

**Front Suspensions:**

Reset Forms

**Camber:** -1

**Total Toe:** -1/4

**Ride Height:** 24 mm

**Arm Type:** #91399 Flat, Hard

**Tower Type:** #91373 Flat, Standard

**Caster Block Insert:** 5

**Kick-Up Angle:** 25

**Notes:** #91373 Standard Front Hinge Pin Brace

#91440 Standard Front Caster Blocks

#91404 Standard Steering Blocks

#91362 Standard Top Plate

#91392 Aluminum Steering Set

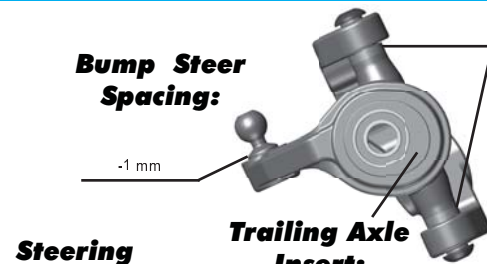

**Axle Height:**

Up

Middle

Down



**Steering Stop Spacing:**

0 mm  2 mm  3 mm  4 mm

**Ball Stud Spacing:** 1 mm

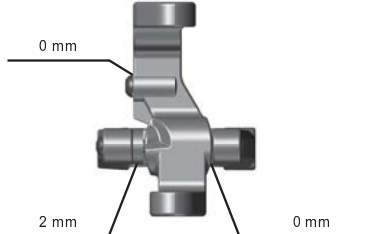

**Caster Block Spacing:**

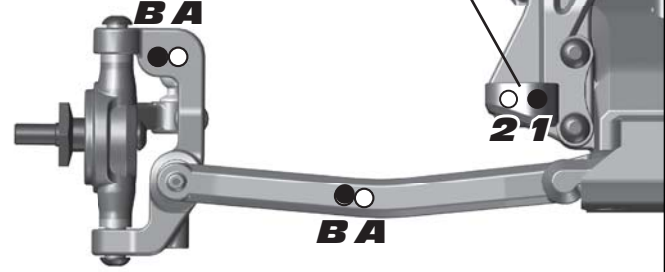

**Rear Suspension:**

**Camber:** -1

**Ride Height:** 24 mm

**Hub Spacing:**

Forward  Middle  Back

**Notes:** #91413 Standard Rear Arms

#91549 Factory Team 0° Aluminum Hubs (Front Row Outside + 3 mm)

#91520 Factory Team Aluminum Camber Link Mount (Low + 3 mm)

#91522 Factory Team Aluminum Arm Mount (C)

#91524 Factory Team Aluminum Arm Mount (D)

#91518 Standard Rear Tower

**Anti Roll Bar:**

None

Black (1.2mm)

Silver (1.3mm)

Gold (1.4mm)

**Rear Hub Link Setting:**

**A** C B A Up  Down

**B** A Up  Down



**Arm Mount:** 2.5 mm

**Inboard Toe:** 3

**Anti-Squat:** 1

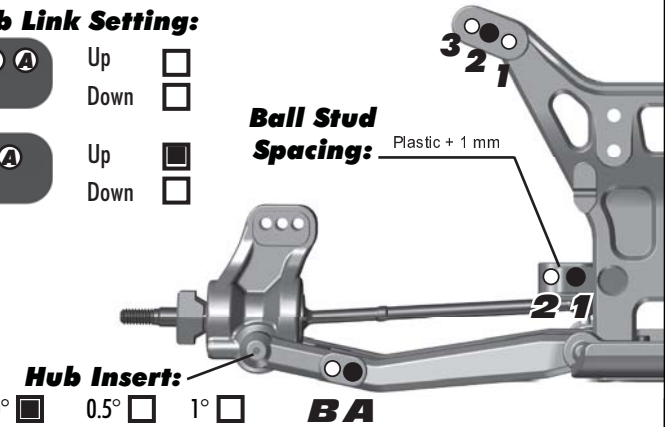

**Electronics:**

**Radio:** Airtronics M12 **Servo:** Sanwa 94671

**EPA Throttle:** 100 % **Brake:** 92 %

**ESC:** Team Orion R10.1

**ESC Settings:** N/A

**Motor:** Team Orion VST2

**Wind:** 7.5 **Timing:** N/A

**Pinion:** 22 **Spur:** 78

**Battery:** Team Orion Carbon 4000mah shorty

**Battery Position:** 2 Thin Pad In The Rear

**Drivetrain:**

**Differential:**

Ball:

Setting: Tight

Gear:

Oil: \_\_\_\_\_

**Slipper Clutch:**

**Type:** Associated

**# of Pads:** 2

**Notes:**

**Shocks:**

	Front	Rear
<b>Piston:</b>	3 x 1.4 Flat	2 x 1.6 Flat
<b>Oil:</b>	32.5 wt	30 wt
<b>Spring:</b>	Gray	White
<b>Limiters:</b>	2	2
<b>Cup Offset:</b>	5mm	5mm
<b>Stroke:</b>	20.0 mm	26.5 mm
<b>Free Length:</b>	N/A	N/A
<b>Notes:</b>	#91493 Factory Team X-Rings	

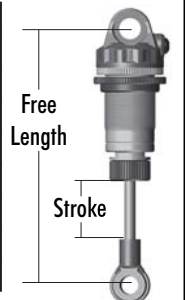

**Track Info:**

**Size:** Small  Medium  Large  Extra Large

**Surfaces:** Dirt  Carpet  Astroturf  Multi Surface

**Traction:** Low  Medium  High  Very High

**Moisture:** Dry  Damp  Wet

**Condition:** Indoor  Outdoor  Dusty  Hard Packed

Bumpy  Grooved  Smooth  Loamy

**Temperature:** Ambient: 70 Track: 70

**Notes:** Dry with dust after a few minutes

**Tires:**

**Tires (F/R):** AKA Typos / AKA Chainlink

**Compound (F/R):** Clay / Clay

**Insert (F/R):** AKA / AKA

**Wheel (F/R):** Team Associated 60mm / Team Associated 60mm

**Notes:**

**Body & Wing:**

**Body:** Team Associated #91538

**Wing:** JConcepts High Clearance 6.5°

**Wing Angle:** 0°  3°  6°

**Notes:** Wing lip cut to 2 lines

**Race Results:**

**Qualify:** 1 **Main:** A

**Finish:** 1 **TQ:**

**Best Lap Time:** 14.9

**Vehicle Comments:**

#91551 Factory Team Bearing Set; #91545 Factory Team Graphite Battery Strap; #91446 & 91447 Factory Team Shock Bushings; #91546 Factory Team Milled Motor Plate; #91450 Factory Team Aluminum Shock Caps;

**Total Vehicle Weight:** 1570g