

Front Suspensions:

Camber: -1

Total Toe: -1/4

Ride Height: 24 mm

Arm Type: #91399 Flat, Hard

Tower Type: #91373 Flat, Standard

Caster Block Insert: 5

Kick-Up Angle: 25

Notes: #91373 Standard Front Hinge Pin Brace

#91440 Standard Front Caster Blocks

#91404 Standard Steering Blocks

#91362 Standard Top Plate

#91392 Aluminum Steering Set

JConcepts Titanium Front Axle

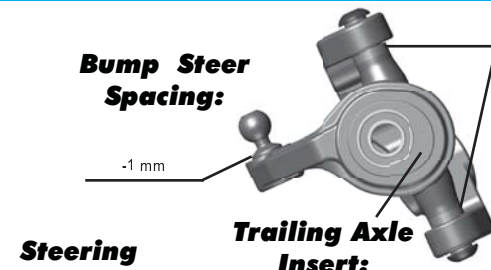

Axle Height:

Up

Middle

Down



Trailing Axle Insert: 2mm 3mm 4mm

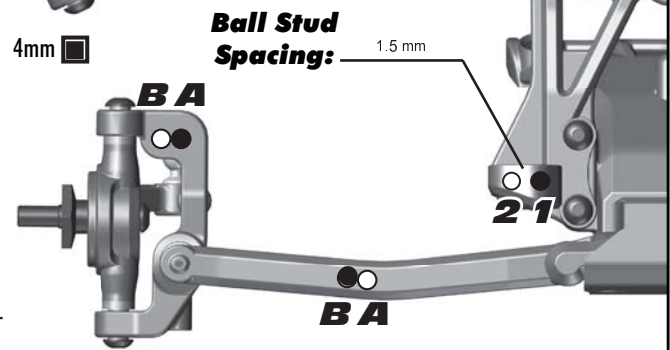
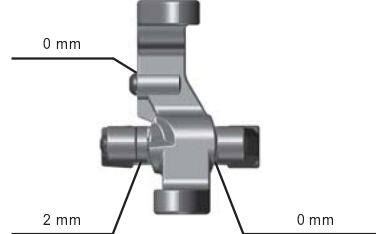

Rear Suspension:

Camber: -1

Ride Height: 24 mm

Hub Spacing: Forward Middle Back

Notes: #91414 Hard Rear Arms

#91549 Factory Team 0° Aluminum Hubs (Front Row Outside + 3 mm)

#91520 Factory Team Aluminum Camber Link Mount (Low + 3 mm)

#91522 Factory Team Aluminum Arm Mount (C)

#91524 Factory Team Aluminum Arm Mount (D)

#91518 Standard Rear Tower

Anti Roll Bar: None Black (1.2mm) Silver (1.3mm) Gold (1.4mm)

Rear Hub Link Setting:

A Up Down

B Up Down



Inboard Toe: 3

Anti-Squat: 1

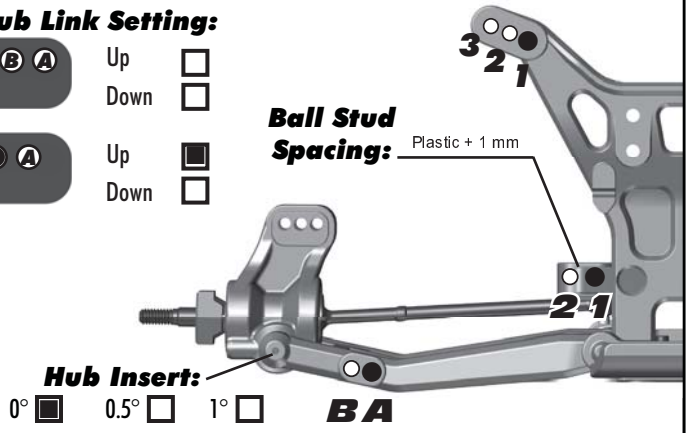

Electronics:

Radio: Airtronics M12 **Servo:** Sanwa 94671

EPA Throttle: 100 % **Brake:** 92 %

ESC: Team Orion R10.1

ESC Settings: Drag Brake=9, Punch=2, Brake Force=62%, Turbo=0

Motor: Team Orion VST2

Wind: 7.5 **Timing:** N/A

Pinion: 23 **Spur:** 81

Battery: Team Orion Carbon 4500 mAh

Battery Position: 2 Thin Pad In The Rear

Drivetrain:

Differential: Ball: Setting: Tight

Gear:

Oil: _____

Slipper Clutch:

Type: Associated

of Pads: 2

Notes: _____

Shocks:

	Front	Rear
Piston:	2 x 1.6 Machined	3 x 1.4 Flat
Oil:	32.5 wt	30 wt
Spring:	AE Gray	AE White
Limiters:	2	2
Cup Offset:	5mm	5mm
Stroke:	21.5 mm	26.5 mm
Free Length:	N/A	N/A
Notes:	#91493 Factory Team X-Rings	

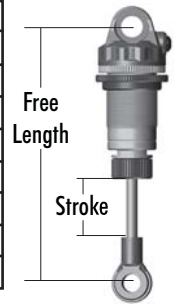

Track Info:

Size: Small Medium Large Extra Large

Surfaces: Dirt Carpet Astroturf Multi Surface

Traction: Low Medium High Very High

Moisture: Dry Damp Wet

Condition: Indoor Outdoor Dusty Hard Packed Bumpy Grooved Smooth Loamy

Temperature: Ambient: 40 Track: 40

Notes: _____

Tires:

Tires (F/R): AKA Chainlink / AKA Chainlink

Compound (F/R): Clay / Clay

Insert (F/R): AKA / AKA

Wheel (F/R): AKA Evo / AKA Small + Bands

Notes: _____

Body & Wing:

Body: Team Associated #91538

Wing: JConcepts High Clearance 6.5°

Wing Angle: 0° 3° 6°

Notes: Wing lip cut to 2 lines; Wing raised 2 shims

Race Results:

Qualify: 2 **Main:** A

Finish: 1 **TQ:**

Best Lap Time: 17.5

Vehicle Comments:

#91551 Factory Team Bearing Set; #91545 Factory Team Graphite Battery Strap; #91446 & 91447 Factory Team Shock Bushings; #91546 Factory Team Milled Motor Plate; #91450 Factory Team Aluminum Shock Caps;

Total Vehicle Weight: 1570g