

**Front Suspensions:**

**Camber:** \_\_\_\_\_ °  
**Total Toe:** \_\_\_\_\_ °  
**Ride Height:** \_\_\_\_\_  
**Arm Type:** \_\_\_\_\_  
**Tower Type:** \_\_\_\_\_  
**Caster Block Insert:** \_\_\_\_\_ °  
**Kick-Up Angle:** \_\_\_\_\_ °

**Notes:** \_\_\_\_\_  
\_\_\_\_\_  
\_\_\_\_\_

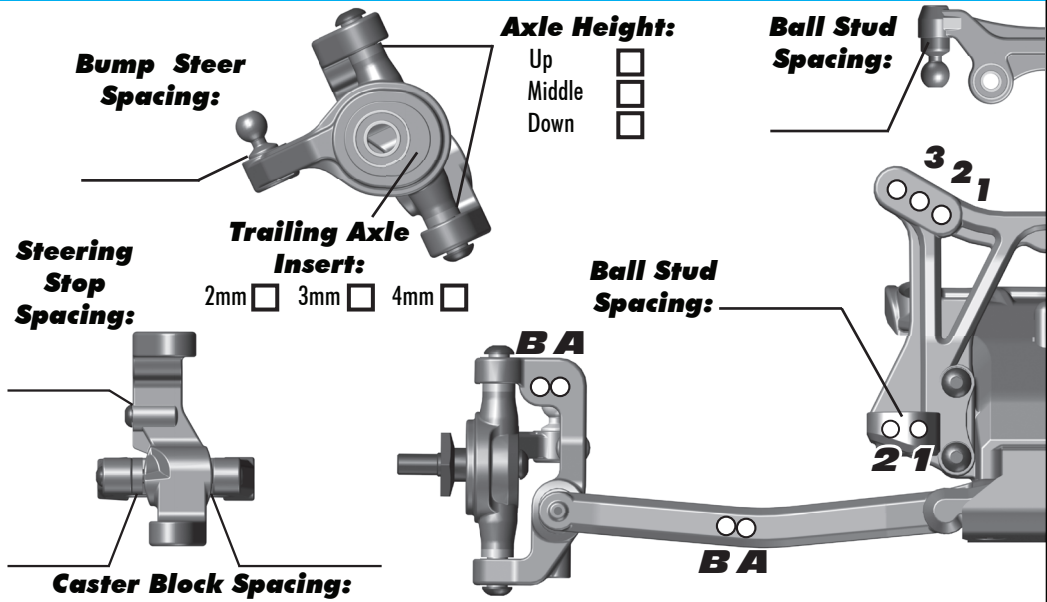

**Rear Suspension:**

**Camber:** \_\_\_\_\_ °  
**Ride Height:** \_\_\_\_\_  
**Hub Spacing:** Forward  Middle  Back

**Notes:** \_\_\_\_\_  
\_\_\_\_\_  
\_\_\_\_\_

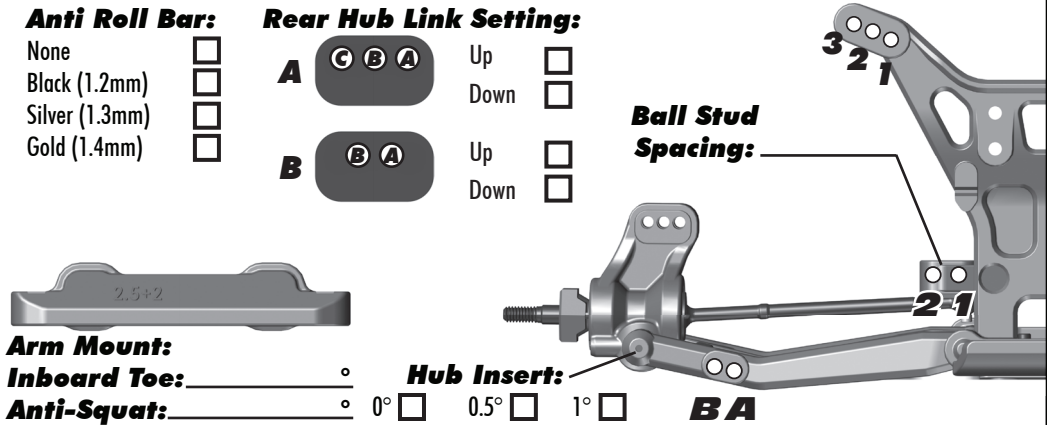

**Electronics:**

**Radio:** \_\_\_\_\_ **Servo:** \_\_\_\_\_  
**EPA: Throttle:** \_\_\_\_\_ % **Brake:** \_\_\_\_\_ %  
**ESC:** \_\_\_\_\_  
**ESC Settings:** \_\_\_\_\_  
**Motor:** \_\_\_\_\_  
**Wind:** \_\_\_\_\_ **Timing:** \_\_\_\_\_  
**Pinion:** \_\_\_\_\_ **Spur:** \_\_\_\_\_  
**Battery:** \_\_\_\_\_  
**Battery Position:** \_\_\_\_\_

**Drivetrain:**

**Differential:** Ball:  Setting: \_\_\_\_\_  
Gear:  Oil: \_\_\_\_\_

**Slipper Clutch:**

**Type:** \_\_\_\_\_  
**# of Pads:** \_\_\_\_\_  
**Notes:** \_\_\_\_\_

**Shocks:**

|                     | Front | Rear |
|---------------------|-------|------|
| <b>Piston:</b>      |       |      |
| <b>Oil:</b>         |       |      |
| <b>Spring:</b>      |       |      |
| <b>Limiters:</b>    |       |      |
| <b>Cup Offset:</b>  |       |      |
| <b>Stroke:</b>      |       |      |
| <b>Free Length:</b> |       |      |
| <b>Notes:</b>       |       |      |

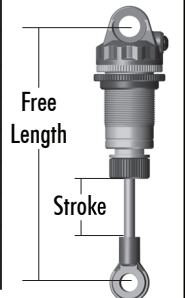

**Track Info:**

**Size:** Small  Medium  Large  Extra Large   
**Surfaces:** Dirt  Carpet  Astroturf  Multi Surface   
**Traction:** Low  Medium  High  Very High   
**Moisture:** Dry  Damp  Wet   
**Condition:** Indoor  Outdoor  Dusty  Hard Packed   
Bumpy  Grooved  Smooth  Loamy

**Temperature:** Ambient: \_\_\_\_\_ Track: \_\_\_\_\_

**Notes:** \_\_\_\_\_  
\_\_\_\_\_

**Tires:**

**Tires (F/R):** \_\_\_\_\_ / \_\_\_\_\_  
**Compound (F/R):** \_\_\_\_\_ / \_\_\_\_\_  
**Insert (F/R):** \_\_\_\_\_ / \_\_\_\_\_  
**Wheel (F/R):** \_\_\_\_\_ / \_\_\_\_\_  
**Notes:** \_\_\_\_\_

**Body & Wing:**

**Body:** \_\_\_\_\_  
**Wing:** \_\_\_\_\_  
**Wing Angle:** 0°  3°  6°  \_\_\_\_\_  
**Notes:** \_\_\_\_\_

**Race Results:**

**Qualify:** \_\_\_\_\_ **Main:** \_\_\_\_\_  
**Finish:** \_\_\_\_\_ **TQ:**  \_\_\_\_\_  
**Best Lap Time:** \_\_\_\_\_

**Vehicle Comments:**

\_\_\_\_\_  
\_\_\_\_\_  
\_\_\_\_\_ **Total Vehicle Weight:** \_\_\_\_\_