

**Front Suspension:**

**Camber:** \_\_\_\_\_ °  
**Total Toe:** \_\_\_\_\_ °  
**Ride Height:** \_\_\_\_\_  
**Arm Type:** \_\_\_\_\_  
**Tower Type:** \_\_\_\_\_  
**Caster Block Insert:** \_\_\_\_\_ °  
**Kick-Up Angle:** \_\_\_\_\_ °

**Notes:**

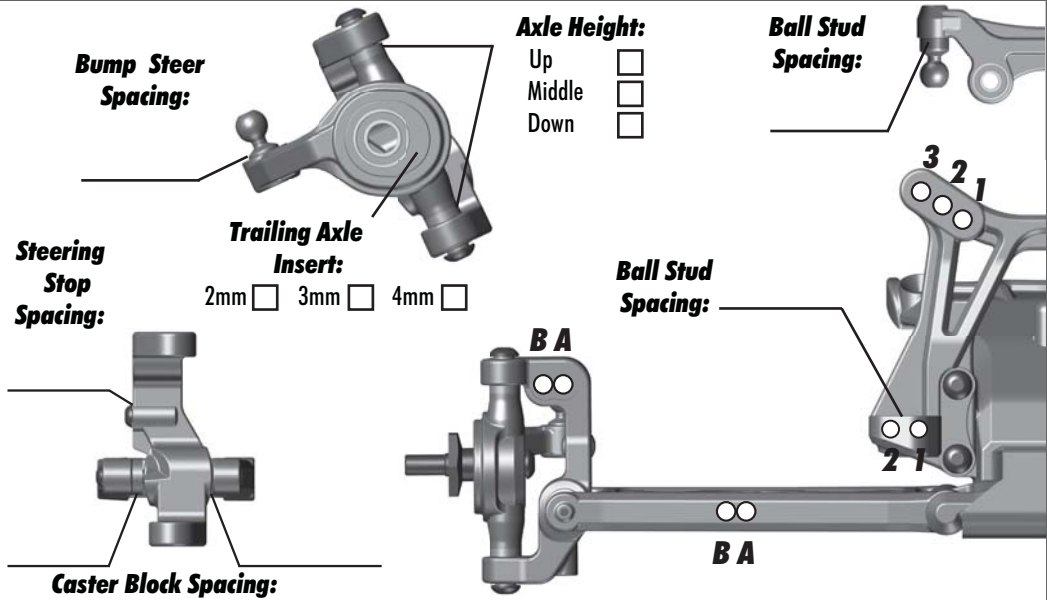

**Rear Suspension:**

**Camber:** \_\_\_\_\_ °  
**Ride Height:** \_\_\_\_\_  
**Hub Spacing:**  
 Forward  Middle  Back

**Notes:**

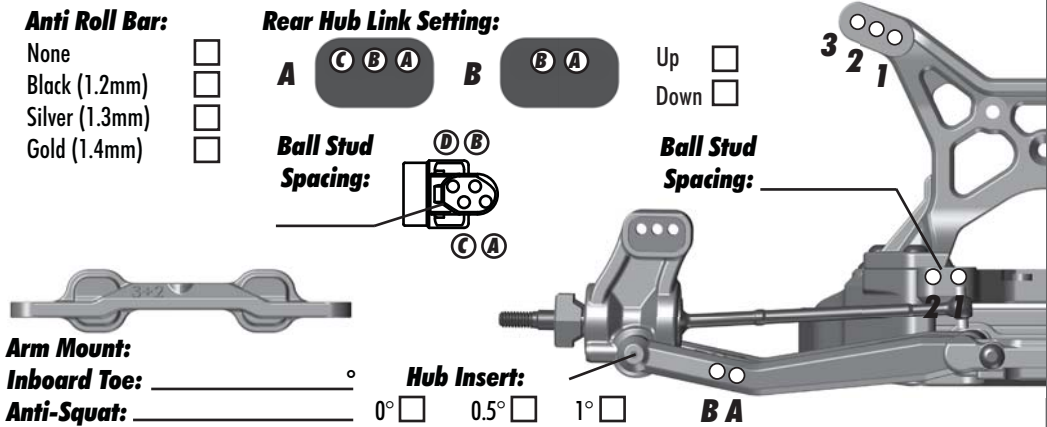

**Electronics:**

**Radio:** \_\_\_\_\_ **Servo:** \_\_\_\_\_  
**EPA: Throttle:** \_\_\_\_\_ % **Brake:** \_\_\_\_\_ %  
**ESC:** \_\_\_\_\_  
**ESC Settings:** \_\_\_\_\_  
**Motor:** \_\_\_\_\_  
**Wind:** \_\_\_\_\_ **Timing:** \_\_\_\_\_  
**Pinion:** \_\_\_\_\_ **Spur:** \_\_\_\_\_  
**Battery:** \_\_\_\_\_  
**Battery Position:** \_\_\_\_\_

**Drivetrain:**

**Differential:**  
 Ball:   
 Setting: \_\_\_\_\_  
 Gear:   
 Oil: \_\_\_\_\_

**Slipper Clutch:**  
**Type:** \_\_\_\_\_  
**# of Pads:** \_\_\_\_\_  
**Notes:** \_\_\_\_\_

**Shocks:**

	Front	Rear
<b>Piston:</b>		
<b>Oil:</b>		
<b>Spring:</b>		
<b>Limiters:</b>		
<b>Cup Offset:</b>		
<b>Stroke:</b>		
<b>Free Length:</b>		
<b>Notes:</b>		

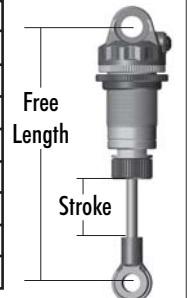

**Track Info:**

**Size:** Small  Medium  Large  Extra Large   
**Surfaces:** Dirt  Carpet  AstroTurf  Multi Surface   
**Traction:** Low  Medium  High  Very High   
**Moisture:** Dry  Damp  Wet   
**Condition:** Indoor  Outdoor  Dusty  Hard Packed   
 Bumpy  Grooved  Smooth  Loamy

**Temperature:** Ambient: \_\_\_\_\_ Track: \_\_\_\_\_  
**Notes:**

**Tires:**

\_\_\_\_\_ :F - Tires - R:  
 \_\_\_\_\_ :F - Compound - R:  
 \_\_\_\_\_ :F - Insert - R:  
 \_\_\_\_\_ :F - Wheel - R:  
 \_\_\_\_\_ :F - Notes - R:

**Body & Wing:**

**Body:** \_\_\_\_\_  
**Wing:** \_\_\_\_\_  
**Wing Angle:** 0°  3°  6°   
**Notes:** \_\_\_\_\_

**Race Results:**

**Quality:** \_\_\_\_\_ **Main:** \_\_\_\_\_  
**Finish:** \_\_\_\_\_ **TQ:**   
**Best Lap Time:** \_\_\_\_\_

**Vehicle Comments:**

**Total Vehicle Weight:** \_\_\_\_\_