

Front Suspension:

Camber: _____ °
Total Toe: _____ °
Ride Height: _____
Arm Type: _____
Tower Type: _____
Caster Block Insert: _____ °
Kick-Up Angle: _____ °

Notes: _____

Bump Steer Spacing:

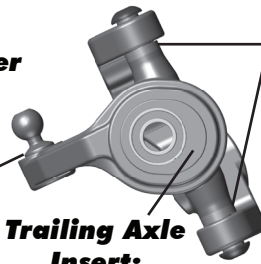

Trailing Axle Insert:

2mm 3mm 4mm

Steering Stop Spacing:

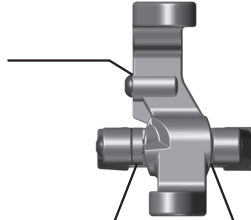

Caster Block Spacing:

Axle Height:

Up
Middle
Down

Ball Stud Spacing:



Ball Stud Spacing:

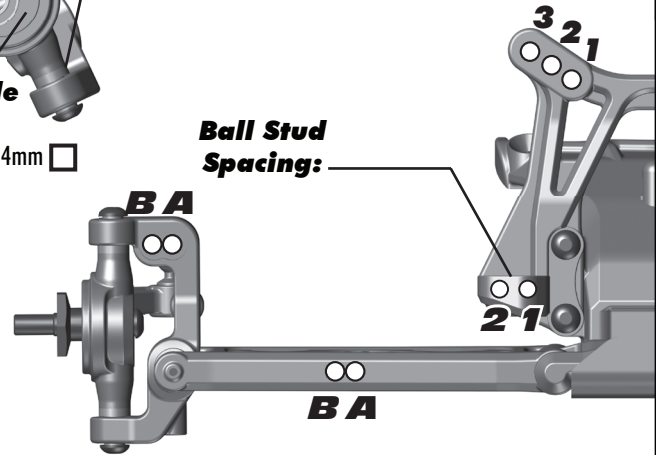

Rear Suspension:

Camber: _____ °
Ride Height: _____
Hub Spacing:

Forward Middle Back

Notes: _____

Anti Roll Bar:

None
Black (1.2mm)
Silver (1.3mm)
Gold (1.4mm)

Rear Hub Link Setting:

A C B A Up
Down
B B A Up
Down

Ball Stud Spacing:



Arm Mount:

Inboard Toe: _____ °

Anti-Squat: _____ °

Hub Insert:

0° 0.5° 1°

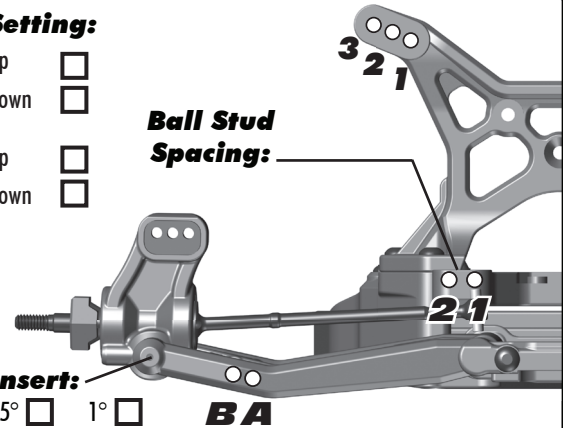

Electronics:

Radio: _____ **Servo:** _____
EPA: Throttle: _____ % **Brake:** _____ %
ESC: _____
ESC Settings: _____
Motor: _____
Wind: _____ **Timing:** _____
Pinion: _____ **Spur:** _____
Battery: _____
Battery Position: _____

Drivetrain:

Differential:

Ball:
Setting: _____
Gear:
Oil: _____

Slipper Clutch:

Type: _____
of Pads: _____
Notes: _____

Shocks:

	Front	Rear
Piston:		
Oil:		
Spring:		
Limiters:		
Cup Offset:		
Stroke:		
Free Length:		
Notes:		

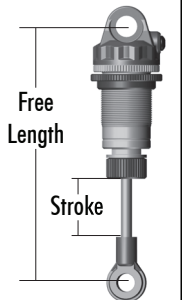

Track Info:

Size: Small Medium Large Extra Large
Surfaces: Dirt Carpet Astroturf Multi Surface
Traction: Low Medium High Very High
Moisture: Dry Damp Wet
Condition: Indoor Outdoor Dusty Hard Packed
Bumpy Grooved Smooth Loamy

Temperature: Ambient: _____ Track: _____

Notes: _____

Tires:

Tires (F/R): _____ / _____
Compound (F/R): _____ / _____
Insert (F/R): _____ / _____
Wheel (F/R): _____ / _____
Notes: _____

Body & Wing:

Body: _____
Wing: _____
Wing Angle: 0° 3° 6° _____
Notes: _____

Race Results:

Qualify: _____ **Main:** _____
Finish: _____ **TQ:**
Best Lap Time: _____

Vehicle Comments:

Total Vehicle Weight: _____