

Front Suspension:

Camber: -2
Total Toe: 0
Ride Height: 19
Arm Type: flat/standard
Tower Type: flat/standard
Caster Block Insert: 0
Kick-Up Angle: 30

Notes: aluminium hinge pin place

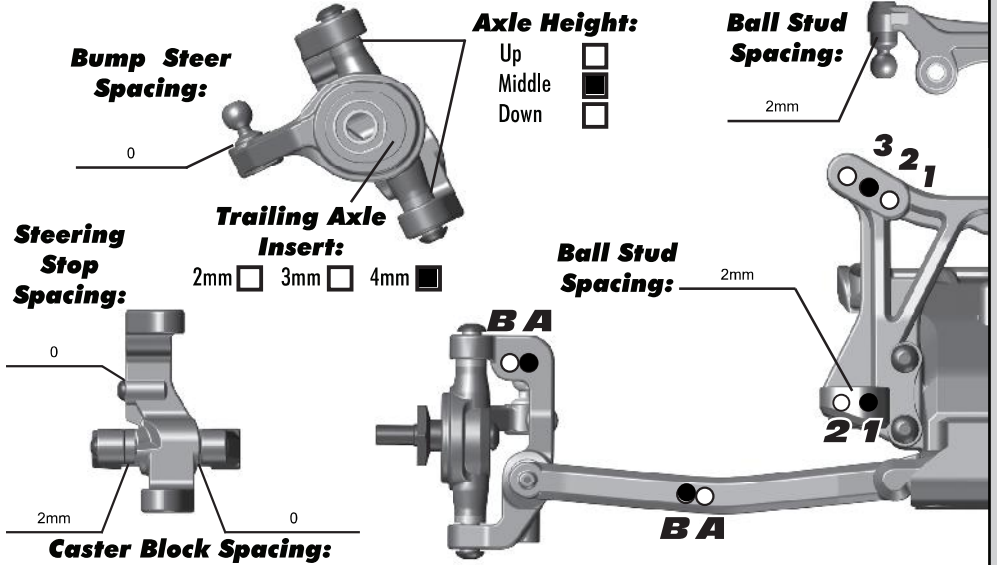

Rear Suspension:

Camber: -2
Ride Height: 19
Hub Spacing: Forward Middle Back

Notes: schelle aluminium ballstud mount
3 gear transmission for B5M

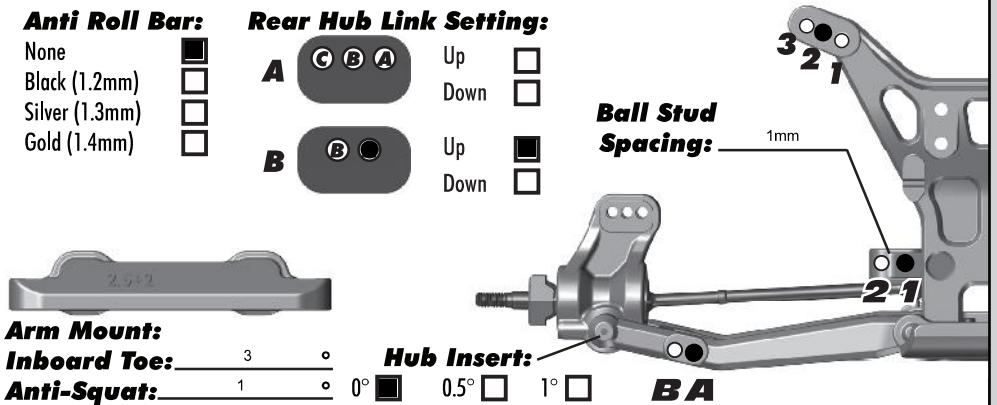

Electronics:

Radio: M12 **Servo:** SRG-BLS
EPA: Throttle: 100% **Brake:** 90%
ESC: RP
ESC Settings: punch rate 2 / max brake 90%
Motor: RP
Wind: 7.5 **Timing:** 30
Pinion: **Spur:** 87
Battery: yokomo 4200 shorty
Battery Position: longwise

Drivetrains:

Differential: Ball: Setting: _____ Gear: Oil: 2000

Slipper Clutch:

Type: AE
of Pads: 2
Notes: tight

Shocks:

	Front	Rear
Piston:	2x1.6 flat	2x1.7 flat
Oil:	35	30
Spring:	green	green
Limiters:	2mm	2mm
Cup Offset:	4mm	2mm
Stroke:	20.5	26.75
Free Length:		
Notes:	factory team X-ring	

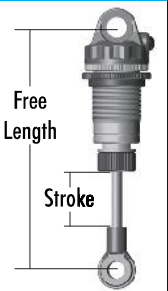

Track Info:

Size: Small Medium Large Extra Large
Surfaces: Dirt Carpet Astro turf Multi Surface
Traction: Low Medium High Very High
Moisture: Dry Damp Wet
Condition: Indoor Outdoor Dusty Hard Packed Bumpy Grooved Smooth Loamy

Temperature: Ambient: _____ Track: _____
Notes: _____

Tires:

Tires (F/R): cut stugger / minipin
Compound (F/R): yellow / yellow
Insert (F/R): none / foam type
Wheel (F/R): yokomo (cut a inside) / yokomo
Notes: _____

Body & Wing:

Body: JC finisher
Wing: JC Highclearance 6.5
Wing Angle: 0° 3° 6°
Notes: _____

Race Results:

Qualify: 4 **Main:** A
Finish: 4 **TQ:**
Best Lap Time: _____

Vehicle Comments:

Total Vehicle Weight: _____