

### Front Suspensions:

Reset Forms

**Camber:** -2   
**Total Toe:** 0   
**Ride Height:** 18 mm  
**Arm Type:** #91526, Gullwing Standard  
**Tower Type:** #91516, Gullwing Standard  
**Caster Block Insert:** 0   
**Kick-Up Angle:** 25   
**Wheel Hex:** Kit

**Notes:**  
 \_\_\_\_\_  
 \_\_\_\_\_  
 \_\_\_\_\_

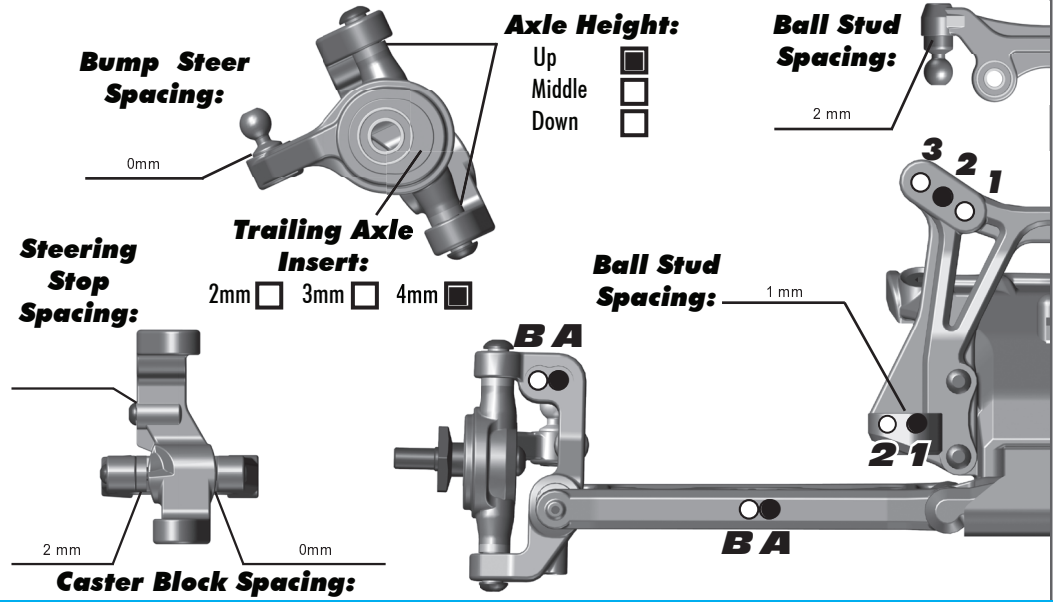

### Rear Suspension:

**Camber:** -2   
**Ride Height:** 18 mm  
**Wheel Hex:** #91610, Clamping Hex 7 mm  
**Hub Spacing:** Forward  Middle  Back

**Notes:** Green Anti Roll Bar  
 \_\_\_\_\_  
 \_\_\_\_\_

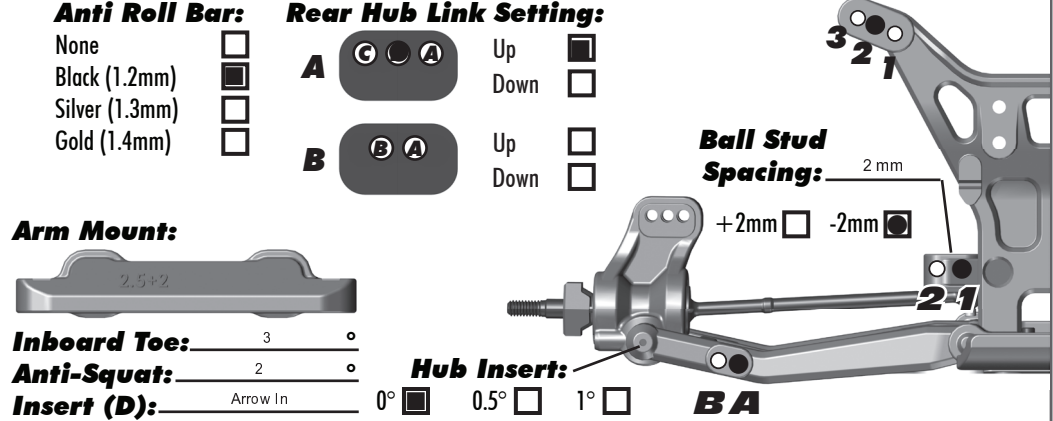

### Electronics:

**Radio:** Sanwa M12 **Servo:** Reedy 1206  
**EPA: Throttle:** 100 % **Brake:** 77 %  
**ESC:** Reedy  
**ESC Settings:** N/A  
**Motor:** Reedy Sonic Mach2  
**Wind:** 8.0 **Timing:** 20  
**Pinion:** 25 **Spur:** 78  
**Battery:** Reedy 4100 mAh #602  
**Battery Position:** Forward

### Drivetrain:

**Differential:**  
**3 Gear:**  **4 Gear:**   
**Ball Diff:**  **Gear Diff:**   
**Notes:** Standard

### Slipper Clutch:

**Type:** Associated  
**# of Pads:** 2  
**Notes:** \_\_\_\_\_

### Shocks:

	Front	Rear
<b>Piston:</b>	2 x 1.6 Flat	2 x 1.6 Flat
<b>Oil:</b>	32.5 wt	30 wt
<b>Spring:</b>	TLR Green	TLR Pink
<b>Limiters:</b>	2 mm	2 mm
<b>Cup Offset:</b>	5 mm	0 mm
<b>Stroke:</b>	20 mm	26.5 mm
<b>Free Length:</b>	N/A	N/A
<b>Notes:</b>		

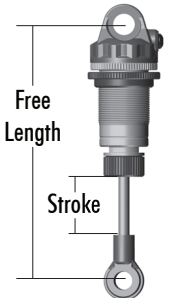

### Track Info:

**Size:** Small  Medium  Large  Extra Large   
**Surfaces:** Dirt  Carpet  Astroturf  Multi Surface   
**Traction:** Low  Medium  High  Very High   
**Moisture:** Dry  Damp  Wet   
**Condition:** Indoor  Outdoor  Dusty  Hard Packed   
 Bumpy  Grooved  Smooth  Loamy

**Temperature:** Ambient: \_\_\_\_\_ Track: \_\_\_\_\_  
**Notes:** \_\_\_\_\_

### Tires:

**Tires (F/R):** Schumacher Cut Stagger Low Profile / Schumacher Mini Pin 2  
**Compound (F/R):** Yellow / Yellow  
**Insert (F/R):** None / Schumacher Medium  
**Wheel (F/R):** Team Associated / Team Associated  
**Notes:** \_\_\_\_\_

### Body, Wing & Chassis:

**Body:** JConcepts Silencer  
**Wing:** JConcepts Hi-Clearance 6.5" (Zero Wing Lip)  
**Wing Angle:** 0°  3°  6°   
**Chassis:** #91510 - B5M  #91511 - B5M Lite

### Race Results:

**Qualify:** 2nd **Main:** A  
**Finish:** 1st **TQ:**   
**Best Lap Time:** \_\_\_\_\_

### Vehicle Comments:

50g behind battery  
 \_\_\_\_\_  
**Total Vehicle Weight:** \_\_\_\_\_