

**Driver:** \_\_\_\_\_

**Date:** \_\_\_\_\_

**Track:** \_\_\_\_\_

**Event:** \_\_\_\_\_

**Front Suspension:**

- Camber:** \_\_\_\_\_ °
- Total Toe:** \_\_\_\_\_ °
- Ride Height:** \_\_\_\_\_
- Arm Type:** \_\_\_\_\_
- Tower Type:** \_\_\_\_\_
- Caster Block Insert:** \_\_\_\_\_ °
- Kick-Up Angle:** \_\_\_\_\_ °

**Notes:**

**Bump Steer Spacing:**



**Trailing Axle Insert:**  
2mm  3mm  4mm

**Steering Stop Spacing:**

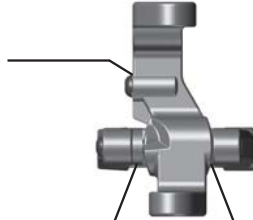

**Caster Block Spacing:**

**Axle Height:**

- Up
- Middle
- Down

**Ball Stud Spacing:**



**Ball Stud Spacing:**

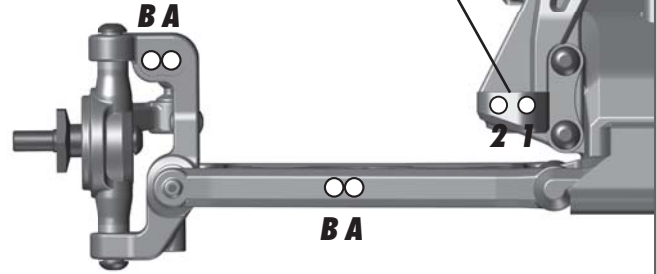

**Rear Suspension:**

- Camber:** \_\_\_\_\_ °
- Ride Height:** \_\_\_\_\_
- Hub Spacing:**  
Forward  Middle  Back

**Notes:**

**Anti Roll Bar:**

- None
- Black (1.2mm)
- Silver (1.3mm)
- Gold (1.4mm)

**Rear Hub Link Setting:**



- Up
- Down

**Ball Stud Spacing:**

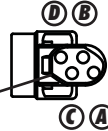

**Ball Stud Spacing:**

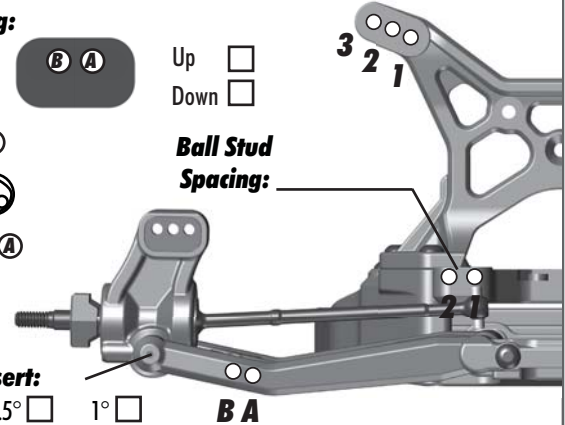

**Arm Mount:**

**Inboard Toe:** \_\_\_\_\_ °

**Anti-Squat:** \_\_\_\_\_ °

**Hub Insert:**

- 0°  0.5°  1°

**Electronics:**

- Radio:** \_\_\_\_\_ **Servo:** \_\_\_\_\_
- EPA: Throttle:** \_\_\_\_\_ % **Brake:** \_\_\_\_\_ %
- ESC:** \_\_\_\_\_
- ESC Settings:** \_\_\_\_\_
- Motor:** \_\_\_\_\_
- Wind:** \_\_\_\_\_ **Timing:** \_\_\_\_\_
- Pinion:** \_\_\_\_\_ **Spur:** \_\_\_\_\_
- Battery:** \_\_\_\_\_
- Battery Position:** \_\_\_\_\_

**Drivetrain:**

- Differential:**  
Ball:
- Setting: \_\_\_\_\_
- Gear:
- Oil: \_\_\_\_\_
- Slipper Clutch:**
- Type:** \_\_\_\_\_
- # of Pads:** \_\_\_\_\_
- Notes:**

**Shocks:**

	Front	Rear
<b>Piston:</b>		
<b>Oil:</b>		
<b>Spring:</b>		
<b>Limiters:</b>		
<b>Cup Offset:</b>		
<b>Stroke:</b>		
<b>Free Length:</b>		
<b>Notes:</b>		



**Track Info:**

- Size:** Small  Medium  Large  Extra Large
- Surfaces:** Dirt  Carpet  Astroturf  Multi Surface
- Traction:** Low  Medium  High  Very High
- Moisture:** Dry  Damp  Wet
- Condition:** Indoor  Outdoor  Dusty  Hard Packed
- Bumpy  Grooved  Smooth  Loamy

**Temperature:** Ambient: \_\_\_\_\_ Track: \_\_\_\_\_

**Notes:**

**Tires:**

- \_\_\_\_\_ **:F - Tires - R:** \_\_\_\_\_
- \_\_\_\_\_ **:F - Compound - R:** \_\_\_\_\_
- \_\_\_\_\_ **:F - Insert - R:** \_\_\_\_\_
- \_\_\_\_\_ **:F - Wheel - R:** \_\_\_\_\_
- \_\_\_\_\_ **:F - Notes - R:** \_\_\_\_\_

**Body & Wing:**

- Body:** \_\_\_\_\_
- Wing:** \_\_\_\_\_
- Wing Angle:** 0°  3°  6°
- Notes:**

**Race Results:**

- Quality:** \_\_\_\_\_ **Main:** \_\_\_\_\_
- Finish:** \_\_\_\_\_ **TQ:**
- Best Lap Time:** \_\_\_\_\_

**Vehicle Comments:**

**Total Vehicle Weight:** \_\_\_\_\_