

**Front Suspension:**

Camber: \_\_\_\_\_  
Total Toe: \_\_\_\_\_  
Ride Height: \_\_\_\_\_  
Arm Type: \_\_\_\_\_  
Tower Type: \_\_\_\_\_  
Caster Block Insert: \_\_\_\_\_  
Kick-Up Angle: \_\_\_\_\_  
Wheel Hex: \_\_\_\_\_

Notes: \_\_\_\_\_

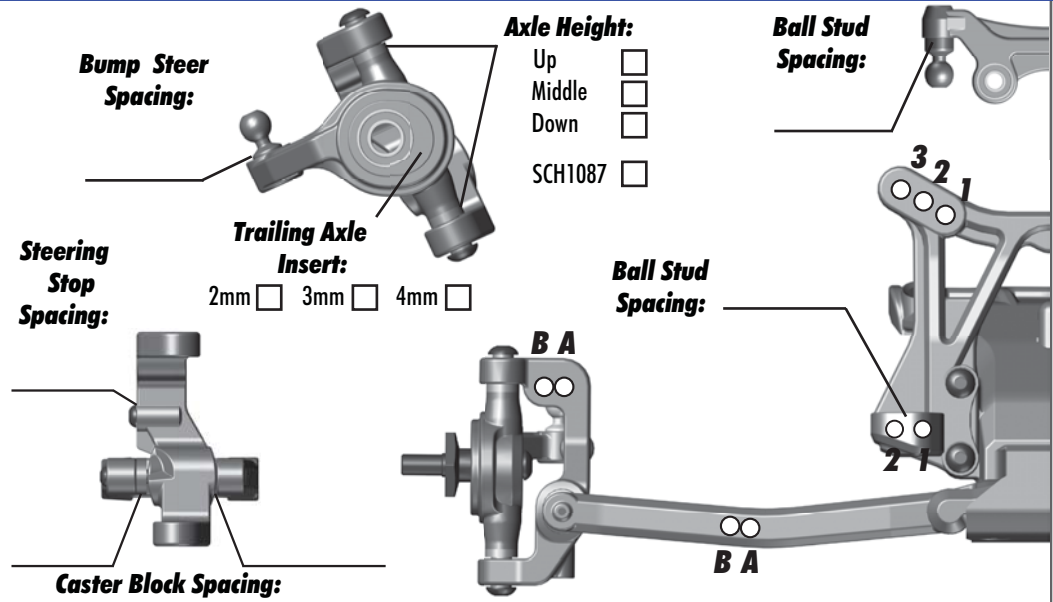

**Rear Suspension:**

Camber: \_\_\_\_\_  
Ride Height: \_\_\_\_\_  
Wheel Hex: \_\_\_\_\_  
Hub Spacing:  
Forward  Middle  Back

Notes: \_\_\_\_\_

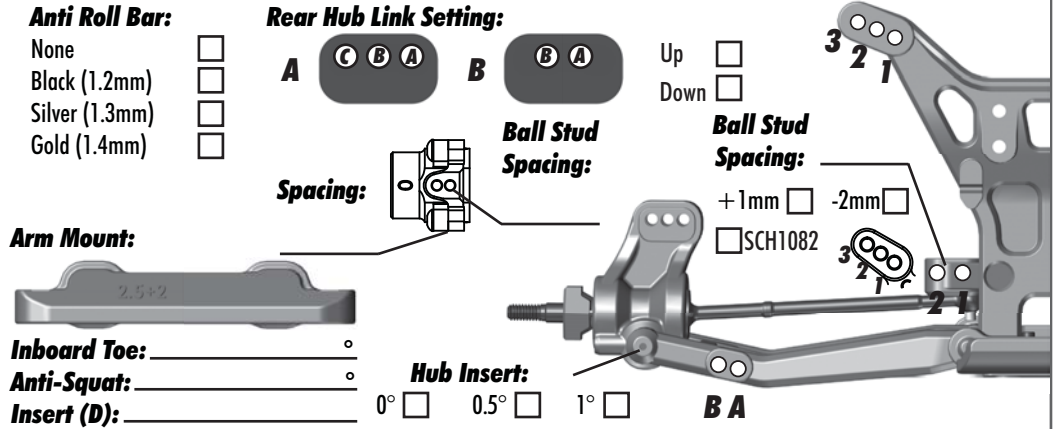

**Electronics:**

Radio: \_\_\_\_\_ Servo: \_\_\_\_\_  
EPA: Throttle: \_\_\_\_\_ % Brake: \_\_\_\_\_ %  
ESC: \_\_\_\_\_  
ESC Settings: \_\_\_\_\_  
Motor: \_\_\_\_\_  
Wind: \_\_\_\_\_ Timing: \_\_\_\_\_  
Pinion: \_\_\_\_\_ Spur: \_\_\_\_\_  
Battery: \_\_\_\_\_  
Battery Position: \_\_\_\_\_

**Drivetrain:**

**Differential:** Ball  Gear   
**Gearbox:** 3 Gears  4 Gears   
Notes: \_\_\_\_\_

**Slipper Clutch:**

Type: \_\_\_\_\_  
# of Pads: \_\_\_\_\_  
Notes: \_\_\_\_\_

**Shocks:**

	Front	Rear
<b>Piston:</b>		
<b>Oil:</b>		
<b>Spring:</b>		
<b>Limiters:</b>		
<b>Cup Offset:</b>		
<b>Stroke:</b>		
<b>Free Length:</b>		
<b>Notes:</b>		

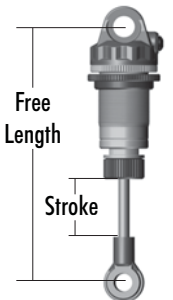

**Track Info:**

**Size:** Small  Medium  Large  Extra Large   
**Surfaces:** Dirt  Carpet  Astroturf  Multi Surface   
**Traction:** Low  Medium  High  Very High   
**Moisture:** Dry  Damp  Wet   
**Condition:** Indoor  Outdoor  Dusty  Hard Packed   
Bumpy  Grooved  Smooth  Loamy

Temperature: Ambient: \_\_\_\_\_ Track: \_\_\_\_\_  
Notes: \_\_\_\_\_

**Tires:**

\_\_\_\_\_:F - Tires - R: \_\_\_\_\_  
\_\_\_\_\_:F - Compound - R: \_\_\_\_\_  
\_\_\_\_\_:F - Insert - R: \_\_\_\_\_  
\_\_\_\_\_:F - Wheel - R: \_\_\_\_\_  
\_\_\_\_\_:F - Notes - R: \_\_\_\_\_

**Body & Wing:**

Body: \_\_\_\_\_  
Wing: \_\_\_\_\_  
Wing Angle: 0°  3°  6°   
Notes: \_\_\_\_\_

**Race Results:**

Quality: \_\_\_\_\_ Main: \_\_\_\_\_  
Finish: \_\_\_\_\_ TQ:   
Best Lap Time: \_\_\_\_\_

**Vehicle Comments:**

Total Vehicle Weight: \_\_\_\_\_