

Driver: \_\_\_\_\_ Date: \_\_\_\_\_

Track: \_\_\_\_\_ Event: \_\_\_\_\_

## Front Suspension:

Camber: \_\_\_\_\_  
 Total Toe: \_\_\_\_\_  
 Ride Height: \_\_\_\_\_  
 Arm Type: \_\_\_\_\_  
 Tower Type: \_\_\_\_\_  
 Caster Block Insert: \_\_\_\_\_  
 Kick-Up Angle: \_\_\_\_\_  
 Wheel Hex: \_\_\_\_\_

Notes: \_\_\_\_\_

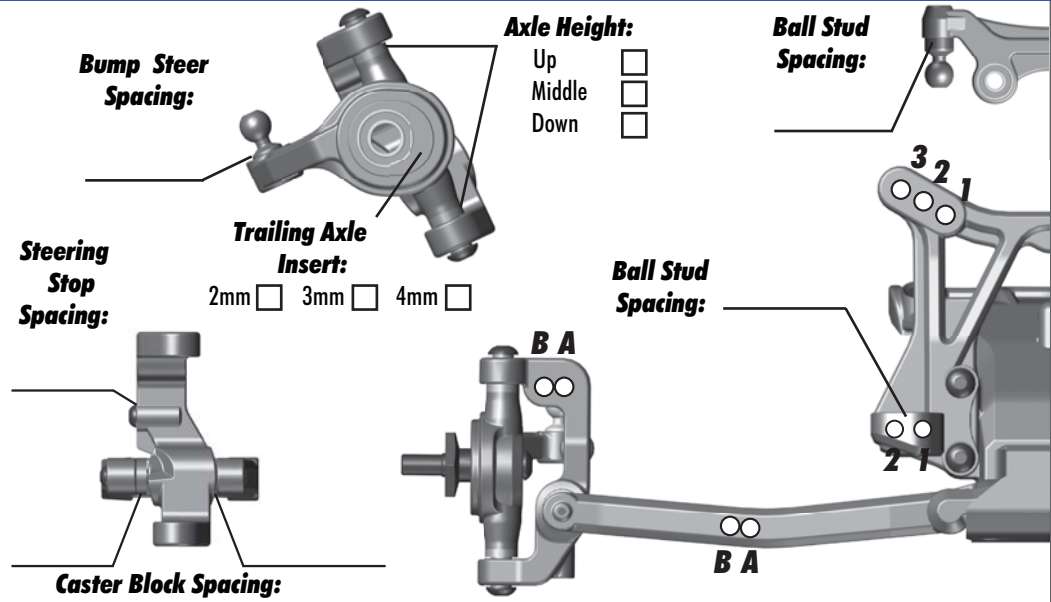

## Rear Suspension:

Camber: \_\_\_\_\_  
 Ride Height: \_\_\_\_\_  
 Wheel Hex: \_\_\_\_\_  
 Hub Spacing: \_\_\_\_\_

Forward  Middle  Back

Notes: \_\_\_\_\_

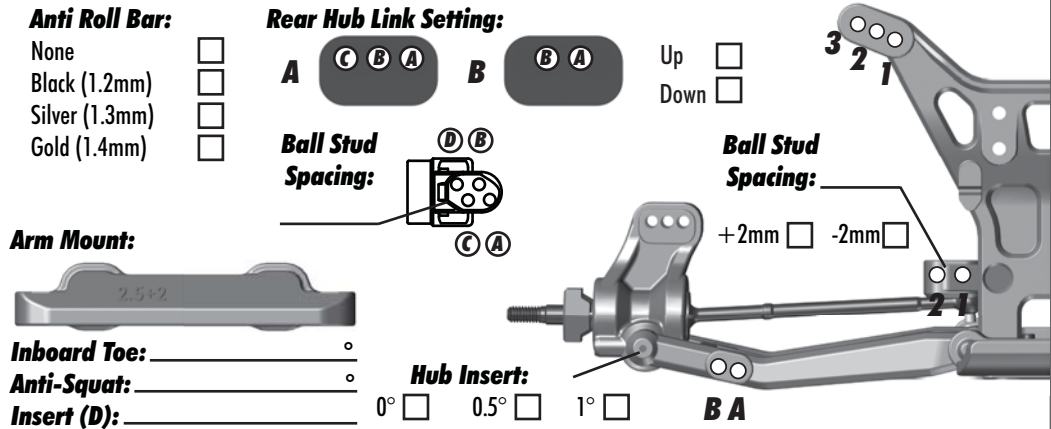

## Electronics:

Radio: \_\_\_\_\_ Servo: \_\_\_\_\_  
 EPA: Throttle: \_\_\_\_\_ % Brake: \_\_\_\_\_ %  
 ESC: \_\_\_\_\_  
 ESC Settings: \_\_\_\_\_  
 Motor: \_\_\_\_\_  
 Wind: \_\_\_\_\_ Timing: \_\_\_\_\_  
 Pinion: \_\_\_\_\_ Spur: \_\_\_\_\_  
 Battery: \_\_\_\_\_  
 Battery Position: \_\_\_\_\_

## Drivetrain:

**Differential:** Ball  Gear   
**Gearbox:** 3 Gears  4 Gears

Notes: \_\_\_\_\_

## Slipper Clutch:

Type: \_\_\_\_\_  
 # of Pads: \_\_\_\_\_  
 Notes: \_\_\_\_\_

## Shocks:

	Front	Rear
<b>Piston:</b>		
<b>Oil:</b>		
<b>Spring:</b>		
<b>Limiters:</b>		
<b>Cup Offset:</b>		
<b>Stroke:</b>		
<b>Free Length:</b>		
<b>Notes:</b>		

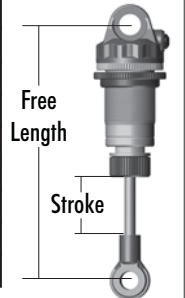

## Track Info:

**Size:** Small  Medium  Large  Extra Large   
**Surfaces:** Dirt  Carpet  Astroturf  Multi Surface   
**Traction:** Low  Medium  High  Very High   
**Moisture:** Dry  Damp  Wet   
**Condition:** Indoor  Outdoor  Dusty  Hard Packed   
 Bumpy  Grooved  Smooth  Loamy

Temperature: Ambient: \_\_\_\_\_ Track: \_\_\_\_\_

Notes: \_\_\_\_\_

## Tires:

\_\_\_\_\_ :F - Tires - R:  
 \_\_\_\_\_ :F - Compound - R:  
 \_\_\_\_\_ :F - Insert - R:  
 \_\_\_\_\_ :F - Wheel - R:  
 \_\_\_\_\_ :F - Notes - R:

## Body & Wing:

Body: \_\_\_\_\_  
 Wing: \_\_\_\_\_  
 Wing Angle: 0°  3°  6°   
 Notes: \_\_\_\_\_

## Race Results:

Quality: \_\_\_\_\_ Main: \_\_\_\_\_  
 Finish: \_\_\_\_\_ TQ:   
 Best Lap Time: \_\_\_\_\_

## Vehicle Comments:

Total Vehicle Weight: \_\_\_\_\_